

## EB 3992 EN

Translation of original instructions

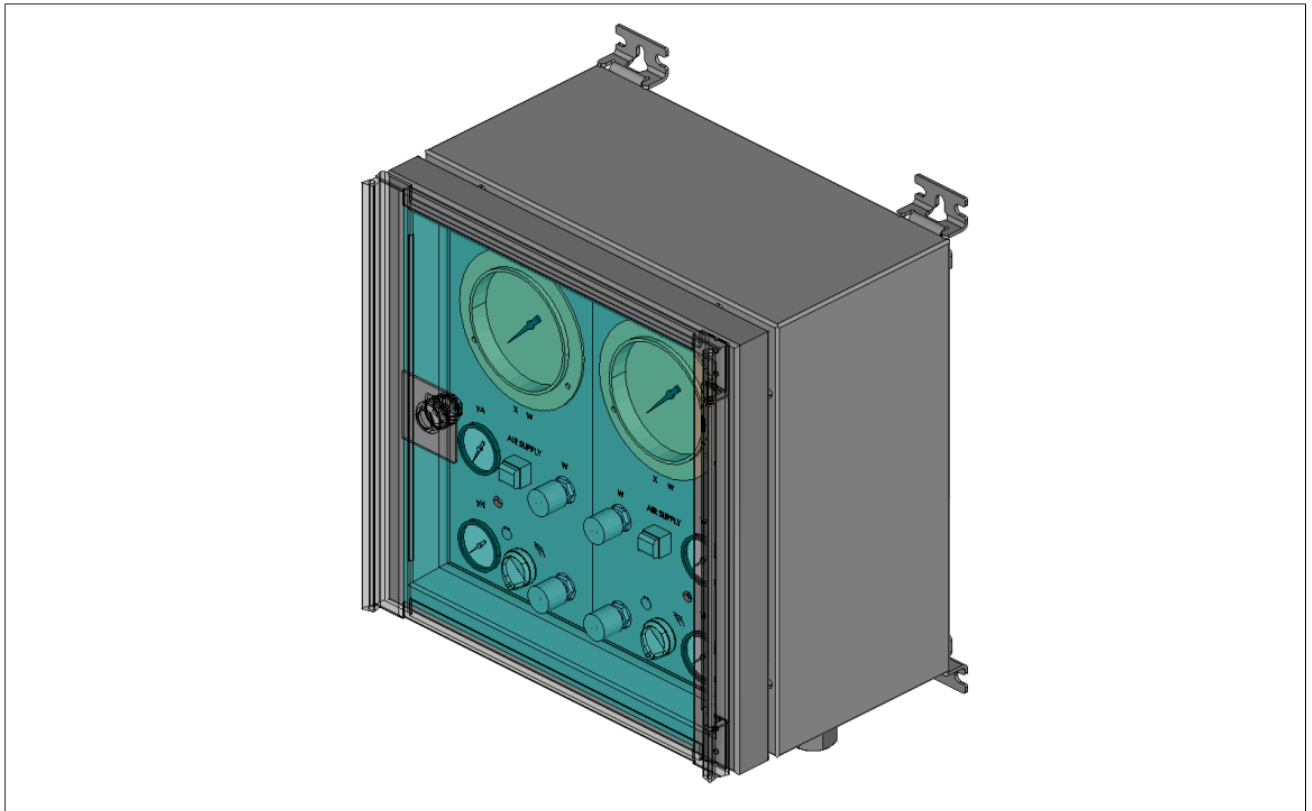

## Type 7311 Air Control System

Systems and Modules

### Note on these mounting and operating instructions

These mounting and operating instructions (EB) assist you in mounting and operating the device safely. The instructions are binding for handling SAMSON devices. The images shown in this document are for illustration purposes only. The actual product may vary.

- ⇒ For the safe and proper use of these instructions, read them carefully and keep them for later reference.
- ⇒ If you have any additional questions not related to the contents of these instructions, contact SAMSON's After-sales Service Department (aftersaleservice@samsongroup.com).



Documents relating to the device, such as the mounting and operating instructions, are available on our website:  
▶ <https://www.samsongroup.com/en/downloads/documentation>

### Definition of signal words

---

**⚠ DANGER**

*Hazardous situations which, if not avoided, will result in death or serious injury*

---

**⚠ WARNING**

*Hazardous situations which, if not avoided, could result in death or serious injury*

---

**ⓘ NOTICE**

*Property damage message or malfunction*

---

**ℹ Note**

*Additional information*

---

**💡 Tip**

*Recommended action*

---

<b>1</b>	<b>Safety instructions and measures.....</b>	<b>5</b>
1.1	Notes on possible severe personal injury.....	7
1.2	Notes on possible personal injury.....	7
1.3	Notes on possible property damage.....	8
<b>2</b>	<b>Markings on the device.....</b>	<b>9</b>
2.1	Nameplate.....	9
2.2	Location of the nameplate.....	9
<b>3</b>	<b>Design and principle of operation.....</b>	<b>10</b>
3.1	Technical data.....	12
<b>4</b>	<b>Shipment and on-site transport.....</b>	<b>15</b>
4.1	Accepting the delivered goods.....	15
4.2	Removing the packaging from the device.....	15
4.3	Transporting and lifting the device.....	15
4.3.1	Transporting the device.....	15
4.3.2	Lifting the device.....	15
4.4	Storing the device.....	16
<b>5</b>	<b>Installation.....</b>	<b>17</b>
5.1	Installation conditions.....	17
5.2	Preparation for installation.....	17
5.3	Installation.....	17
5.3.1	Installing the device.....	17
5.4	Testing the device.....	17
5.4.1	Leak test.....	18
<b>6</b>	<b>Start-up.....</b>	<b>19</b>
6.1	Start-up and putting the device back into operation.....	19
6.2	Starting up the plant.....	19
6.2.1	Enclosure.....	19
6.2.2	Operating controls.....	19
6.2.3	Type 3423 Controller Module.....	20
6.2.4	Direction of action.....	21
6.2.5	Air output capacity.....	21
6.2.6	Proportional-action coefficient $K_p$ .....	21
6.2.7	Reset time $T_n$ .....	22
6.2.8	Retuning zero point at the controller module.....	22
6.2.9	Supply pressure regulator.....	22
6.3	Start-up and settings of the Type 3423 Controller Module.....	22
<b>7</b>	<b>Operation.....</b>	<b>24</b>
7.1	Operating controls.....	24
7.2	Operating modes.....	24
7.2.1	Automatic mode.....	24
7.2.2	Manual mode.....	24
7.2.3	Bumpless automatic/manual mode changeover.....	24
7.2.4	Bumpless changeover between internal or external set point.....	24
<b>8</b>	<b>Malfunctions.....</b>	<b>26</b>
8.1	Troubleshooting.....	26
8.2	Emergency action.....	26
<b>9</b>	<b>Servicing.....</b>	<b>27</b>
9.1	Service work preparations.....	27
9.2	Service work.....	27
9.2.1	Checking the air filter and restriction.....	27
9.2.2	Adjust the set point of the supply pressure regulator.....	27
9.2.3	Retuning the zero point of the controller module.....	28
9.2.4	Putting the system back into operation after service work.....	28
9.3	Ordering spare parts and operating supplies.....	28
<b>10</b>	<b>Decommissioning.....</b>	<b>29</b>
<b>11</b>	<b>Removal.....</b>	<b>30</b>
11.1	Removing the device.....	30
<b>12</b>	<b>Repair.....</b>	<b>31</b>
12.1	Returning devices to SAMSON.....	31
<b>13</b>	<b>Disposal.....</b>	<b>32</b>

<b>14</b>	<b>Certificates.....</b>	<b>33</b>
<b>15</b>	<b>Appendix.....</b>	<b>35</b>
15.1	Tightening torques.....	35
15.2	Tools.....	35
15.3	Accessories.....	35
15.4	Spare parts.....	35
15.5	After-sales service.....	36

# 1 Safety instructions and measures

## Intended use

The SAMSON Type 7311 Air Control System is suitable for use in simple control applications with one or two control loops. The air control system is delivered as a ready-assembled unit.

The air control system is used in applications in the chemical and petrochemical industries, mechanical and plant engineering as well as general process engineering.

The air control system is designed to operate under exactly defined conditions (e.g. operating pressure, process medium, temperature). Therefore, operators must ensure that the air control system is only used in operating conditions that meet the specifications used for sizing the system at the ordering stage. In case operators intend to use the air control system in applications or conditions other than those specified, contact SAMSON. SAMSON does not assume any liability for damage resulting from the failure to use the device for its intended purpose or for damage caused by external forces or any other external factors.

⇒ Refer to the technical data and nameplate for limits and fields of application as well as possible uses.

## Reasonably foreseeable misuse

The air control system is not suitable for the following applications:

- Use outside the limits defined during sizing and by the technical data
- Use outside the limits defined by the accessories connected to the air control system

Furthermore, the following activities do not comply with the intended use:

- Use of non-original spare parts
- Performing service and repair work not described

## Qualifications of operating personnel

The air control system must be mounted, started up, serviced and repaired by fully trained and qualified personnel only; the accepted industry codes and practices must be observed.

According to these mounting and operating instructions, trained personnel refers to individuals who are able to judge the work they are assigned to and recognize possible hazards due to their specialized training, their knowledge and experience as well as their knowledge of the applicable standards.

## Personal protective equipment

SAMSON recommends checking the hazards posed by the process medium being used (e.g. ►GESTIS hazardous substances database).

Depending on the process medium and/or the activity, the protective equipment required includes:

- Protective clothing, gloves, eye protection and respiratory protection in applications with hot, cold and/or corrosive media
- Wear hearing protection when working near the air control system. Follow the instructions given by the plant operator.
- Hard hat

- Safety harness, e.g. when working at height
  - Safety footwear, if applicable ESD (electrostatic discharge) footwear
- ⇒ Check with the plant operator for details on further protective equipment.

## Revisions and other modifications

Revisions, conversions or other modifications of the air control system are not authorized by SAMSON. They are performed at the user's own risk and may lead to safety hazards, for example. Furthermore, the air control system may no longer meet the requirements for its intended use as a result.

## Warning against residual hazards

To avoid personal injury or property damage, plant operators and operating personnel must prevent hazards that could be caused in the air control system by the process medium, the operating pressure or by moving parts by taking appropriate precautions. Plant operators and operating personnel must observe all hazard statements, warnings and caution notes in these mounting and operating instructions.

Hazards resulting from the special working conditions at the installation site of the air control system must be identified in a risk assessment and prevented through the corresponding safety instructions drawn up by the operator.

SAMSON also recommends checking the hazards posed by the process medium being used (e.g. ►GESTIS hazardous substances database).

⇒ Observe safety measures for handling the device as well as fire prevention and explosion protection measures.

These mounting and operating instructions deal with the standard version of the air control system. Components of the air control system that differ to those used for the standard version described in this document can be exchanged with other certain SAMSON components. The residual hazards of these components are described in the associated mounting and operating instructions (see section 'Referenced documents' in this chapter).

## Safety features

The Type 7311 Air Control System does not have a safety valve. If necessary, a suitable overpressure protection must be installed on site. This prevents the system from being damaged due to excess pressure.

## Responsibilities of the operator

Operators are responsible for proper use and compliance with the safety regulations. Operators are obliged to provide these mounting and operating instructions as well as the referenced documents to the operating personnel and to instruct them in proper operation. Furthermore, operators must ensure that operating personnel or third parties are not exposed to any danger.

Operators are additionally responsible for ensuring that the limits for the air control system defined in the technical data are observed. This also applies to the start-up and shutdown procedures. Start-up and shutdown procedures fall within the scope of the operator's duties and, as such, are not part of these mounting and operating instructions. SAMSON is unable to make any statements about these procedures since the operative details (e.g. differential pressures and temperatures) vary in each individual case and are only known to the operator.

### Responsibilities of operating personnel

Operating personnel must read and understand these mounting and operating instructions as well as the referenced documents and observe the specified hazard statements, warnings and caution notes. Furthermore, operating personnel must be familiar with the applicable health, safety and accident prevention regulations and comply with them.

### Referenced standards, directives and regulations

The air control system complies with the requirements of the European EMC Directive 2014/30/EU and the European RoHS Directive 2011/65/EU.

Chapter 14 contains this declaration of conformity.

### Referenced documents

The following documents apply in addition to these mounting and operating instructions:

- Data sheets for ...
  - e.g. **Type 3423 Pneumatic Controller Modules** ▶T 7521
  - e.g. **Type 4708 Supply Pressure Regulator** ▶T 8546
  - e.g. **Type 3804-1 Pneumatic Transmitter** - ▶T 7540
  - Type 3804-1 Pneumatic Transmitter with Diaphragm Seal** - **Type 814 Pneumatic Transmitter**
  - e.g. **Type 3804-1 Pneumatic Transmitter for Pressure with Diaphragm Seal** ▶T 7550
  - e.g. **Type 3812 Pneumatic Transmitter for Temperature** ▶T 7575
  - e.g. **Type 7491 Pressure Transmitter** ▶T 3991
- Mounting and operating instructions as well as data sheets for additional fittings (e.g. shut-off valves, pressure gauges etc.).

## 1.1 Notes on possible severe personal injury

### **⚠ DANGER**

#### **Risk of bursting due to incorrect opening of pressurized equipment or components.**

The air control system and pipelines are pressure equipment that may burst when handled incorrectly. Flying projectile fragments or the release of process medium under pressure can cause serious injury or even death.

Before working on the air control system:

- ⇒ Before starting any work on the air control system, depressurize all plant sections affected.
- ⇒ Wear personal protective equipment.

#### **Risk of bursting in pressure equipment.**

The air control system and pipelines are pressure equipment. Excessive pressurization or improper opening can lead to device components bursting.

- ⇒ Observe the maximum permissible pressure for the air control system and plant.
- ⇒ If necessary, a suitable overpressure protection must be installed on site in the plant section.
- ⇒ Before starting any work on the air control system, depressurize all plant sections and components affected.
- ⇒ To prevent uncontrolled excess pressure, make sure that suitable overpressure protection is installed on site in the plant section.
- ⇒ Wear personal protective equipment.

#### **Danger due to suspended loads falling.**

- ⇒ Stay clear of suspended or moving loads.
- ⇒ Close off and secure the transport paths.
- ⇒ Wear personal protective equipment.

#### **Risk of personal injury due to the operating medium being released.**

When the unit is operated with nitrogen as the pneumatic supply, nitrogen is released to the atmosphere by the components. Released nitrogen displaces the oxygen in the surrounding air.

- ⇒ Before starting any work on the air control system, depressurize all plant sections and components affected.
- ⇒ Do not start up the air control system until all parts have been mounted.
- ⇒ When the unit is operated with nitrogen as the pneumatic supply: connect a leakage line and discharge the nitrogen to a safe environment (through the roof).
- ⇒ Wear personal protective equipment.

## 1.2 Notes on possible personal injury

### **⚠ WARNING**

#### **Risk of hearing loss or deafness due to loud noise.**

The noise emissions depend on the version of the air control system, the plant facilities and process medium.

- ⇒ Wear hearing protection when working near the system. Follow the instructions given by the plant operator.

#### **Damage to health relating to the REACH regulation.**

If a SAMSON device contains a substance listed as a substance of very high concern on the candidate list of the REACH regulation, this is indicated on the SAMSON delivery note.

- ⇒ Information on safe use of the part affected. See [www.samsongroup.com](http://www.samsongroup.com) > ABOUT SAMSON > Environment, Social & Governance > Material Compliance > REACH Regulation
- ⇒ Wear eye protection when working in close proximity to the system.

#### **Risk of lifting equipment tipping over and risk of damage to lifting accessories due to exceeding the rated lifting capacity.**

- ⇒ Only use approved lifting equipment and accessories whose minimum lifting capacity is higher than the weight of the air control system.
- ⇒ Refer to Chapter 3.1 for weights.

#### **Risk of personal injury due to incorrect operation, use or installation as a result of information on the air control system being illegible.**

Over time, markings, labels and nameplates on the air control system may become covered with dirt or become illegible in some other way. As a result, hazards may go unnoticed and the necessary instructions not followed. There is a risk of personal injury.

- ⇒ Keep all relevant markings and inscriptions on the air control system in a constantly legible state.
- ⇒ Immediately renew damaged, missing or incorrect nameplates or labels.

#### **Risk of injury due to incorrect lifting without the use of lifting equipment.**

Lifting the air control system without the use of lifting equipment may lead to injuries (back injury in particular) depending on its weight.

- ⇒ Observe the guideline weight for manual handling: 15 to max. 55 kg taking into account age, gender and physical fitness.
- ⇒ Observe the occupational health and safety regulations valid in the country of use.

#### **Risk of personal injury due to pressurized components and the operating medium being released.**

- ⇒ Do not unscrew the supply air line while the air control system is pressurized.
- ⇒ Do not start up the air control system until all parts have been mounted.
- ⇒ Wear goggles when working near the system. Follow the instructions given by the plant operator.

## 1.3 Notes on possible property damage

### ! NOTICE

#### **Risk of damage to the air control system and downstream devices due to failure to meet air quality requirements.**

An insufficient air quality may lead to the output signal not being proportional to the input signal.

- ⇒ Only use supply air that is dry and free of oil and dust.
- ⇒ Comply with air quality requirements for the air control system and downstream device.
- ⇒ Blow through all air pipes and hoses thoroughly before connecting them.

#### **Risk of damage due to the use of unsuitable lubricants.**

The lubricants to be used depend on the material of the device. Unsuitable lubricants may corrode and damage surfaces.

- ⇒ Only use lubricants approved by SAMSON. When in doubt, consult SAMSON.

#### **A zero shift, malfunction or device damage may occur due to vibration, shocks or jolting.**

Vibration, shocks or jolts can cause a zero shift and impair correct functioning. In extreme cases, they may damage the device.

- ⇒ Protect the device against external influences (e.g. vibrations, impact, jolts or shocks).

#### **Risk of malfunction due to failure to comply with air quality requirements.**

An insufficient air quality may lead to the output signal not being proportional to the input signal.

- ⇒ Make sure that the air quality complies with the requirements.
- ⇒ Check the air filter and separator installed in the upstream air reducing station regularly.

#### **The Type 7311 Air Control System does not have a safety valve.**

- ⇒ If necessary, a suitable overpressure protection must be installed on site in the plant section.

#### **Risk of damage or leakage due to over- or under-torquing.**

Observe the specified torques when tightening components. Over-torquing leads to parts wearing out more quickly. Under-torquing may cause leakage.

- ⇒ Observe the specified tightening torques (see Chapter 15.1).

#### **Risk of damage due to improper storage.**

- ⇒ Observe the storage instructions.
- ⇒ Avoid long storage times.
- ⇒ Contact SAMSON in case of different storage conditions or longer storage periods.

#### **Risk of damage or blockage due to contamination (e.g. solid particles) in the supply air line and signal lines.**

The plant operator is responsible for cleaning the supply air line and signal lines in the plant.

- ⇒ Flush the supply air line and signal lines before start-up.

#### **Risk of damage due to incorrect service or repair work.**

Do not perform any repair work on your own.

- ⇒ Contact SAMSON's After-sales Service for service and repair work.



## 2 Markings on the device

A nameplate is affixed to the Type 7311. The nameplate shown was up to date at the time of publication of this document. The nameplate on the device may differ from the one shown.

### 2.1 Nameplate

<b>SAMSON</b>		CE 	
Pneum. Regelsystem		⑩	
Model:	①		
Mat.:	②	S/N:	③
Degree of protection:	IP54 ④	Max. air pressure:	6 barg ⑤
Operating voltage:	⑥		
Nominal current:	⑦		
Determination:	⑧		
Year of manufacture:	⑨		
SAMSON AG D-60314 Frankfurt		Made in Germany	

**Fig. 1:** Nameplate of Type 7311

- 1 Type designation
- 2 Material number
- 3 Serial number
- 4 Degree of protection
- 5 Max. supply pressure
- 6 Operating voltage
- 7 Rated capacity
- 8 Directives applied
- 9 Date of manufacture
- 10 CE marking

### 2.2 Location of the nameplate

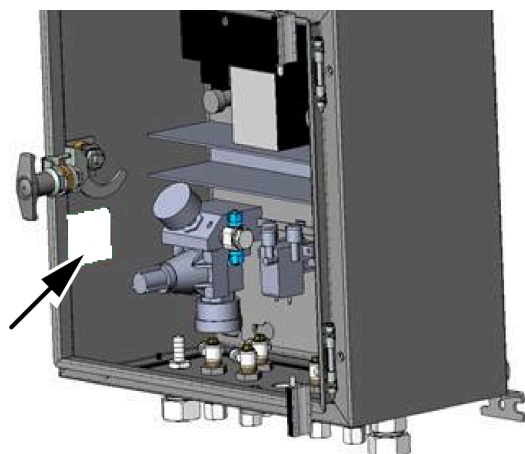

**Fig. 2:** Location of the nameplate

### 3 Design and principle of operation

⇒ See Fig. 3.

The Type 7311 Air Control System consists of one control loop or two control loops that work independently from one another. The air control system is supplied as a turnkey system.

The installed Type 3423 Controller Module is used to maintain the predefined set point  $w$  constant in the control loop. A second controller module is installed when two control loops are controlled.

For the sake of simplicity, the function with one control loop is described below. The function and set-up of the second control loop are identical to those of the first control loop. All operating controls are located on the front panel of the air control system.

The pressure indicator (60H0 and 70H0) indicates whether the supply air is applied to the air control system (green = connected, black = not connected).

The set point  $w$  is set at the rotary button (60A2 or 70A2). The reading of the controlled variable  $x$  (red pointer) and the set

point  $w$  (green pointer) can be read off at the double pressure gauge 60P5 or 70P5.

The controlled variable  $x$  is transmitted by an optional pressure or temperature transmitter as a standardized 0.2 to 1 bar signal connected to the air control system.

The control signal  $y$  is issued to a connected control valve depending on the mode (manual/automatic) selected at the switch 60S1 or 70S1.

Optionally the set point  $w$  can be transmitted by an electrical pressure transmitter and issued as a 4 to 20 mA signal (Type 7311-03).

Optionally the set point  $w$  can be set externally using an external analog signal. In this case, the air control system has an additional 0.2 to 1 bar input and a switch to switch  $w_{int}$  to  $w_{ext}$  (Type 7311-03).

The pressure gauge 60P4 or 70P4 for the  $y_A$  output signal and the pressure gauge 60P3 or 70P3 for the  $y_H$  output signal are used for bumpless changeover and pressure readings.



Fig. 3: Type 7311-01/-02/-03 Air Control System with connections

Designation of controls in control loop One   Two	Component	Function
60P5   70P5	Double pressure gauge	Reading of controlled variable $x$ and set point $w$
60A2   70A2	Rotary knob	Adjuster for set point $w$
60H0   70H0	Pressure indicator	Indicator for operating pressure I/O
60P4   70P4	Pressure gauge	Control signal reading in automatic mode $y_H$
60P3   70P3	Pressure gauge	Control signal reading in manual mode $y_H$
60S1   70S1	Switch	Manual/automatic switch
60A1   70A1	Rotary knob	Adjuster for control signal $y_H$

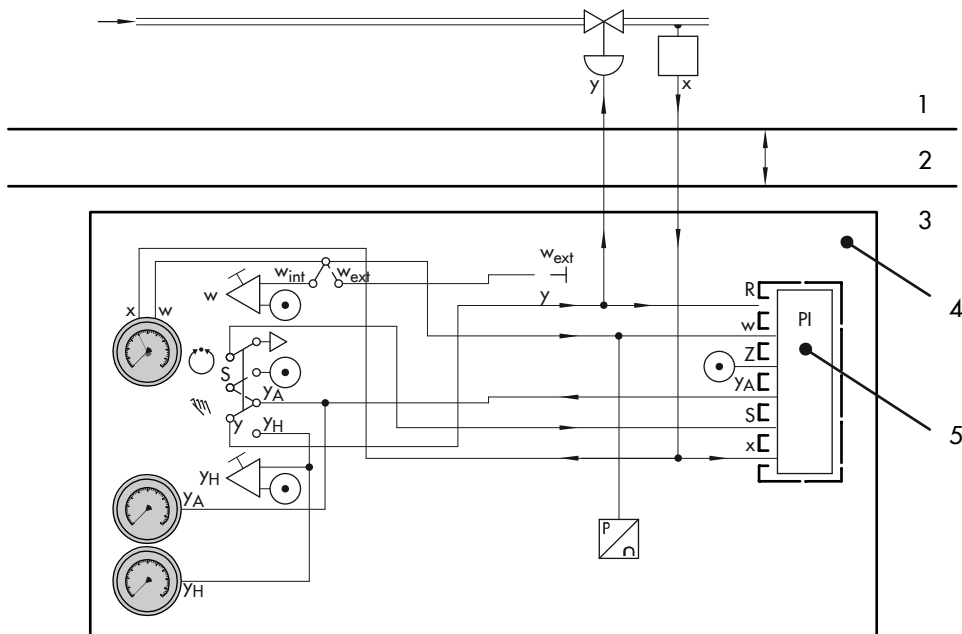
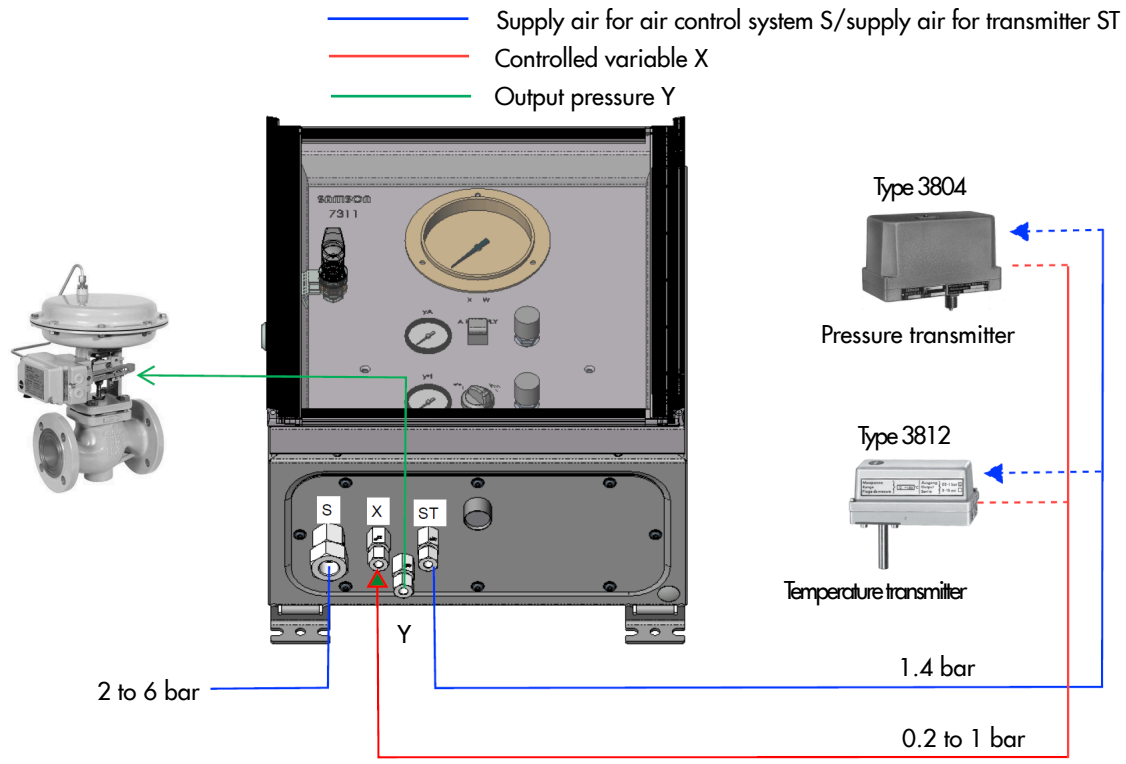

**Fig. 4:** Instrumentation and wiring in the Type 7311 Air Control System

- 1 Field
- 2 Transmission path
- 3 Control room
- 4 Type 7311 Air Control System
- 5 Type 3423-2 Controller Module with Type 3426-5 Control Room Housing

### 3.1 Technical data

The nameplate on the air control system contains information on the system version (see Chapter 2).

**i Note**

More information is available in Data Sheet ▶ T 3992.

#### Conformity

The Type 7311 Air Control System bears the CE mark of conformity.



#### Process medium and scope of application

The Type 7311 Air Control System is used to determine a pneumatic standardized signal and display the operating value. These measured variables are compared internally with the set point  $w$  and issued as a corresponding pneumatic control signal from 0.2 to 1 bar.

- For **PI control** (fixed set point, follow-up and cascade control)
- Max. temperature **60 °C**
- Input signal **0.2 to 1 bar**
- Output signal **0.2 to 1 bar · Max. 0.02 to 1.35 bar**
- Air output capacity **>1 Nm<sup>3</sup>/h**

#### Temperature range

Depending on how the air control system is configured, it can be used up to temperatures of 60 °C (see Table 1).

#### Noise emissions

SAMSON is unable to make general statements about noise emissions. The noise emissions depend on the version of the air control system, the plant facilities and operating conditions.

#### Dimensions and weights

Table 1 provides a summary of the weights. The lengths and heights are shown in Fig. 5.

**Table 1: Technical data**

Version	7311-01	7311-02	7311-03
Quantity of Type 3423 Controller Modules	1	2	1 or 2
Set point/controlled variable display	Double Bourdon tube pressure gauge, signal range: 0.2 to 1 bar Accuracy class 1.6		
Output indication	One pressure gauge each for $y_H$ and $y_A$ : 0 to 1.6 bar Accuracy class 1.6		
Function of the controller module	PI Fixed set point control		PI Fixed set point, follow-up and cascade control
Control parameters	Proportional-action coefficient $K_p = 0.2$ to $20$ · Reset time $T_n = 0.03$ to $50$ min.		
Input signal	0.2 to 1 bar		
Output signal	0.2 to 1 bar · Max. 0.02 to 1.35 bar		
Air output capacity	>1 Nm <sup>3</sup> /h		
Input of the set point	Local		Local or remote setting
Supply	Supply air 6.0 bar, air consumption <0.28 Nm <sup>3</sup> /h	Supply air 6.0 bar, air consumption <0.56 Nm <sup>3</sup> /h	Supply air 6.0 bar, air consumption <0.28 Nm <sup>3</sup> /h per controller module
Air quality acc. to ISO 8573-1	Maximum particle size and density: Class 3 · Oil content: Class 2 · Pressure dew point: Class 3 or at least 10 K below the lowest ambient temperature to be expected		
Permissible ambient temperature	-20 to 60 °C		
Degree of protection	IP54		
Dials	Standard ranges: Pressure in bar: 0 to 4, 0 to 6, 0 to 8, 0 to 10, 0 to 16, 0 to 20 Temperature in °C: -50 to +50, 0 to 100, 0 to 200		Standard ranges, special ranges on request
Set point feedback	-		Optionally with 4 to 20 mA per controller module
Weight, approx.	15 kg	20 kg	25 kg

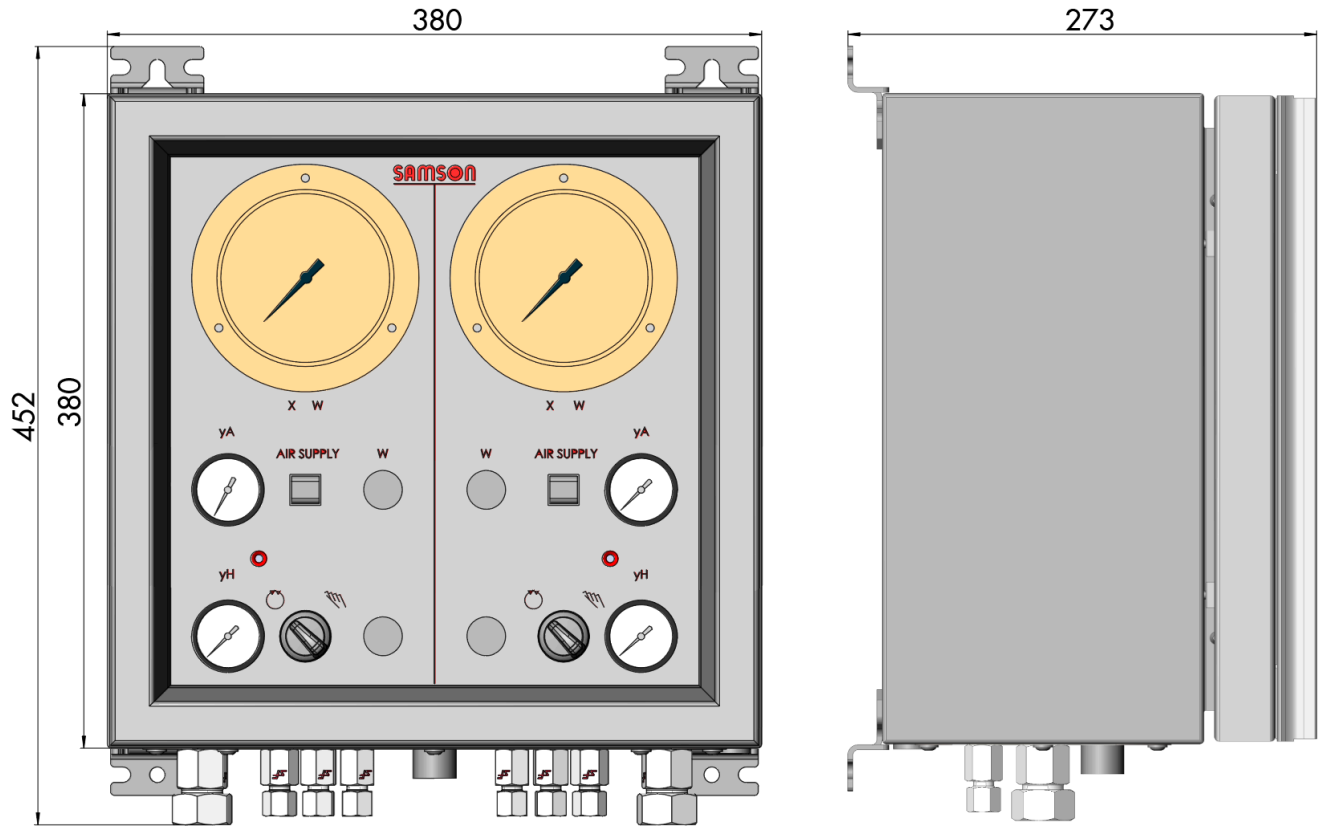

Fig. 5: Dimensions of Type 7311

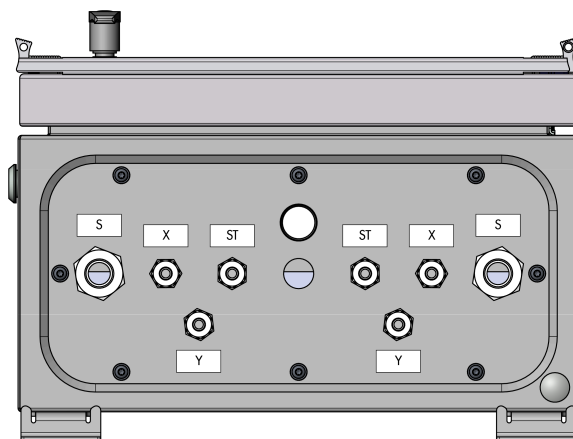

Fig. 6: Connections of Type 7311

Control loop 1	
S	Supply air
X	Controlled variable (actual value) input
ST	Supply air for transmitter
Y	Control signal output
Control loop 2	
S	Supply air
X	Controlled variable (actual value) input
ST	Supply air for transmitter
Y	Control signal output

Connection	Dimensions	Pressure range	Min./Max.
S	18x2 mm <sup>1)</sup>	Max. 6 bar	Max. 6 bar
X	8x1 mm <sup>1)</sup>	0.2 to 1 bar	0 bar/1.4 bar
Y			0 bar/1 bar
ST		1.4 bar	-
Cable duct	M20 cable gland	-	10 to 32 VDC

<sup>1)</sup> Compression-type fitting

## 4 Shipment and on-site transport

The work described in this chapter is to be performed only by personnel appropriately qualified to carry out such tasks.

### 4.1 Accepting the delivered goods

After receiving the shipment, proceed as follows:

1. Check the scope of delivery. Check that the specifications on the nameplate of the air control system match the specifications in the delivery note. See Chapter 2 for more details on the nameplate.
2. Check the shipment for transportation damage. Report any damage to SAMSON and the forwarding agent (refer to delivery note).

### 4.2 Removing the packaging from the device

**The air control system is delivered as a ready-assembled unit.**

Proceed as follows to lift and install the air control system:

- ⇒ Leave the air control system on the pallet to transport it on site.
- ⇒ Dispose and recycle the packaging in accordance with the local regulations.

### 4.3 Transporting and lifting the device

#### WARNING

**Risk of injury due to incorrect lifting without the use of lifting equipment.**

*Lifting the air control system without the use of lifting equipment may lead to injuries (back injury in particular) depending on its weight.*

- ⇒ *Observe the guideline weight for manual handling: 15 to max. 55 kg taking into account age, gender and physical fitness.*
- ⇒ *Observe the occupational health and safety regulations valid in the country of use.*

#### Tip

*Our after-sales service can provide more detailed transport and lifting instructions on request.*

#### 4.3.1 Transporting the device

- ⇒ Leave the air control system on the pallet to transport it on site.
- ⇒ Observe the transport instructions.

##### Transport instructions

- ⇒ Protect the air control system against external influences (e.g. impact).
- ⇒ Do not damage the corrosion protection (paint, surface coatings). Repair any damage immediately.
- ⇒ Protect the piping and any mounted valve accessories against damage.
- ⇒ Protect the air control system against moisture and dirt.
- ⇒ The permissible ambient temperature of the standard air control system is  $-20$  to  $+60$  °C.

#### 4.3.2 Lifting the device

Due to the low service weight, lifting equipment is not required to transport and lift the air control system.

##### Lifting

1. Carefully lift the air control system.
2. Install the air control system (see Chapter 5).
3. After installation:  
Check whether the air control system is properly installed.

## 4.4 Storing the device

---

### NOTICE

#### **Risk of damage due to improper storage.**

- ⇒ Observe the storage instructions.
  - ⇒ Avoid long storage times.
  - ⇒ Contact SAMSON in case of different storage conditions or longer storage periods.
- 

### Note

SAMSON recommends to regularly check the air control system and the prevailing storage conditions during long storage periods.

---

### Storage instructions

- ⇒ Protect the air control system against external influences (e.g. impact).
  - ⇒ Secure the air control system in the stored position against slipping or tipping over.
  - ⇒ Do not damage the corrosion protection (paint, surface coatings). Repair any damage immediately.
  - ⇒ Protect the air control system against moisture and dirt. Store it at a relative humidity of less than 75 %. In damp spaces, prevent condensation. If necessary, use a drying agent or heating.
  - ⇒ Make sure that the ambient air is free of acids or other corrosive media.
  - ⇒ The permissible storage temperature of the standard air control system is  $-20$  to  $+60$  °C.
  - ⇒ Do not place any objects on the air control system.
- 

### Tip

Our after-sales service can provide more detailed storage instructions on request.

---



## 5 Installation

The work described in this chapter is to be performed only by personnel appropriately qualified to carry out such tasks.

### 5.1 Installation conditions

#### Work position

The work position for the air control system is the front view onto all operating controls on the system (including any additional fittings) seen from the position of operating personnel. Plant operators must ensure that, after installation of the device, the operating personnel can perform all necessary work safely and easily access the device from the work position.

#### Mounting position

To ensure that the air control system functions properly, proceed as follows:

1. Mount the air control system on a wall with the connections facing downward.
2. Allow sufficient space to open the door.
3. Contact SAMSON if the mounting position is not as specified above.

#### **i** Note

Make sure that the air control system remains freely accessible after the plant has been completed.

⇒ Allow sufficient space to remove any components.

### 5.2 Preparation for installation

Before installation, make sure the following conditions are met:

- Ensure that there is no liquid, e.g. condensed water, inside the air control system.
- The air control system is clean.
- No components in the air control system are damaged.
- All data on the nameplate (type designation, nominal size, material, pressure rating and temperature range) match the plant conditions. See Chapter 2 for more details on the nameplate.

Proceed as follows:

⇒ Lay out the necessary material and tools to have them ready during installation work.

### 5.3 Installation

The SAMSON Type 7311 Air Control System is delivered as ready-assembled and tested unit. The activities listed below are necessary for installation and before start-up of the air control system.

#### **!** NOTICE

**Risk of damage or leakage due to over- or under-torquing.** Observe the specified torques when tightening components. Over-torquing leads to parts wearing out more quickly. Under-torquing may cause leakage.

⇒ Observe the specified tightening torques (see Chapter 15.1).

### 5.3.1 Installing the device

#### Installation

1. Lift the air control system to the site of installation. Make sure that the unit is mounted in a horizontal position on the wall.
2. Connect all required supply lines (see connections in Fig. 7).



Fig. 7: Type 7311-01/-02/-03 Air Control System with connections

Control loop 1	
S	Supply air
X	Controlled variable (actual value) input
ST	Supply air for transmitter
Y	Control signal output
Control loop 2	
S	Supply air
X	Controlled variable (actual value) input
ST	Supply air for transmitter
Y	Control signal output

Connection	Dimensions	Pressure range	Min./Max.
S	18x2 mm <sup>1)</sup>	Max. 6 bar	Max. 6 bar
X	8x1 mm <sup>1)</sup>	0.2 to 1 bar	0 bar/1.4 bar
Y			0 bar/1 bar
ST		1.4 bar	–
Cable duct	M20 cable gland	–	10 to 32 VDC

<sup>1)</sup> Compression-type fitting

### 5.4 Testing the device

The SAMSON air control systems are delivered ready for use. To test the functioning of the air control system before start-up or putting back it into operation, perform the following tests:

To check the air control system, the controlled variable **x** and the output **y** must be bypassed at ports **x** and **y** in the air control system.

#### Perform the following settings:

- Turnboard **A** to increasing/decreasing > <
- Set Kp to 1

## Installation

- Fully open Tn restriction (0.03 min)
- Select automatic mode

### Perform the following test:

⇒ Turn the rotary knob (60A2/70A2) to change the set point  $w$  through its whole range.

The controlled variable pointer (red) and the output reading ( $y_A$  pressure gauge dial) follow the set point over the whole range when the controller module functions properly.

### 5.4.1 Leak test

The plant operator is responsible for performing the leak test and selecting the test method. The leak test must comply with the requirements of the national and international standards that apply at the site of installation.



#### Tip

*SAMSON's After-sales Service can support you to plan and perform a leak test for your plant.*

---

Before start-up of the air control system, check all the components and lines to make sure that they are connected correctly, do not leak and function properly.

## 6 Start-up

The work described in this chapter is to be performed only by personnel appropriately qualified to carry out such tasks.

### **⚠ DANGER**

#### **Risk of personal injury due to the operating medium being released.**

When the unit is operated with nitrogen as the pneumatic supply, nitrogen is released to the atmosphere by the components. Released nitrogen displaces the oxygen in the surrounding air.

- ⇒ Before starting any work on the air control system, depressurize all plant sections and components affected.
- ⇒ Do not start up the air control system until all parts have been mounted.
- ⇒ When the unit is operated with nitrogen as the pneumatic supply: connect a leakage line and discharge the nitrogen to a safe environment (through the roof).
- ⇒ Wear personal protective equipment.

### **⚠ WARNING**

#### **Risk of hearing loss or deafness due to loud noise.**

The noise emissions depend on the version of the air control system, the plant facilities and process medium.

- ⇒ Wear hearing protection when working near the system. Follow the instructions given by the plant operator. Wear hearing protection when working near the system. Follow the instructions given by the plant operator.

### **⚠ WARNING**

#### **Risk of personal injury due to pressurized components and the operating medium being released.**

- ⇒ Do not unscrew the supply air line while the air control system is pressurized.
- ⇒ Do not start up the air control system until all parts have been mounted.
- ⇒ Wear goggles when working near the system. Follow the instructions given by the plant operator.

Before start-up or putting the device back into service, make sure the following conditions are met:

- The air control system is properly installed (see Chapter 5).
- The leak and function tests have been completed successfully (see Chapter 5).
- The prevailing conditions in the plant section affected meet the sizing requirements of the air control system (see Chapter 1).

## 6.1 Start-up and putting the device back into operation

1. Slowly open the shut-off valves on site in the supply air line. Slowly opening these valves prevents a sudden surge in pressure which may damage the air control system.
2. Check the air control system to ensure it functions properly.

Before starting up the plant, make sure the following conditions are met:

- The supply air line and signal lines are open and correctly connected.

## 6.2 Starting up the plant

### Starting up the plant (see page 22 onwards)

⇒ Avoid pressure surges.

1. The supply air line and signal lines are correctly connected and open.

### 6.2.1 Enclosure

Open the window (1) at the T-handle (2) to access the operating controls.

To access the controller module inside the enclosure, turn the lock (3) on the enclosure. Use the supplied double-bit key to unlock the enclosure.

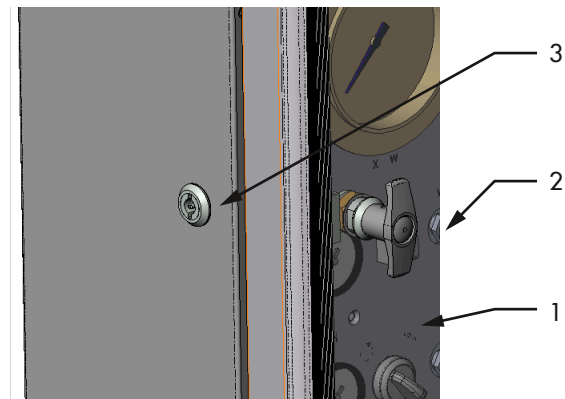

Fig. 8: Enclosure of air control system

- 1 Window
- 2 T-handle
- 3 Lock

### 6.2.2 Operating controls

Fig. 9 shows all the operating controls on the Type 7311 Air Control System.



Fig. 9: Type 7311-01/-02/-03 Air Control System with connections

Designation of controls in control loop One   Two	Component	Function
60P5   70P5	Double pressure gauge	Reading of controlled variable $x$ and set point $w$
60A2   70A2	Rotary knob	Adjuster for set point $w$
60H0   70H0	Pressure indicator	Operating pressure indicator I/O
60P4   70P4	Pressure gauge	Control signal reading in automatic mode $y_H$
60P3   70P3	Pressure gauge	Control signal reading in manual mode $y_H$
60S1   70S1	Switch	Manual/automatic switch
60A1   70A1	Rotary knob	Adjuster for control signal $y_H$

### 6.2.3 Type 3423 Controller Module

See Fig. 10.

The Type 3423 Controller Module compares the controlled variable  $x$  with the set point  $w$ . It issues a corresponding control signal  $y_A$  based on the PI control characteristic.

The controlled variable  $x$  is transmitted by an optional Type 3804 Pressure Transmitter or the Type 3812 Pneumatic Transmitter for Temperature.

**NOTICE**

**Risk of malfunction due to failure to comply with air quality requirements.**

An insufficient air quality may lead to the output signal not being proportional to the input signal.

- ⇒ Make sure that the air quality complies with the requirements.
- ⇒ Check the air filter and separator installed in the upstream air reducing station regularly.

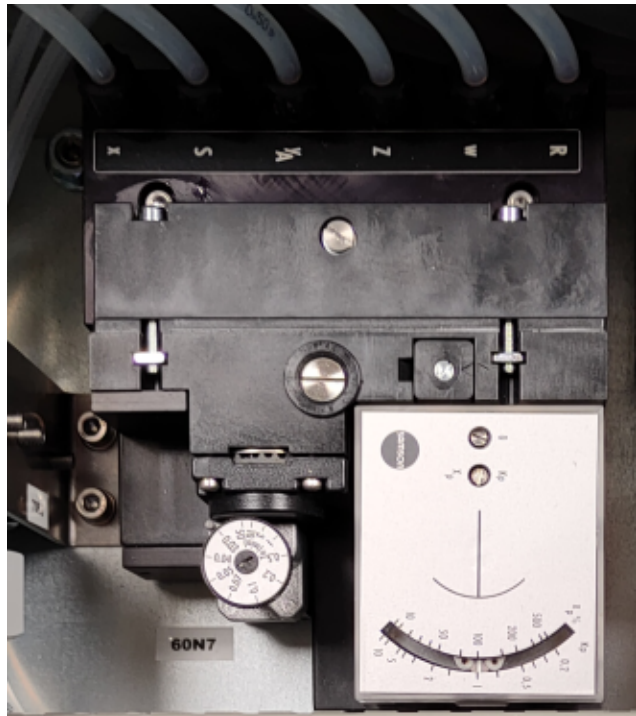

Fig. 10: Type 3423 Pneumatic Controller Module

### 6.2.4 Direction of action

The direction of action for the control loop is set at the **turnboard A**, where the position of its arrow symbol according to the arrow symbol on the controller module determines the direction of action of the controller module (see Fig. 11).

< >	Arrow tips facing opposite directions: Direction of action increasing/decreasing As the controlled variable $x$ increases, the control signal $y$ falls
>>	Arrow tips facing the same direction: Direction of action increasing/increasing As the controlled variable $x$ increases, the control signal $y$ increases

#### Setting or changing the direction of action:

Undo the screw in **turnboard A** and lift it off together with the turnboard. If necessary, lever the board at the side. Do not lose the rubber seal.

- Turn the board by 90° so that the required arrow is aligned with the arrow on the base plate.
- Insert board and tighten the screw.

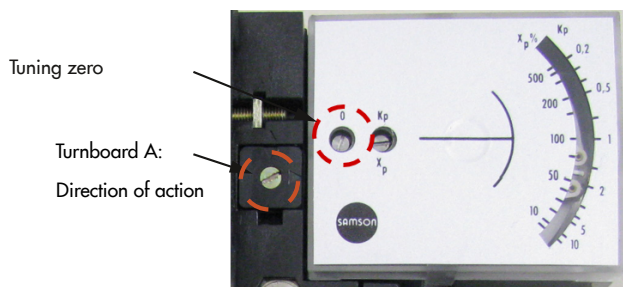

Fig. 11: Position of the turnboard A and zero adjustment

### 6.2.5 Air output capacity

The position of **turnboard B** with its arrow symbol determines the air delivery to the feedback bellows (see Fig. 13).

> $y_A$	Normal air delivery: Approx. 1 m <sub>n</sub> <sup>3</sup> /h per % of the system deviation (default setting)
> $R$	High air delivery: Approx. 3 m <sub>n</sub> <sup>3</sup> /h per % of the system deviation

#### Setting or changing the air delivery (see Fig. 12 and Fig. 13)

If the control valve that is to be controlled is more than 15 meters away, increase the air delivery by turning the position of **turnboard B** from  $y_A$  (default) to  $R$ .

1. Unscrew the fastening screw (2) at the controller module and pull the module off its self-seal push-on fittings.
2. Undo screws (1) and pull off the connecting plate (3) together with square nuts and bolts from the controller module.
3. Unscrew the hexagonal socket head screws (4) at the side and lift the comparator (5) off the controller module.
4. Undo the screw in **turnboard B** and lift it off together with the turnboard. If necessary, lever the board at the side. Do not lose the rubber seal.

5. Turn the board so that the arrow is aligned with  $y_A$  or  $R$  on the controller module. Insert board and tighten the screw.
6. Remount the controller module in the reverse order and fasten it in the controller station.

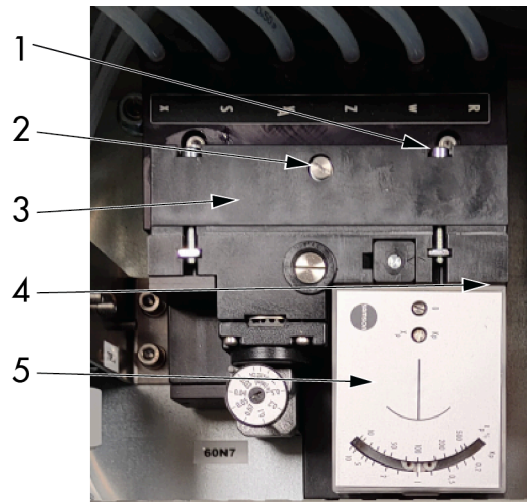

Fig. 12: Turning the position of turnboard B

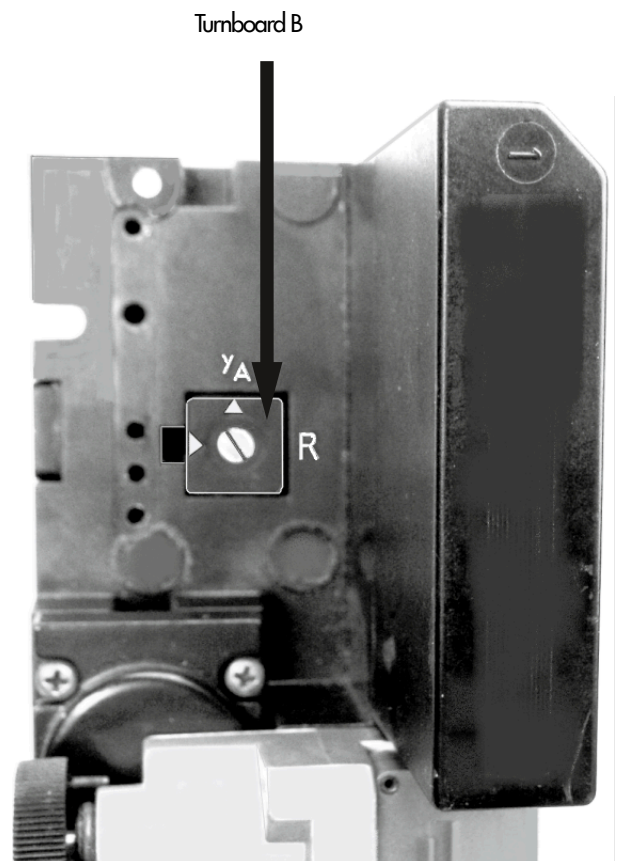

Fig. 13: Position of turnboard B

### 6.2.6 Proportional-action coefficient Kp

The setting of the **Kp** (see Fig. 14) determines the gain of the controller module and depends on the controlled system being tuned (see Chapter 6.3).

### 6.2.7 Reset time Tn

Set the reset time Tn (integral action of the controller module) at the adjuster (see Fig. 14). The setting depends on the controlled system being tuned (see Chapter 6.3).

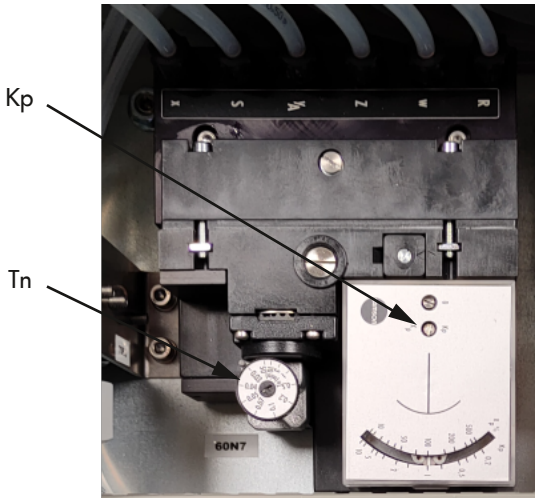

Fig. 14: Position of Kp and Tn adjusters

### 6.2.8 Retuning zero point at the controller module

If deviations arise between the controlled variable and set point during operation, the zero point can be retuned. Turn the zero adjuster (see Fig. 11) until the controlled variable and set point on the front display coincide.

### 6.2.9 Supply pressure regulator

**NOTICE**

**Risk of damage to the air control system due to excessively high upstream pressure.**

The installed supply pressure regulator has a maximum inlet pressure and a fixed set point adjustment.

⇒ The maximum inlet pressure at the supply pressure regulator must not exceed 6 bar.

⇒ The supply pressure regulator is set to 1.4 bar (+/- 0.1 bar) in the delivered state. A different setting is not permissible.

One supply pressure regulator is installed for each control loop in the Type 7311 Air Control System (see Fig. 15). These supply pressure regulators are ready adjusted to supply the unit with supply air (or another operating medium).



Fig. 15: Setup inside the Type 7311 Air Control System

- 1 Supply pressure regulator for control loop 2 (50R6)
- 2 Supply pressure regulator for control loop 1 (50R5)

### 6.3 Start-up and settings of the Type 3423 Controller Module

Before start-up of the control loop, check all devices to make sure that they are connected correctly, do not leak and function properly.

Check the turnboard to make sure the correct direction of action is set at the controller module (see Chapter 6.2.4).

The controller module needs to be tuned to the characteristics of the controlled system using the Kp and Tn adjusters at the controller module (see Fig. 14) to ensure that the controller module can keep any system deviations for all set points caused by the disturbance variables to zero or at least minimize them. Start up the system manually.

The tuning test following the Ziegler and Nichols method is a simple way to tune the controller.

**Proceed as follows:**

1. Open the supply air line upstream of the air control system.
2. Set the proportional-action coefficient **Kp** to a low value (0.2) at the comparator.
3. Set the **Tn** restrictor to its maximum value (50 min).

**Setting for manual mode:**

4. Set the manual/automatic switch **60S1/70S1** to the manual mode.
5. Turn the adjuster **60A1/70A1** for the control signal until the controlled variable **x** (red pointer on the double pressure gauge **60P5/70P5**) slowly settles on the adjusted set point **w** (green pointer on the double pressure gauge **60P5/70P5**). After the pressure readings at the pressure gauges **60P4/70P4** and **60P3/70P3** coincide, turn the switch **60S1/70S1** to the automatic mode. **Proceed as described in step 9.**

#### Setting for automatic mode:

6. Turn the rotary knob **60A2/70A2** to adjust the set point to the required value.
7. Briefly set the **Tn** restrictor to its minimum setting (fully open) to allow the red controlled variable pointer to move to the green set point pointer.
8. Close the **Tn** restrictor again.
9. Starting from a low value, increase the proportional-action coefficient **Kp** until the controlled variable pointer shows an harmonic oscillation pattern (uniform oscillation amplitudes as shown in Fig. 16). If oscillations do not arise with a large **Kp** setting, turn the rotary knob to slightly change the set point and then return it to its former setting. It may be necessary to increase the gain (**Kp**) slightly until an harmonic oscillation pattern arises.
10. Write down the adjusted value on the **Kp** scale you have just adjusted as the critical proportional-action coefficient **Kp<sub>crit</sub>**. Use a stopwatch to time the oscillation time for one entire oscillation to find **T<sub>crit</sub>**. Multiply both values with the values in Table 2 and set them as the favorable settings for **Kp** and **Tn** at the controller module.  
Should oscillations still occur despite these settings, slightly reduce **Kp** and increase **Tn**. Repeat these steps, if necessary, until the control loop shows a satisfactory performance.  
Leave enough time between settings to allow the controller module to stabilize.

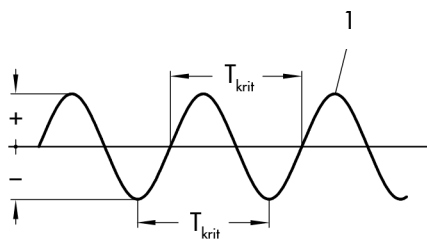

Fig. 16: Harmonic oscillation pattern

1 Controlled variable (actual value)

Table 2: Adjustment values

Controller	<b>Kp</b>	<b>Tn</b>	<b>Tv</b>
P	$0.5 * K_{p_{crit}}$	–	–
PI <sup>1)</sup>	$0.45 * K_{p_{crit}}$	$0.85 * T_{crit}$	–
PID	$0.59 * K_{p_{crit}}$	$0.50 * T_{crit}$	$0.12 * T_{crit}$

1) PI controller module for Type 7311 Air Control System

## 7 Operation

Immediately after completing start-up or putting the unit back into operation and the supply air is connected to **S**, the air control system is ready for use.

The connected state of the supply air is indicated at the pressure indicator **60H0/70H0** (see Chapter 6).

The air control system is operated on site using the operating controls on the front.

### **⚠ WARNING**

**Danger due to hazardous conditions arising in the plant.**  
Upon failure of the supply air in automatic mode and reconnecting the supply air, make sure that no hazardous conditions arise in the controlled process.  
⇒ Before reconnecting the supply air, check the condition of the controlled process.

### **⚠ DANGER**

**Risk of personal injury due to the operating medium being released.**  
When the unit is operated with nitrogen as the pneumatic supply, nitrogen is released to the atmosphere by the components. Released nitrogen displaces the oxygen in the surrounding air.

- ⇒ Before starting any work on the air control system, depressurize all plant sections and components affected.
- ⇒ Do not start up the air control system until all parts have been mounted.
- ⇒ When the unit is operated with nitrogen as the pneumatic supply: connect a leakage line and discharge the nitrogen to a safe environment (through the roof).
- ⇒ Wear personal protective equipment.

### **⚠ WARNING**

**Risk of hearing loss or deafness due to loud noise.**  
The noise emissions depend on the version of the air control system, the plant facilities and process medium.  
⇒ Wear hearing protection when working near the system. Follow the instructions given by the plant operator. Wear hearing protection when working near the system. Follow the instructions given by the plant operator.

### **⚠ WARNING**

**Risk of personal injury due to pressurized components and the operating medium being released.**  
⇒ Do not unscrew the supply air line while the air control system is pressurized.  
⇒ Do not start up the air control system until all parts have been mounted.  
⇒ Wear goggles when working near the system. Follow the instructions given by the plant operator.

### 7.1 Operating controls

All operating controls are located on the front panel of the air control system (see Chapter 3).

## 7.2 Operating modes

### 7.2.1 Automatic mode

After the manual/automatic switch **60S1/70S1** is set to automatic mode, the control signal **y** is determined by the controller module. The control signal **y<sub>A</sub>** can be read off at the pressure gauge **60P4/70P4**.



The set point **w** is set at the adjuster **60A2/70A2**. The set point **w** can be read off at the pressure gauge **60P5/70P5** (green pointer on the double pressure gauge).



### 7.2.2 Manual mode

After the manual/automatic switch **60S1/70S1** is set to the manual mode, the control signal **y** is set at the adjuster **60A1/70A1**.



The control signal **y<sub>H</sub>** can be read off at the pressure gauge **60P3/70P3**.



### 7.2.3 Bumpless automatic/manual mode changeover

The bumpless changeover ensures that no pressure surges can reach the valve when the manual/automatic switch **60S1/70S1** is activated as follows:

#### Changeover from automatic to manual

Turn the adjuster **60A1/70A1** to adjust the control signal for manual mode **y<sub>H</sub>** until the readings on the pressure gauges **60P3/70P3** and **60P4/70P4** coincide. You can now switch the manual/automatic switch **60S1/70S1** to the manual mode.

#### Changeover from manual to automatic

If the system is controlled manually to the required value, the control signal **y<sub>A</sub>** must be adjusted at the rotary knob **60A2/70A2** to match the control signal **y<sub>H</sub>**. Do not turn the manual/automatic switch **60S1/70S1** to the automatic mode before the readings at the pressure gauges **60P3/70P3** and **60P4/70P4** coincide.

Afterwards, adjust the set point **w** again to the required value.

### 7.2.4 Bumpless changeover between internal or external set point

The bumpless changeover between internal or external set point is only possible as an option for Type 3423-03 Controller Module.

For the bumpless changeover between internal or external set point, it is essential that both values coincide before switching.

Proceed as follows:

1. Switch the control loop to the manual mode (see Chapter 7.2.3).
2. Switch the **w<sub>int</sub>/w<sub>ext</sub>** switch to **w<sub>ext</sub>** (see Fig. 17).
3. The green set point pointer on the pressure gauge **60P5/70P6** coincides with the previously adjusted internal set point.
4. Switch the control loop back to the automatic mode.



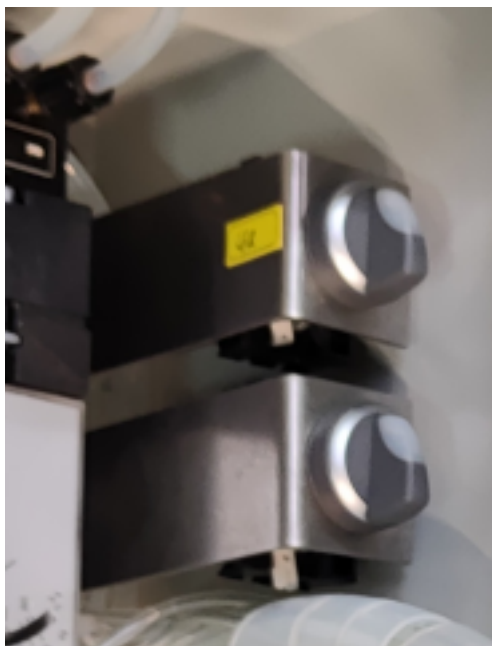

**Fig. 17:**  $W_{int}/W_{ext}$  switch

## 8 Malfunctions

### **i** Note

Contact SAMSON's After-sales Service for malfunctions not listed in the table.

The malfunctions listed in this chapter are caused by mechanical faults and incorrect sizing. In the simplest case, the functioning

can be restored following the recommended action. Special tools may be required to rectify the fault.

### **💡** Tip

SAMSON's After-sales Service can support you in drawing up an inspection and test plan for your plant.

### 8.1 Troubleshooting

Malfunction	Possible reasons	Recommended action
Air control system does not function (black indicator)	Supply pressure insufficient	⇒ Check supply pressure: 2 to 6 bar.
	Set point of the supply pressure regulator incorrect	⇒ Set the supply pressure regulator to 1.4 bar ±0.1 bar. ⇒ Contact SAMSON's After-sales Service if parts are damaged.
The air control system does not respond as required	The air control system is set to manual mode	⇒ Set the air control system to automatic mode (see Chapter 7.2.3).
	Direction of action for the controller module incorrectly set	⇒ Turn the turnboard for direction of action (see Chapter 6.2.4).
	Air output capacity insufficient	⇒ Set the turnboard to the large air output capacity (see Chapter 6.2.5).
		⇒ Reduce the volumes between the air control system and the control valve (shorter distance, smaller nominal size).
	Proportional-action coefficient <b>K<sub>p</sub></b> and reset time <b>T<sub>n</sub></b> not tuned to the process	⇒ Check the <b>K<sub>p</sub></b> and <b>T<sub>n</sub></b> settings at the controller module and, if necessary, change them (see Chapter 6.2.6 and Chapter 6.2.7).
	Filter in the controller module blocked	⇒ Remove filter and clean it (see Chapter 9.2.1).
	Hose connections leaking	⇒ Check the hose connection for leaks.
Controller module defective	⇒ Check the Type 3423 Controller Module (see Chapter 9). ⇒ Contact SAMSON's After-sales Service if parts are damaged.	
The set point <b>w</b> cannot be changed at the adjuster (in version with <b>w<sub>int</sub></b> / <b>w<sub>ext</sub></b> changeover)	Switch set to <b>w<sub>ext</sub></b>	⇒ Set the switch <b>w<sub>int</sub></b> / <b>w<sub>ext</sub></b> to <b>w<sub>int</sub></b> .
No set point feedback	Wrong analog signal (0 to 10 V) used for analysis	⇒ Make sure the correct signal (4 to 20 mA) is used (see Chapter 6.2.3).

### 8.2 Emergency action

Plant operators are responsible for emergency action to be taken in the plant.

In case of malfunction in the air control system:

1. Close the supply air line to depressurize the air control system.
2. Perform troubleshooting (see Chapter 8.1).
3. Rectify those malfunctions that can be remedied following the information given in this document. Contact SAMSON's After-sales Service in all other cases.

#### Putting the device back into operation after a malfunction

⇒ See Chapter 6.

## 9 Servicing

The air control system does not require much maintenance. Nevertheless, it is subject to natural wear, particularly the supply pressure regulators. Depending on the operating conditions, check the air control system at regular intervals to avoid possible malfunctions.

Check the air supply at regular intervals depending on the operating periods. To guarantee trouble-free operation of the device, make sure that the supply air is always clean.

Plant operators are responsible for drawing up an inspection and test plan. Details on faults and how to remedy them can be found in the Chapter 8.

The work described in this chapter is to be performed only by personnel appropriately qualified to carry out such tasks.

### NOTICE

#### **Risk of damage due to the use of unsuitable tools.**

Certain tools are required to work on the device.

⇒ Only use tools approved by SAMSON. When in doubt, consult SAMSON.

### Note

**The device was checked by SAMSON before it left the factory.**

- Certain test results certified by SAMSON lose their validity when the components in the air control system are opened. Such testing includes leak tests.
- The product warranty becomes void if service or repair work not described in these instructions is performed without prior agreement by SAMSON's After-sales Service.
- Only use original spare parts by SAMSON, which comply with the original specifications.

## 9.1 Service work preparations

1. Lay out the necessary material and tools to have them ready for the service work.
2. Put the air control system out of operation (see Chapter 8 and Chapter 10).

The following service work can be performed after preparation is completed:

- Adjust the set point of the supply pressure regulator (see Chapter 9.2.2).
- Retune the zero point of the controller module (see Chapter 9.2.3).
- Check the air filter and restriction (see Chapter 9.2.1).

## 9.2 Service work

- ⇒ Before performing any service work, preparations must be made to the air control system (see Chapter 9.1).
- ⇒ After all service work is completed, check the air control system before putting it back into operation (see Chapter 5.4).

### 9.2.1 Checking the air filter and restriction

Check the air filter and restriction installed in the upstream air reducing station regularly.

If the performance worsens, clean or replace the appropriate filters.

If a Type 3423 Controller Module does not control properly or the output signal is missing, unscrew the restriction with air filter in the controller module. It may be necessary to unscrew and clean the filter or to replace it (see Fig. 18, order no. 1390-0183).

In addition, all the ports have filters with plastic rims (order no. 0550-0189) on the connecting plate. These filters can be unscrewed and removed for cleaning.

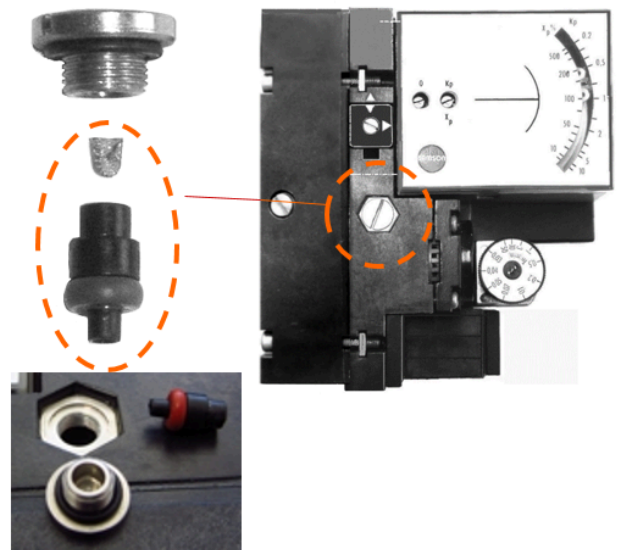

Fig. 18: Air filter and restriction in the Type 3423 Controller Module

### 9.2.2 Adjust the set point of the supply pressure regulator.

Proceed as follows:

1. Open the air control system (see Chapter 6.2.1).
2. Read the values off the pressure gauges of the supply pressure regulators 50R5/50R6. They must be set to **1.4 bar (+/- 0.1 bar)**.

#### Readings within the tolerance range:

3. No further action necessary **Proceed as described in step 5.**

#### Readings outside the tolerance range:

4. Use a screwdriver or box wrench (A/F 10) to adjust the supply pressure regulator to **1.4 bar (+/- 0.1 bar)** (see Fig. 20).
5. Start up the air control system (see Chapter 6).



Fig. 19: Setup inside the Type 7311 Air Control System  
 1 Supply pressure regulator for control loop 2 (50R6)  
 2 Supply pressure regulator for control loop 1 (50R5)



Fig. 20: Supply pressure regulator

### 9.2.3 Retuning the zero point of the controller module

If deviations arise between the controlled variable and set point during operation, the zero point can be retuned. Turn the zero adjuster (see Fig. 21) until the controlled variable and set point on the front display coincide.

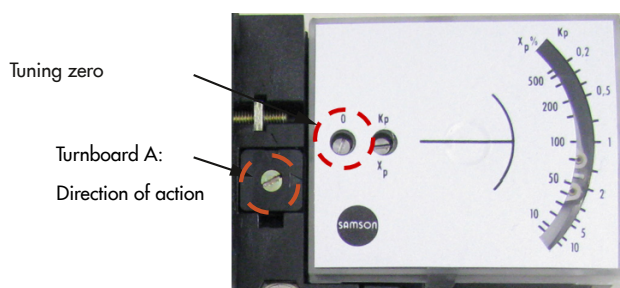

Fig. 21: Position of the turnboard A and zero adjustment

### 9.2.4 Putting the system back into operation after service work

#### ⚠ WARNING

**Danger due to hazardous conditions arising in the plant.**  
 Upon failure of the supply air in automatic mode and reconnecting the supply air, make sure that no hazardous conditions arise in the controlled process.  
 ⇒ Before reconnecting the supply air, check the condition of the controlled process.

#### 📌 NOTICE

**Risk of damage to the air control system due to excessively high upstream pressure.**  
 The installed supply pressure regulator has a maximum inlet pressure and a fixed set point adjustment.  
 ⇒ The maximum inlet pressure at the supply pressure regulator must not exceed 6 bar.  
 ⇒ The supply pressure regulator is set to 1.4 bar (+/- 0.1 bar) in the delivered state. A different setting is not permissible.

⇒ Put the air control system back into operation (see Chapter 6). Make sure the requirements and conditions for start-up or putting the device back into operation are met.

### 9.3 Ordering spare parts and operating supplies

Contact your nearest SAMSON subsidiary or SAMSON's After-sales Service for information on spare parts, lubricants and tools.

## 10 Decommissioning

The work described in this chapter is to be performed only by personnel appropriately qualified to carry out such tasks.

### **⚠ DANGER**

**Risk of personal injury due to the operating medium being released.**

When the unit is operated with nitrogen as the pneumatic supply, nitrogen is released to the atmosphere by the components. Released nitrogen displaces the oxygen in the surrounding air.

- ⇒ Before starting any work on the air control system, depressurize all plant sections and components affected.
- ⇒ Do not start up the air control system until all parts have been mounted.
- ⇒ When the unit is operated with nitrogen as the pneumatic supply: connect a leakage line and discharge the nitrogen to a safe environment (through the roof).
- ⇒ Wear personal protective equipment.

### **⚠ DANGER**

**Risk of bursting due to incorrect opening of pressurized equipment or components.**

- ⇒ Before starting any work on the air control system, depressurize all plant sections affected.
- ⇒ Wear personal protective equipment.

### **⚠ WARNING**

**Danger due to hazardous conditions arising in the plant.**

Upon failure of the supply air in automatic mode and reconnecting the supply air, make sure that no hazardous conditions arise in the controlled process.

- ⇒ Before reconnecting the supply air, check the condition of the controlled process.

### **⚠ WARNING**

**Risk of personal injury due to pressurized components and the operating medium being released.**

- ⇒ Do not unscrew the supply air line while the air control system is pressurized.
- ⇒ Do not start up the air control system until all parts have been mounted.
- ⇒ Wear goggles when working near the system. Follow the instructions given by the plant operator.

### **⚠ WARNING**

**Risk of hearing loss or deafness due to loud noise.**

The noise emissions depend on the version of the air control system, the plant facilities and process medium.

- ⇒ Wear hearing protection when working near the system. Follow the instructions given by the plant operator. Wear hearing protection when working near the system. Follow the instructions given by the plant operator.

To decommission the air control system before removing it, proceed as follows:

1. Shut off or disconnect the supply air line and signal lines.
2. Shut off or disconnect the external lines.
3. Depressurize the plant.

## 11 Removal

The work described in this chapter is to be performed only by personnel appropriately qualified to carry out such tasks.

Before removing the valve, make sure the following conditions are met:

- The air control system is put out of operation (see Chapter 10).

### 11.1 Removing the device

1. Remove all supply lines.
2. If applicable, remove all electrical wiring from the terminal block and pull them out of the cable entry.
3. Remove the air control system from the wall (see Chapter 4).

## 12 Repair

If the air control system does not function properly according to how it was originally sized or does not function at all, it is defective and must be repaired or exchanged.

---

**NOTICE**

***Risk of damage due to incorrect service or repair work.***

*Do not perform any repair work on your own.*

⇒ *Contact SAMSON's After-sales Service for service and repair work.*

---

### 12.1 Returning devices to SAMSON

Defective devices can be returned to SAMSON for repair.  
Proceed as follows to return devices to SAMSON:

1. Put the air control system out of operation (see Chapter 10).
2. Proceed as described on our website at  
▶ [www.samsongroup.com](http://www.samsongroup.com) > SERVICE > After-sales Service > Returning goods

## 13 Disposal



SAMSON is a registered producer.  
▶ [www.samsongroup.com](http://www.samsongroup.com) > About SAMSON > Environment, Social & Governance > Material Compliance > Waste electrical and electronic equipment (WEEE)  
WEEE reg. no.: DE 62194439

- ⇒ Observe local, national and international refuse regulations.
- ⇒ Do not dispose of components, lubricants and hazardous substances together with your other household waste.

---

**i Note**

*SAMSON can provide you with a recycling passport according to PAS 1049 on request. Simply e-mail us at [aftersaleservice@samsongroup.com](mailto:aftersaleservice@samsongroup.com) giving details of your company address.*

---

**💡 Tip**

*On request, SAMSON can appoint a service provider to dismantle and recycle the product as part of a distributor take-back scheme.*

---



## 14 Certificates

The following certificates are included on the next pages:

- EU declaration of conformity for Type 7311

# EU DECLARATION OF CONFORMITY

## TRANSLATION



This declaration of conformity is issued under the sole responsibility of the manufacturer.

For the following product

### **Type 7311 Air Control System**

the conformity with the relevant Union harmonisation legislation is declared with:

For version...	EU directive	Harmonised standard
All versions	RoHS 2011/65/EU 2015/863/EU	EN IEC 63000:2018
With electric pressure transmitter	EMC 2014/30/EU	EN 61326-1:2013 EN 61326-2-3:2013

Manufacturer:

**SAMSON AKTIENGESELLSCHAFT**  
Weismüllerstraße 3  
D-60314 Frankfurt/Main  
Germany

Frankfurt/Main, 10. Juli 2024

A handwritten signature in blue ink, appearing to read "ppa. F. Schulz", written over a horizontal line.

ppa. Friedrich Schulz  
Director Modular Systems & Solutions

## 15 Appendix

### 15.1 Tightening torques

Table 3: Tightening torques

Part	Width across flats	Tightening torque in Nm
Pneumatic connections	A/F 17 (8 mm pipe)	22
	A/F 32 (18 mm pipe)	90
Cable duct	A/F 24	5

### 15.2 Tools

SAMSON's After-sales Service can support you concerning tools approved by SAMSON.

### 15.3 Accessories

The optional Type 7491 Pressure Transmitter is used to transmit the set point adjusted in the air control system as a 4 to 20 mA signal, for example to a control room.

A pressure transmitter is required for each control loop.

When one or two pressure transmitters are used, a terminal block and cable duct are installed for each pressure transmitter.

Fig. 22 shows the location and set-up of the accessories.

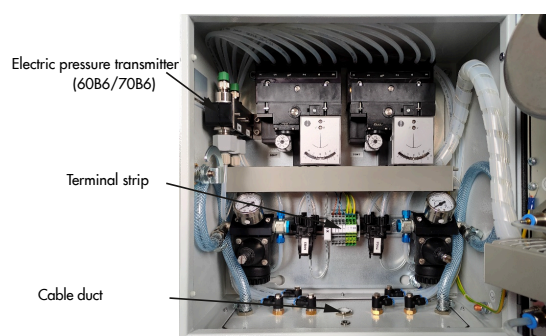

Fig. 22: Accessories (electric pressure transmitter)

### 15.4 Spare parts

Contact your nearest SAMSON subsidiary or SAMSON's After-sales Service for information on spare parts, lubricants and tools.

## 15.5 After-sales service

Contact SAMSON's After-sales Service for support concerning service or repair work or when malfunctions or defects arise.

### E-mail contact

You can reach our after-sales service at ► [aftersaleservice@samsongroup.com](mailto:aftersaleservice@samsongroup.com).

### Addresses of SAMSON AG and its subsidiaries

The addresses of SAMSON AG, its subsidiaries, representatives and service facilities worldwide can be found on our website (► [www.samsongroup.com](http://www.samsongroup.com)) or in SAMSON product catalogs.

### Required specifications

Please submit the following details:

- Device type and nominal size
- Model number or material number
- Installation drawing with all the additionally installed components









SAMSON AKTIENGESELLSCHAFT  
Weismüllerstraße 3 · 60314 Frankfurt am Main, Germany  
Phone: +49 69 4009-0 · Fax: +49 69 4009-1507  
samson@samsongroup.com · www.samsongroup.com