

MOUNTING AND OPERATING INSTRUCTIONS



EB 5868-1 EN

Translation of original instructions



Type 3214/3374 · Type 3214 Globe Valve balanced by a diaphragm

Types 3214/3374 and 3214/SAM Electric Control Valves Type 3214 Globe Valve balanced by a diaphragm

Edition December 2023



Note on these mounting and operating instructions

These mounting and operating instructions assist you in mounting and operating the device safely. The instructions are binding for handling SAMSON devices. The images shown in these instructions are for illustration purposes only. The actual product may vary.

- For the safe and proper use of these instructions, read them carefully and keep them for later reference.
- If you have any questions about these instructions, contact SAMSON's After-sales Service (aftersaleservice@samsongroup.com).



Documents relating to the device, such as the mounting and operating instructions, are available on our website at www.samsongroup.com > **Downloads > Documentation.**

Definition of signal words

DANGER

Hazardous situations which, if not avoided, will result in death or serious injury

WARNING

Hazardous situations which, if not avoided, could result in death or serious injury

NOTICE

Property damage message or malfunction

Note

Additional information

Tip

Recommended action

1	Safety instructions and measures	1-1
1.1	Notes on possible severe personal injury	1-4
1.2	Notes on possible personal injury	1-5
1.3	Notes on possible property damage	1-6
2	Markings on the device	2-1
2.1	Valve nameplate	2-1
2.2	Actuator nameplate	2-1
3	Design and principle of operation	3-1
3.1	Fail-safe action	3-1
3.2	Versions	3-3
3.3	Additional fittings	3-4
3.4	Technical data	3-4
4	Shipment and on-site transport	4-1
4.1	Accepting the delivered goods	4-1
4.2	Removing the packaging from the valve	4-1
4.3	Transporting and lifting the valve	4-1
4.3.1	Transporting the valve	4-2
4.3.2	Lifting the valve	4-2
4.4	Storing the valve	4-4
5	Installation	5-1
5.1	Installation conditions	5-1
5.2	Preparation for installation	5-2
5.3	Installing the device	5-3
5.3.1	Installing the control valve into the pipeline	5-3
5.3.2	Mounting actuators	5-4
5.3.3	Connecting the actuator	5-4
5.3.4	Configuring the actuator	5-4
5.4	Testing the installed valve	5-6
5.4.1	Leak test	5-7
5.4.2	Travel motion	5-7
5.4.3	Fail-safe action	5-7
5.4.4	Pressure test	5-7
6	Start-up	6-1
7	Operation	7-1

Contents

8	Malfunctions	8-1
8.1	Troubleshooting	8-1
8.2	Emergency action	8-2
9	Servicing	9-1
10	Decommissioning	10-1
11	Removal	11-1
11.1	Removing the valve from the pipeline.....	11-1
11.2	Removing the actuator from the valve	11-1
12	Repairs	12-1
12.1	Returning devices to SAMSON	12-1
13	Disposal	13-1
14	Certificates	14-1
15	Annex	15-1
15.1	After-sales service	15-1

1 Safety instructions and measures

Intended use

The SAMSON Type 3214 Valve balanced by a diaphragm is designed for use in temperature control circuits in HVAC plants. The valve is primarily combined with the following SAMSON actuators to form an electric control valve:

- Type 3374 Electric Actuator
- Type 3376 Electric Actuator ¹⁾
- Type SAM Electric Actuator

The valve with its actuator is designed to operate under exactly defined conditions (e.g. operating pressure, process medium, temperature). Therefore, operators must ensure that the control valve is only used in operating conditions that meet the specifications used for sizing the valve at the ordering stage. In case operators intend to use the control valve in applications or conditions other than those specified, contact SAMSON.

SAMSON does not assume any liability for damage resulting from the failure to use the device for its intended purpose or for damage caused by external forces or any other external factors.

➔ Refer to the technical data and nameplate for limits and fields of application as well as possible uses.

Reasonably foreseeable misuse

The control valve is not suitable for the following applications:

- Use outside the limits defined during sizing and by the technical data

Furthermore, the following activities do not comply with the intended use:

- Use of non-original spare parts
- Performing service and repair work not described

Qualifications of operating personnel

The control valve must be mounted, started up, serviced and repaired by fully trained and qualified personnel only; the accepted industry codes and practices must be observed. According to these mounting and operating instructions, trained personnel refers to individuals who are able to judge the work they are assigned to and recognize possible hazards due to their specialized training, their knowledge and experience as well as their knowledge of the applicable standards.

¹⁾ Product in preparation

Safety instructions and measures

Personal protective equipment

We recommend wearing the following protective equipment:

- Protective clothing, safety gloves and eye protection in applications with hot or cold media

→ Check with the plant operator for details on further protective equipment.

Revisions and other modifications

Revisions, conversions or other modifications of the product are not authorized by SAMSON. They are performed at the user's own risk and may lead to safety hazards, for example. Furthermore, the product may no longer meet the requirements for its intended use.

Safety features

In combination with the Type 3374-21 and Type 3374-27 Actuators, the following safety feature exists: upon failure of the supply voltage, the valve moves to a defined fail-safe position (see the 'Design and principle of operation' section). The direction of action of the fail-safe action is defined by the actuator version (see associated actuator documentation).

Warning against residual hazards

To avoid personal injury or property damage, plant operators and operating personnel must prevent hazards that could be caused in the control valve by the process medium, the operating pressure, the signal pressure or by moving parts by taking appropriate precautions. Plant operators and operating personnel must observe all hazard statements, warnings and caution notes in these mounting and operating instructions.

Hazards resulting from the special working conditions at the installation site of the valve must be identified in a risk assessment and prevented through the corresponding safety instructions drawn up by the operator.

Responsibilities of the operator

Operators are responsible for proper use and compliance with the safety regulations. Operators are obliged to provide these mounting and operating instructions as well as the referenced documents to the operating personnel and to instruct them in proper operation. Furthermore, operators must ensure that operating personnel or third parties are not exposed to any danger.

Operators are additionally responsible for ensuring that the limits for the product defined in the technical data are observed. This also applies to the start-up and shutdown procedures. Start-up and shutdown procedures fall within the scope of the operator's duties and, as such, are not part of these mounting and operating instructions. SAMSON is unable to make any statements about these procedures since the operative details (e.g. differential pressures and temperatures) vary in each individual case and are only known to the operator.

Responsibilities of operating personnel

Operating personnel must read and understand these mounting and operating instructions as well as the referenced documents and observe the specified hazard statements, warnings and caution notes. Furthermore, operating personnel must be familiar with the applicable health, safety and accident prevention regulations and comply with them.

Referenced standards, directives and regulations

The control valves comply with the requirements of the European Pressure Equipment Directive 2014/68/EU and the Machinery Directive 2006/42/EC. Valves with a CE marking have a declaration of conformity which includes information about the applied conformity assessment procedure. The 'Certificates' section contains this declaration of conformity.

The electric actuators are designed for use in low voltage installations. For wiring, maintenance and repair, observe the relevant safety regulations.

Referenced documentation

The following documents apply in addition to these mounting and operating instructions:

- Mounting and operating instructions for mounted actuator, e.g. SAMSON actuators:
 - ▶ EB 8331-X for Type 3374
 - ▶ EB 8330 for Type SAM
 - ▶ EB 8333-X for Type 3376 ¹⁾

¹⁾ Product in preparation

1.1 Notes on possible severe personal injury

DANGER

Risk of bursting in pressure equipment.

Valves and pipelines are pressure equipment. Impermissible pressure or improper opening can lead to valve components bursting.

- Observe the maximum permissible pressure for valve and plant.
- Before starting any work on the control valve, depressurize all plant sections affected as well as the valve.
- Drain the process medium from the plant sections affected as well as from the valve.

Risk of fatal injury due to electric shock.

- Do not remove any covers to perform adjustment work on live parts.
- Before performing any work on the device and before opening the device, disconnect the supply voltage and protect it against unintentional reconnection.
- Only use power interruption devices that are protected against unintentional reconnection of the power supply.

1.2 Notes on possible personal injury

WARNING

Crush hazard arising from moving parts.

The control valves contain moving parts (actuator and plug stem), which can injure hands or fingers if inserted into the valve.

- Do not insert hands or finger into the yoke while the supply voltage is connected to the actuator.
- Disconnect and lock the supply voltage before performing any work on the control valve.
- Do not impede the movement of the actuator and plug stem by inserting objects into the yoke.
- Before unblocking the actuator and plug stem after they have become blocked (e.g. due to seizing up after remaining in the same position for a long time), release any stored energy in the actuator.

Risk of personal injury due to residual process medium in the valve.

While working on the valve, residual medium can flow out of the valve and, depending on its properties, cause personal injury, e.g. (chemical) burns.

- If possible, drain the process medium from the plant sections affected and from the valve.
- Wear protective clothing, safety gloves and eye protection.

Risk of burn injuries due to hot components and pipelines.

Depending on the process medium, valve components and pipelines may get very hot and cause burn injuries.

- Allow components and pipelines to cool down.
- Wear protective clothing and safety gloves.

Risk of hearing loss or deafness due to loud noise.

The noise emissions depend on the valve version, plant facilities and process medium.

- Wear hearing protection when working near the valve.

WARNING

Risk of personal injury due to incorrect operation, use or installation as a result of information on the valve being illegible.

Over time, markings, labels and nameplates on the valve may become covered with dirt or become illegible in some other way. As a result, hazards may go unnoticed and the necessary instructions not followed. There is a risk of personal injury.

- Keep all relevant markings and inscriptions on the device in a constantly legible state.
- Immediately renew damaged, missing or incorrect nameplates or labels.

1.3 Notes on possible property damage

NOTICE

Risk of damage to the electric control valve due to the supply voltage exceeding the permissible tolerances.

The electric control valves are designed for use according to regulations for low-voltage installations.

- Observe the permissible tolerances of the supply voltage. See associated actuator documentation.

Risk of valve damage due to contamination (e.g. solid particles) in the pipeline.

The plant operator is responsible for cleaning the pipelines in the plant.

- Flush the pipelines before start-up.

Risk of valve damage due to unsuitable medium properties.

The valve is designed for a process medium with defined properties.

- Only use the process medium specified for sizing the equipment.

2 Markings on the device

The nameplate shown was up to date at the time of publication of this document. The nameplate on the device may differ from the one shown.

2.1 Valve nameplate

It includes all details required to identify the device:

- 1 Type
- 2 Certificate number/TÜV registration no.
- 3 Configuration ID
- 4 Production order number
- 5 K_{vs} coefficient
- 6 Set point range/spring force
- 7 Valve size
- 8 Pressure rating
- 9 Perm. differential pressure
- 10 Permissible temperature
- 11 Body material



Tip

We recommend to include the device's configuration ID (item 3 on the nameplate) and/or its material number (as specified in the order confirmation) in the plant documentation for the associated tag number.

For example, you can use the associated information to order a new nameplate from our After-sales Service, if required.

2.2 Actuator nameplate

See associated actuator documentation.

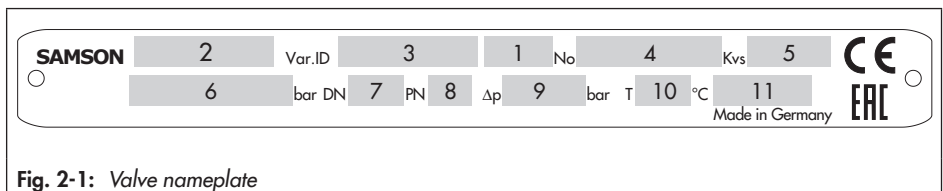

Fig. 2-1: Valve nameplate

3 Design and principle of operation

The control valves consist of the Type 3214 Globe Valve balanced by a diaphragm and an electric actuator. The medium flows through the valves in the direction indicated by the arrow on the valve body. The cross-sectional area of flow between the seat (2) and plug (3) is determined by the position of the plug stem (6).

The downstream pressure p_2 is applied to the inside of the valve; the upstream pressure p_1 acts on the outside. The forces acting on the valve plug due to the upstream and downstream pressures are balanced by the diaphragm (4).

The plug is moved by changing the control signal applied to the actuator. For the Type 3374 and Type SAM Electric Actuators, this signal is a three-step signal.

3.1 Fail-safe action

When the Type 3214 Valve is combined with one of the following actuators, the valve moves to the fail-safe position up upon failure of the supply voltage:

- Type 3374-21 and Type 3374-27 Electric Actuators

Fail-safe action

A safety mechanism in the actuator is triggered when the supply voltage fails or the control signal is interrupted by the limitation equipment due to the temperature or pressure exceeding the adjusted limit. The actuator stem is moved by the force of the compression springs in the actuator. One of two different fail-safe positions can be assumed by the control valve:

- **Actuator stem extends:** if fail-action is triggered, the actuator stem extends and closes the valve.
- **Actuator stem retracts:** if fail-action is triggered, the actuator stem retracts and opens the valve.

i Note

The fail-safe action of electric actuators is already determined at the ordering stage.

Design and principle of operation

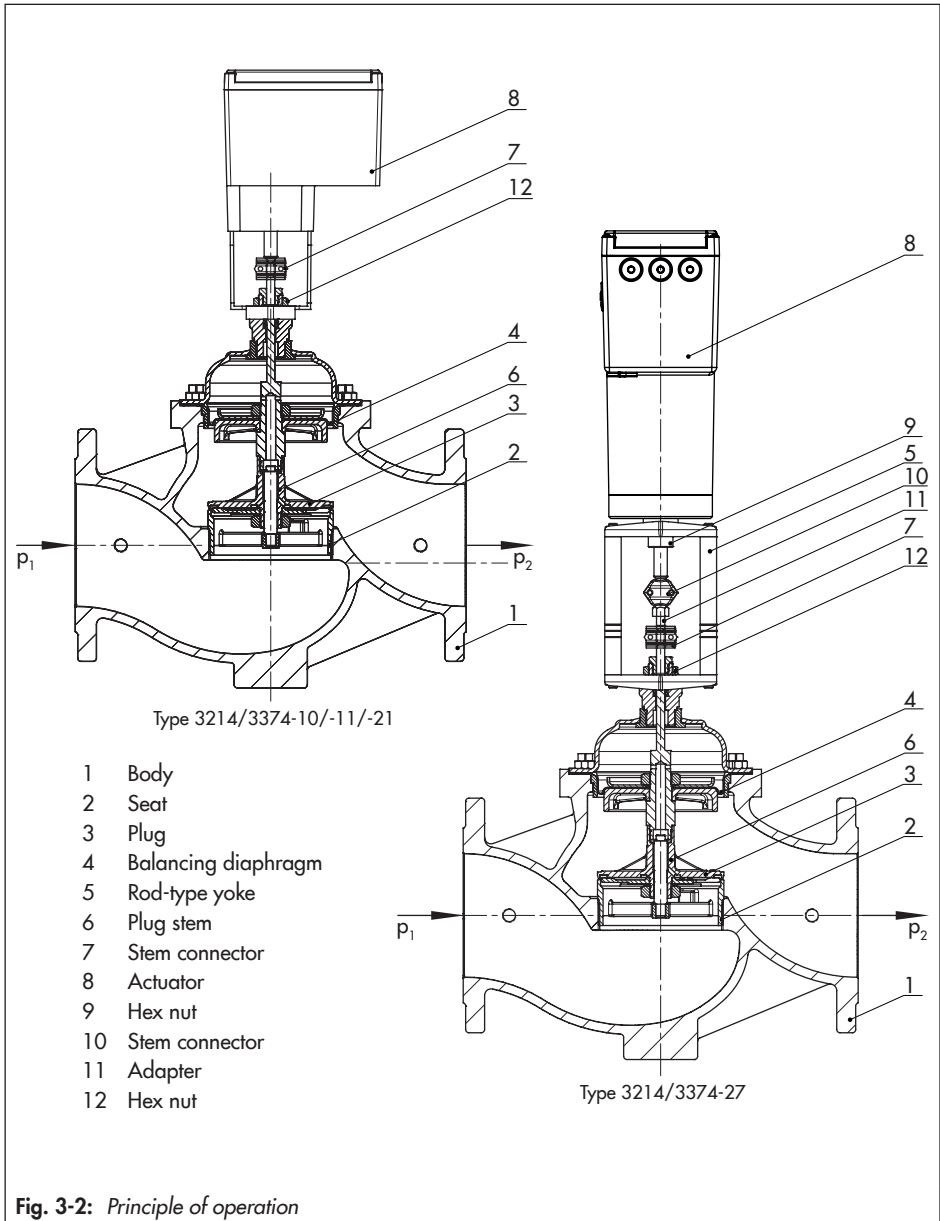

3.2 Versions

Electric actuators

The Type 3374 and Type SAM Electric Actuators are controlled using a three-step signal as standard.

The Type 3374 and Type SAM Actuators can also be controlled in the versions with positioner by a 0/4 to 20 mA or 0/2 to 10 V signal. Various electrical accessories can be optionally installed.

Types 3374-21 and 3374-27 Actuators are able to perform a fail-safe action (see section Table 3-1).

Testing according to DIN EN 14597



The Type 3374-21 and Type 3374-27 with "actuator stem extends" fail-safe action are in conjunction with the Type 3214 Valves tested by the German technical surveillance association TÜV according to DIN EN 14597.

The registration number is available on request.

Table 3-1: Available versions and possible combinations (Type 3214 Valve/actuator)

Actuator	Type	Valve size							
		65	80	100	125	150	200	250	300
Without fail-safe action	3374-10	–	–	–	•	•	•	•	–
	3374-11	•	•	•	–	–	–	–	–
	SAM-32	–	–	–	–	–	–	–	•
With fail-safe action	3374-27	–	–	–	•	•	•	•	–
	3374-21	•	•	•	–	–	–	–	–
	3376 ²⁾	–	–	–	–	–	–	–	•

¹⁾ The rod-type yoke (1400-8822) is additionally required to connect Type 3374-27 Actuators.

²⁾ Product in preparation

3.3 Additional fittings

Refer to the instructions in the 'Installation' section.

Strainers

We recommend installing a SAMSON Type 2 NI Strainer upstream of the valve. It prevents solid particles in the process medium from damaging the valve.

Bypass and shut-off valves

We recommend installing a shut-off valve both upstream of the strainer and downstream of the valve and installing a bypass line. The bypass ensures that the plant does not need to be shut down for service and repair work on the valve.

Insulation of cold systems

Control valves can be insulated to reduce heat energy transfer.

The insulation thickness depends on the medium temperature and the ambient conditions. 50 mm is a typical thickness.

Noise reduction

The Type 3214 Globe Valve can be fitted with a flow divider ST 1. Refer to Data Sheet ► T 8081.

Safety guard

For operating conditions that require increased safety (e.g. in cases where the valve is freely accessible to untrained staff), a safety guard must be installed on control valves with a yoke to rule out a crush hazard arising from moving parts (actuator and plug stem). Plant operators are responsible for de-

termining whether a guard is to be used. The decision is based on the risk posed by the plant and its operating conditions.

3.4 Technical data

The nameplates on the valve and actuator provide information on the control valve version. See the 'Markings on the device' section and the associated actuator documentation.

i Note

More information is available in Data Sheet ► T 5868-1.

Noise emissions

SAMSON is unable to make general statements about noise emissions. The noise emissions depend on the valve version, plant facilities and process medium.

Table 3-2: Technical data · Type 3214 Globe Valve balanced by a diaphragm

Valve size	DN	65	80	100	125	150	200	250	300
Pressure rating	PN	16 and 25			16 to 40				
Rated travel	mm	15	15	15	30	30	30	30	50
K_{VS} coefficient		50	80	125	230	340	620	750	1200
Max. perm. differential pressure Δp	bar	10	10	10	12	12	10	10	10
Max. permissible temperature	°C								
Version for water		150							
Version for non-flammable gases		80							
Rangeability		40:1			30:1				
Leakage class according to IEC 60534-3		IV (≤ 0.01 % of K_{VS} coefficient)							
Conformity									

Table 3-3: Materials · Type 3214 Globe Valve balanced by a diaphragm

Material numbers according to DIN EN

Valve size	DN	65	80	100	125	150	200	250	300
Body	PN 16	EN-GJL-250 ¹⁾ EN-GJS-400-18-LT ²⁾			EN-GJL-250 ¹⁾	EN-GJL-250 ¹⁾	EN-GJL-250 ¹⁾ 1.0619		
	PN 16/25				EN-GJS-400-18-LT ²⁾	-			
	PN 16, 25 and 40				1.0619	1.0619			
Valve seat		1.4408		CC499K			1.4301		
Plug		CW617N with EPDM soft seal			CC491K with EPDM soft seal			1.4301 with EPDM soft seal	
Pressure balancing		EPDM balancing diaphragm							

¹⁾ Formerly EN-JL1040

²⁾ Formerly EN-JL1049

Design and principle of operation

Table 3-4: *Dimensions and weights · Dimensions in mm · Weights in kg*

The lengths and heights in the dimensional drawings are shown on pages 3-7 and 3-8.

Valve size	DN	65	80	100	125	150	200	250	300
L	mm	290	310	350	400	480	600	730	850
H1	mm	163	163	189	286	291	361	361	386
H2	mm	98	98	118	145	175	270	270	285
H in mm	Type 3214/3374-27	–	–	–	753	778	848	848	–
	Type 3214/3374-10/-11/-21	457	457	483	580	585	655	655	–
	Type 3214/SAM-32	–	–	–	–	–	–	–	1130
	Type 3214/3376 ²⁾	–	–	–	–	–	–	–	On request
Weight ¹⁾	kg (approx.)								
Type 3214/3374-27		–	–	–	56	76	218	228	–
Type 3214/3374-10/-11/-21		30	34	44	52	72	214	224	–
Type 3214/SAM-32		–	–	–	–	–	–	–	335

¹⁾ Valves in PN 16; versions in PN 25 and 40: +15 %

²⁾ Product in preparation

Dimensional drawings

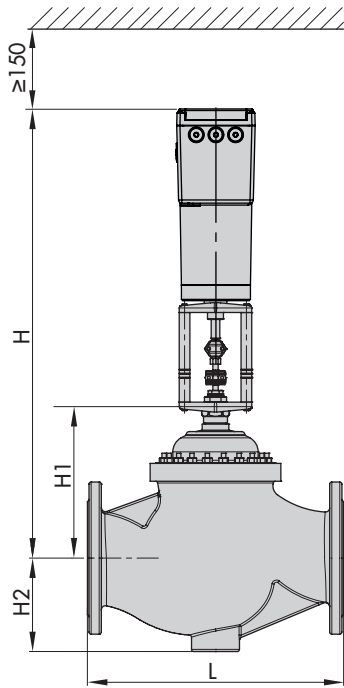

Type 3214/3274-27

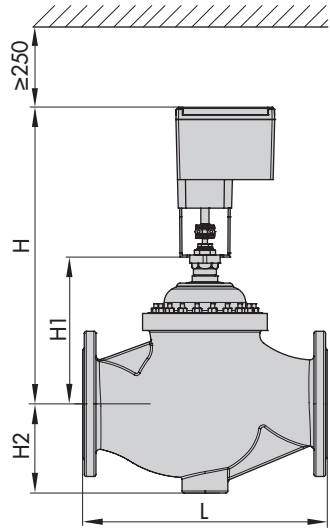

Type 3214/3374-10/-11/-21

Dimensional drawings

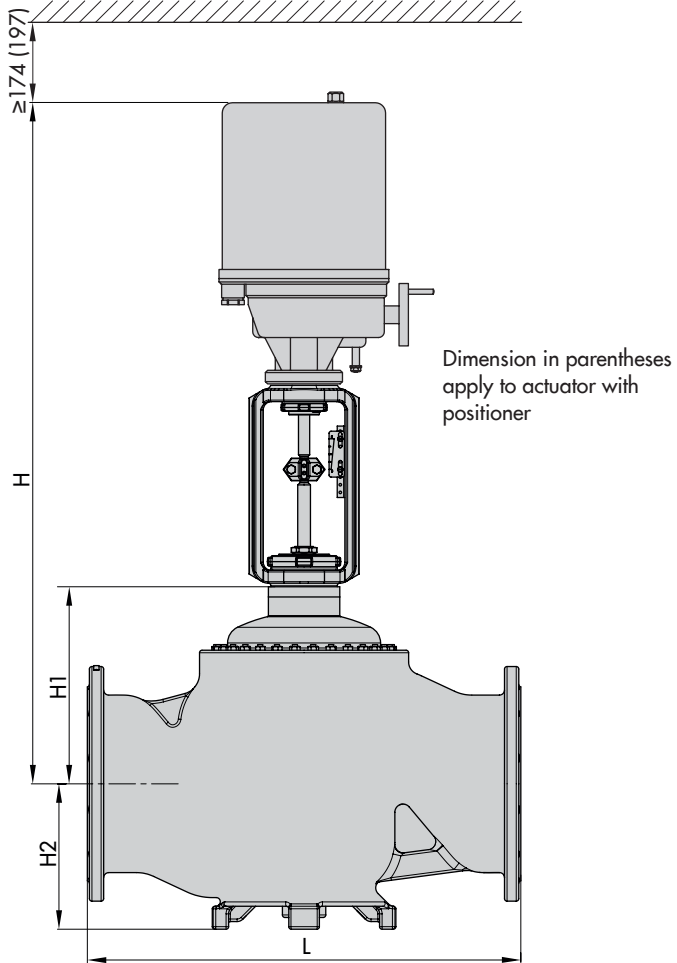

Type 3214/SAM-32

4 Shipment and on-site transport

The work described in this section is to be performed only by personnel appropriately qualified to carry out such tasks.

4.1 Accepting the delivered goods

After receiving the shipment, proceed as follows:

1. Check the scope of delivery. Check that the specifications on the valve nameplate match the specifications in the delivery note. See the 'Markings on the device' section for nameplate details.
2. Check the shipment for transportation damage. Report any damage to SAMSON and the forwarding agent (refer to delivery note).
3. Determine the weight and dimensions of the units to be lifted and transported in order to select the appropriate lifting equipment and lifting accessories. Refer to the transport documents and the 'Technical data' section.

4.2 Removing the packaging from the valve

Observe the following sequence:

- Do not remove the packaging until immediately before installation.
- Leave the control valve in its transport container or on the pallet to transport it on site.

- Do not remove the protective caps from the inlet and outlet until immediately before installing the valve into the pipeline. They prevent foreign particles from entering the valve.
- Dispose and recycle the packaging in accordance with the local regulations.

4.3 Transporting and lifting the valve

⚠ DANGER

Danger due to suspended loads falling.

- *Stay clear of suspended or moving loads.*
 - *Close off and secure the transport paths.*
-

⚠ WARNING

Risk of lifting equipment tipping over and risk of damage to lifting accessories due to exceeding the rated lifting capacity.

- *Only use approved lifting equipment and accessories whose minimum lifting capacity is higher than the weight of the valve (including actuator and packaging, if applicable).*
-

⚠ WARNING

Risk of personal injury due to the control valve tipping over.

- *Observe the valve's center of gravity.*
 - *Secure the valve against tipping over or turning.*
-

WARNING

Risk of injury due to incorrect lifting without the use of lifting equipment.

Lifting the control valve without the use of lifting equipment may lead to injuries (back injury in particular) depending on the weight of the control valve.

→ Observe the occupational health and safety regulations valid in the country of use.

NOTICE

Risk of valve damage due to incorrectly attached slings.

→ When lifting the control valve, make sure that the slings attached to the valve body bear the entire load.

→ Observe lifting instructions (see section 4.3.2).

Tip

Our after-sales service can provide more detailed transport and lifting instructions on request.

4.3.1 Transporting the valve

The control valve can be transported using lifting equipment (e.g. crane or forklift).

- Leave the control valve in its transport container or on the pallet to transport it.
- Observe the transport instructions.

Transport instructions

- Protect the control valve against external influences (e.g. impact).
- Do not damage the corrosion protection (paint, surface coatings). Repair any damage immediately.
- Protect the piping and any mounted valve accessories against damage.
- Protect the control valve against moisture and dirt.
- The permissible transportation temperature is between -20 and $+65$ °C.

4.3.2 Lifting the valve

To install a large valve into the pipeline, use lifting equipment (e.g. crane or forklift) to lift it.

Lifting instructions

- Use a hook with safety latch (see Fig. 4-1) to secure the slings from slipping off the hook during lifting and transporting.
- Secure slings against slipping.
- Make sure the slings can be removed from the valve once it has been installed into the pipeline.
- Prevent the control valve from tilting or tipping over.
- Do not leave loads suspended when interrupting work for longer periods of time.
- Make sure that the axis of the pipeline is always horizontal during lifting and the axis of the plug stem is always vertical.

- Make sure that the additional sling between the yoke and rigging equipment (hook, shackle etc.) does not bear any load when lifting valves. The sling only protects the control valve from tilting while being lifted. Before lifting the control valve, tighten the sling.

Lifting the control valve

1. Attach one sling to each flange of the body and to the rigging equipment (e.g. hook) of the crane or forklift (see Fig. 4-1).
2. If necessary, attach another sling to the valve yoke and to the rigging equipment. Make sure that the actuator stem is not damaged.
3. Carefully lift the control valve. Check whether the lifting equipment and accessories can bear the weight.
4. Move the control valve at an even pace to the site of installation.
5. Install the valve into the pipeline (see the 'Installation' section).
6. After installation in the pipeline, check whether the flanges are bolted tight and the valve in the pipeline holds.
7. Remove slings.

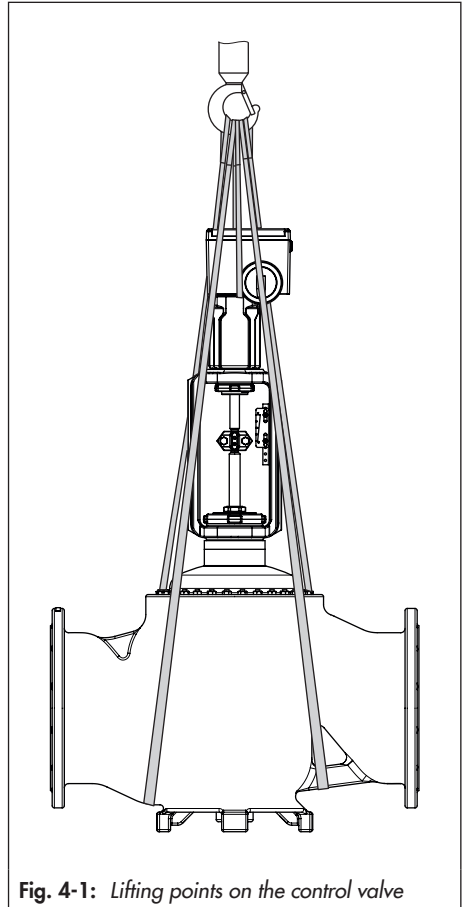

Fig. 4-1: Lifting points on the control valve

4.4 Storing the valve

NOTICE

Risk of valve damage due to improper storage.

- *Observe the storage instructions.*
 - *Avoid long storage times.*
 - *Contact SAMSON in case of different storage conditions or longer storage times.*
-

Note

We recommend to regularly check the control valve and the prevailing storage conditions during long storage periods.

Storage instructions

- The control valves can be stored horizontally. For storage periods longer than 4 months, we recommend storing the control valves in valve sizes DN 150 or larger upright with the actuator on top. Secure the valve in the stored position against slipping or tipping over.
- Protect the control valve against external influences (e.g. impact).
- Do not damage the corrosion protection (paint, surface coatings). Repair any damage immediately.
- Protect the control valve against moisture and dirt. Store it at a relative humidity of less than 75 %. In damp spaces, prevent condensation. If necessary, use a drying agent or heating.

- Make sure that the ambient air is free of acids or other corrosive media.
 - The permissible storage temperature is between -20 and $+65$ °C.
 - Do not place any objects on the control valve.
-

Tip

Our after-sales service can provide more detailed storage instructions on request.

5 Installation

The work described in this section is to be performed only by personnel appropriately qualified to carry out such tasks.

5.1 Installation conditions

Work position

The work position for the control valve is the front view looking onto the operating controls (including valve accessories).

Plant operators must ensure that, after installation of the device, the operating personnel can perform all necessary work safely and easily access the device from the work position.

Mounting position

Generally, we recommend installing the valve with the actuator upright and on top of the valve.

→ Contact SAMSON if the mounting position is not as specified above.

For versions with electric actuators, the actuator must not be suspended downwards (see Fig. 5-1).

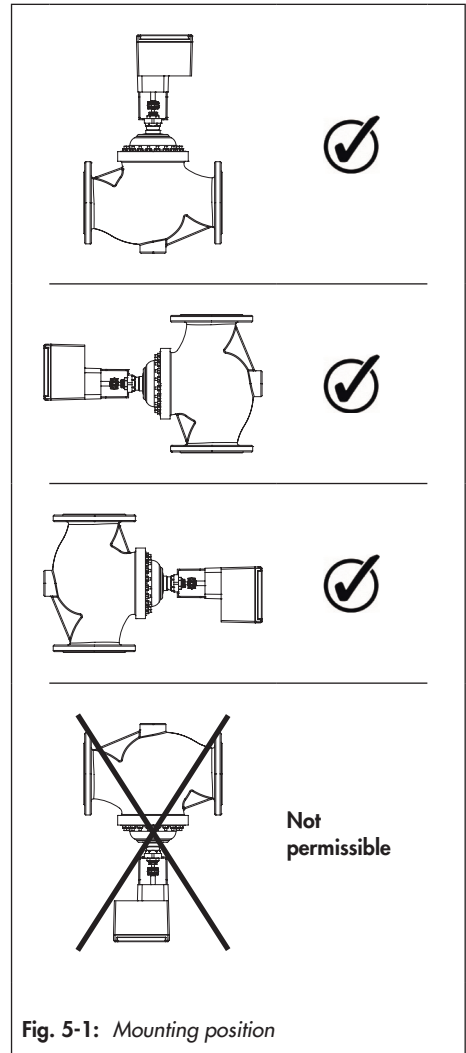

Fig. 5-1: Mounting position

Installation

Pipeline routing

To ensure that the valve functions properly, proceed as follows:

- Do not exceed the maximum permissible flow velocity.

i Note

The plant operator is responsible for determining the maximum permissible flow velocity. Our after-sales service can support you to determine the flow velocity for your plant.

- Install the valve free of stress and with the least amount of vibrations as possible. Read information under “Mounting position” and “Support or suspension” in this section.
- Install the valve allowing sufficient space to remove the actuator and valve or to perform service work on them.

Support or suspension

i Note

The plant engineering company is responsible for selecting and implementing a suitable support or suspension of the installed control valve and the pipeline.

Depending on the valve version and mounting position, the valve, actuator and pipeline must be supported or suspended.

5.2 Preparation for installation

Before installation, make sure the following conditions are met:

- The valve is clean.
- The valve and all valve accessories (including piping) are not damaged.
- The valve data on the nameplate (type designation, valve size, material, pressure rating and temperature range) match the plant conditions (size and pressure rating of the pipeline, medium temperature etc.). See the 'Markings on the device' section for nameplate details.
- The requested or required additional pipe fittings (see the 'Additional fittings' section) have been installed or prepared as necessary before installing the valve.

Proceed as follows:

- Lay out the necessary material and tools to have them ready during installation work.
- Flush the pipelines.

i Note

The plant operator is responsible for cleaning the pipelines in the plant.

- For steam applications, dry the pipelines. Moisture will damage the inside of the valve.
- Check any mounted pressure gauges to make sure they function properly.
- When the valve and actuator are already assembled, check the bolted joints. Components may loosen during transport.

5.3 Mounting the device

The activities listed below are necessary to install the valve and before it can be started up.

We recommend first installing the valve into the pipeline and mounting the actuator afterwards.

NOTICE

Risk of valve damage due to excessively high or low tightening torques.

→ Observe the specified torques when tightening control valve components. Excessive tightening torques lead to parts wearing out more quickly. Parts that are too loose may cause leakage.

5.3.1 Installing the control valve into the pipeline

1. Close the shut-off valves in the pipeline at the inlet and outlet of the plant section while the valve is being installed.
2. Prepare the relevant section of the pipeline for installing the valve.

Strainer:

- Make sure the direction of flow of the strainer and valve are identical.
 - Install the strainer with the filter element facing downwards.
 - Allow sufficient space to remove the filter.
3. Remove the protective caps from the valve ports before installing the valve.

4. Lift the valve using suitable lifting equipment to the site of installation (see the 'Lifting the valve' section). Observe the flow direction through the valve. The arrow on the valve indicates the direction of flow.
5. Make sure that the correct flange gaskets are used.
6. Bolt the pipe to the valve free of stress.
7. Attach a support or suspension on the valve, if necessary.

Insulation of cold systems

To insulate cold systems, we recommend to proceed as follows:

1. Fill the plant and carefully rinse it.
2. Shut down the plant and let it heat up until all the condensation water has dried off.

Observe the following on installing the control valve:

- Make sure that the electric actuator remains accessible after installation.
- Make sure that the plug stem can move freely and does not touch the insulation.
- Make sure that the actuator stem does not touch the insulation.

Note

The insulation thickness depends on the medium temperature and the ambient conditions. 50 mm is a typical thickness.

5.3.2 Mounting actuators

Mount the actuators as described in the associated actuator documentation:

- Type 3374 Electric Actuator
▶ EB 8331-X
- Type SAM Electric Actuator ▶ EB 8330

Type 3214 Valve with Type 3374-27 Actuator

A rod-type yoke (1400-8822) is required to mount the Type 3374-27 Actuator on the Type 3214 Valve.

1. Place the rod-type yoke (5) onto the body (1).
2. Tighten the hex nut (12) on the rod-type yoke (5) applying a tightening torque of at least 100 Nm.
3. Fasten adapter (11) together with the two stem connector clamps (7) to the plug stem (6). Observe further details and instructions in ▶ EB 8331-X.

5.3.3 Connecting the actuator

Perform the electrical connection of the actuator as described in the associated actuator documentation.

5.3.4 Configuring the actuator

The electric actuator versions with positioner can be adapted to the control task.

Configure the actuator as described in the associated actuator documentation.

i Note

For electric control valves with positioner, an initialization needs to be performed after the initial start-up (see associated documentation).

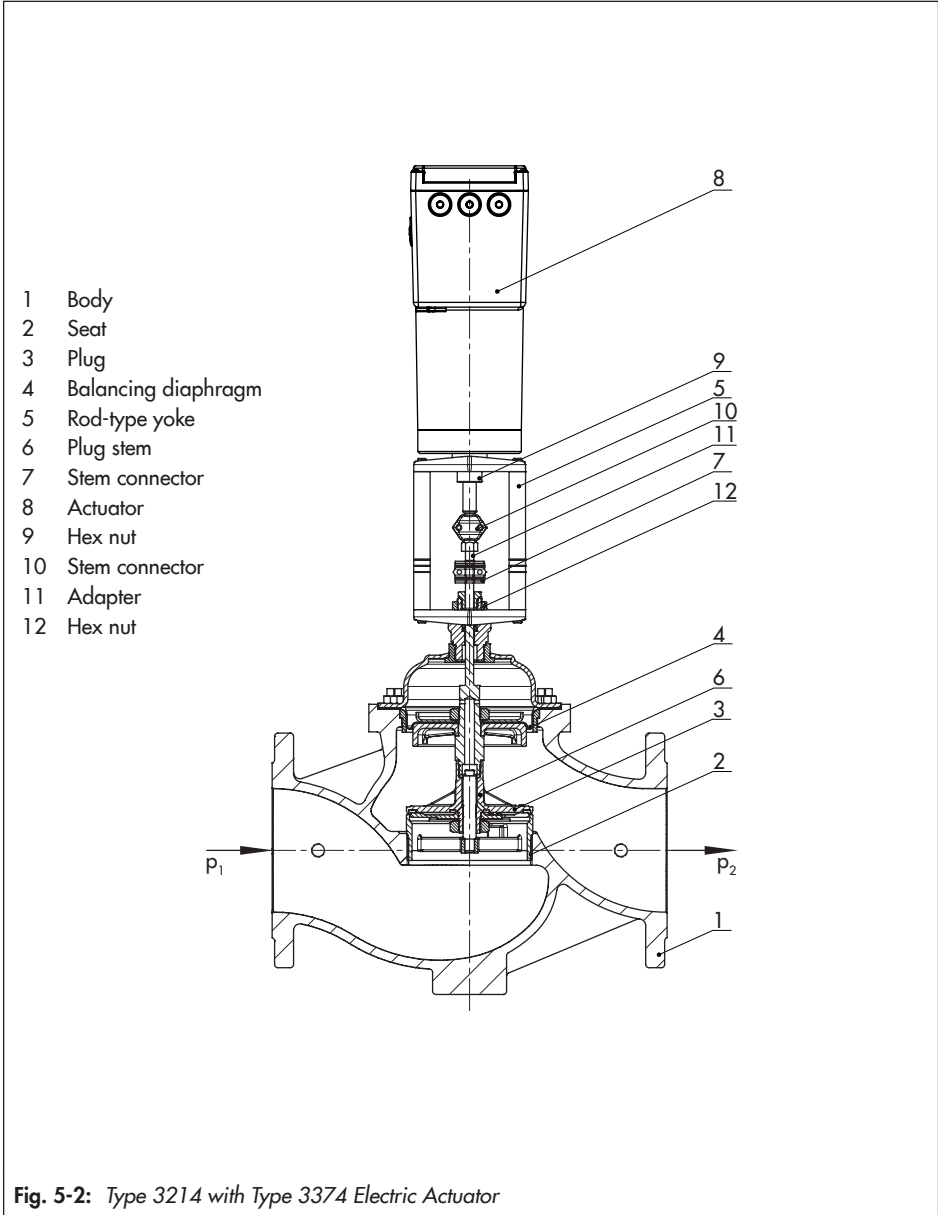

5.4 Testing the installed valve

⚠ DANGER

Risk of bursting due to incorrect opening of pressurized equipment or components.

Valves and pipelines are pressure equipment that may burst when handled incorrectly. Flying projectile fragments or the release of process medium under pressure can cause serious injury or even death.

Before working on the control valve:

- Depressurize all plant sections affected and the valve (including the actuator). Release any stored energy.
- Drain the process medium from the plant sections affected as well as from the valve.

⚠ DANGER

Risk of fatal injury due to electric shock.

- Do not remove any covers to perform adjustment work on live parts.
- Before performing any work on the device and before opening the device, disconnect the supply voltage and protect it against unintentional reconnection.
- Only use power interruption devices that are protected against unintentional reconnection of the power supply.

⚠ WARNING

Risk of hearing loss or deafness due to loud noise.

Noise emission (e.g. cavitation or flashing) may occur during operation caused by the

process medium and the operating conditions which can damage hearing.

- Wear hearing protection when working near the valve.

⚠ WARNING

Risk of burn injuries due to hot components and pipeline.

Valve components and the pipeline may become very hot. Risk of burn injuries.

- Allow components and pipelines to cool down.
- Wear protective clothing and safety gloves.

⚠ WARNING

Crush hazard arising from actuator and plug stem moving.

- Do not insert hands or finger into the yoke while the supply voltage is connected to the actuator.
- Disconnect and lock the supply voltage before performing any work on the control valve.
- Do not impede the movement of the actuator and plug stem by inserting objects into the yoke.
- Before unblocking the actuator and plug stem after they have become blocked (e.g. due to seizing up after remaining in the same position for a long time), release any stored energy in the actuator.

To test the valve functioning before start-up or putting back the valve into operation, perform the following tests:

5.4.1 Leakage

The plant operator is responsible for performing the leak test and selecting the test method. The leak test must comply with the requirements of the national and international standards that apply at the site of installation.



Tip

Our after-sales service can support you to plan and perform a leak test for your plant.

1. Slowly apply the test medium to the valve until the test pressure is reached. Avoid sudden surges in pressure since the resulting high velocities may damage the valve.
2. Check the valve for leakage to the atmosphere.
3. Depressurize the pipeline section and valve.
4. Rework any parts that leak and repeat the leak test.

5.4.2 Travel motion

The movement of the actuator stem must be linear and smooth.

- Apply the maximum and minimum control signals to check the end positions of the valve while observing the movement of the actuator stem.

- Check the travel reading at the travel indicator scale.

5.4.3 Fail-safe position

Fail-safe action for electric actuators with fail-safe action

- Switch off the supply voltage.
- Check whether the valve moves to the fail-safe position (see the 'Design and principle of operation' section).

5.4.4 Pressure test

The plant operator is responsible for performing the pressure test.



Note

Our after-sales service can support you to plan and perform a pressure test for your plant.

During the pressure test, make sure the following conditions are met:

- Retract the plug stem to open the valve.
- Observe the maximum permissible pressure for both the valve and plant.

6 Start-up

The work described in this section is to be performed only by personnel appropriately qualified to carry out such tasks.

⚠ WARNING

Risk of burn injuries due to hot components and pipeline.

Valve components and the pipeline may become very hot. Risk of burn injuries.

→ Wear protective clothing and safety gloves.

⚠ WARNING

Crush hazard arising from actuator and plug stem moving.

→ Do not insert hands or finger into the yoke while the supply voltage is connected to the actuator.

→ Disconnect and lock the supply voltage before performing any work on the control valve.

→ Do not impede the movement of the actuator and plug stem by inserting objects into the yoke.

→ Before unblocking the actuator and plug stem after they have become blocked (e.g. due to seizing up after remaining in the same position for a long time), release any stored energy in the actuator.

⚠ WARNING

Risk of hearing loss or deafness due to loud noise.

Noise emission (e.g. cavitation or flashing) may occur during operation caused by the process medium and the operating conditions which can damage hearing.

→ Wear hearing protection when working near the valve.

Before start-up or putting the valve back into service, make sure the following conditions are met:

- The valve is properly installed into the pipeline (see the 'Installation' section).
- The leak and function tests have been completed successfully (see the 'Installation' section > 'Testing the installed valve').
- The prevailing conditions in the plant section concerned meet the valve sizing requirements (see information under 'Intended use' in the 'Safety instructions and measures' section).

Start-up/putting the device back into operation

1. Allow the valve to warm up to reach ambient temperature before start-up when the ambient temperature and process medium temperature differ greatly or the medium properties require such a measure.
2. Slowly open the shut-off valves in the pipeline. Slowly opening these valves prevents a sudden surge in pressure and

high flow velocities which can damage the valve.

3. Check the valve to ensure it functions properly.

7 Operation

Immediately after completing start-up or putting the valve back into operation, the valve is ready for use.

⚠ WARNING

Risk of burn injuries due to hot components and pipeline.

Valve components and the pipeline may become very hot. Risk of burn injuries.

- Wear protective clothing and safety gloves.
-

⚠ WARNING

Crush hazard arising from actuator and plug stem moving.

- Do not insert hands or finger into the yoke while the supply voltage is connected to the actuator.
 - Disconnect and lock the supply voltage before performing any work on the control valve.
 - Do not impede the movement of the actuator and plug stem by inserting objects into the yoke.
 - Before unblocking the actuator and plug stem after they have become blocked (e.g. due to seizing up after remaining in the same position for a long time), release any stored energy in the actuator.
-

⚠ WARNING

Risk of hearing loss or deafness due to loud noise.

Noise emission (e.g. cavitation or flashing) may occur during operation caused by the process medium and the operating conditions which can damage hearing.

- Wear hearing protection when working near the valve.
-

8 Malfunctions

Read hazard statements, warnings and caution notes in the 'Safety instructions and measures' section.

Depending on the operating conditions, check the valve at certain intervals to prevent possible failure before it can occur. Plant operators are responsible for drawing up an inspection and test plan.



Tip

Our after-sales service can support you in drawing up an inspection and test plan for your plant.

8.1 Troubleshooting

Malfunction	Possible reasons	Recommended action
Actuator and plug stem does not move on demand.	Actuator is blocked.	Check attachment. Remove the blockage.
	No or incorrect supply voltage connected.	Check the supply voltage and connections.
Actuator and plug stem does not stroke through the full range.	No or incorrect supply voltage connected.	Check the supply voltage and connections.
Increased flow through closed valve (seat leakage)	Dirt or other foreign particles deposited between the seat and plug.	Shut off the section of the pipeline and flush the valve.
	Valve trim is worn out.	Contact our after-sales service.
The valve leaks to the atmosphere (fugitive emissions).	Plug stem seal defective	Contact our after-sales service.
	Flanged joint loose or gasket worn out	Check the flanged joint.

i Note

Contact our after-sales service for malfunctions not listed in the table.

8.2 Emergency action

The valve, on which the actuator with fail-safe action is mounted, is moved to its fail-safe position upon failure of the supply voltage (see the 'Design and principle of operation' section).

Plant operators are responsible for emergency action to be taken in the plant.

In the event of a valve malfunction:

1. Close the shut-off valves upstream and downstream of the control valve to stop the process medium from flowing through the valve.
2. Perform troubleshooting (see section 8.1).
3. Rectify those malfunctions that can be remedied based on the instructions provided here. Contact our after-sales service in all other cases.

Putting the device back into operation after a malfunction

See the 'Start-up' section.

9 Servicing

i Note

The control valve was checked by SAMSON before it left the factory.

- The product warranty becomes void if service or repair work not described in these instructions is performed without prior agreement by SAMSON's After-sales Service.*
 - Only use original spare parts by SAMSON, which comply with the original specifications.*
-

Ordering spare parts and operating supplies

Contact your nearest SAMSON subsidiary or SAMSON's After-sales Service for information on spare parts, lubricants and tools.

10 Decommissioning

The work described in this section is to be performed only by personnel appropriately qualified to carry out such tasks.

⚠ DANGER

Risk of bursting due to incorrect opening of pressurized equipment or components.

Valves and pipelines are pressure equipment that may burst when handled incorrectly.

Flying projectile fragments or the release of process medium under pressure can cause serious injury or even death.

Before working on the control valve:

- Depressurize all plant sections affected and the valve (including the actuator). Release any stored energy.
- Drain the process medium from the plant sections affected as well as from the valve.

⚠ DANGER

Risk of fatal injury due to electric shock.

- Before performing any work on the device and before opening the device, disconnect the supply voltage and protect it against unintentional reconnection.
- Only use power interruption devices that are protected against unintentional reconnection of the power supply.

⚠ WARNING

Risk of burn injuries due to hot components and pipeline.

Valve components and the pipeline may become very hot. Risk of burn injuries.

- Allow components and pipelines to cool down.
- Wear protective clothing and safety gloves.

⚠ WARNING

Crush hazard arising from actuator and plug stem moving.

- Do not insert hands or finger into the yoke while the supply voltage is connected to the actuator.
- Disconnect and lock the supply voltage before performing any work on the control valve.
- Do not impede the movement of the actuator and plug stem by inserting objects into the yoke.
- Before unblocking the actuator and plug stem after they have become blocked (e.g. due to seizing up after remaining in the same position for a long time), release any stored energy in the actuator.

⚠ WARNING

Risk of hearing loss or deafness due to loud noise.

Noise emission (e.g. cavitation or flashing) may occur during operation caused by the process medium and the operating conditions which can damage hearing.

Decommissioning

→ *Wear hearing protection when working near the valve.*

WARNING

Risk of personal injury due to residual process medium in the valve.

While working on the valve, residual process medium can escape and, depending on its properties, may lead to personal injury, e.g. burns.

→ *Wear protective clothing, safety gloves and eye protection.*

To decommission the control valve for disassembly, proceed as follows:

1. Close the shut-off valves upstream and downstream of the control valve to stop the process medium from flowing through the valve.
2. Completely drain the pipelines and valve.
3. Disconnect and lock the supply voltage to de-energize the actuator.
4. Release any stored energy.
5. If necessary, allow the pipeline and valve components to cool down.

11 Removal

The work described in this section is to be performed only by personnel appropriately qualified to carry out such tasks.

⚠ DANGER

Risk of fatal injury due to electric shock.

- Before performing any work on the device and before opening the device, disconnect the supply voltage and protect it against unintentional reconnection.
- Only use power interruption devices that are protected against unintentional reconnection of the power supply.

⚠ WARNING

Risk of burn injuries due to hot components and pipeline.

Valve components and the pipeline may become very hot. Risk of burn injuries.

- Allow components and pipelines to cool down.
- Wear protective clothing and safety gloves.

⚠ WARNING

Risk of personal injury due to residual process medium in the valve.

While working on the valve, residual process medium can escape and, depending on its properties, may lead to personal injury, e.g. burns.

- Wear protective clothing, safety gloves and eye protection.

Before removing the valve, make sure the following conditions are met:

- The control valve is put out of operation (see the 'Decommissioning' section).

11.1 Removing the valve from the pipeline

1. Support the valve to hold it in place when separated from the pipeline (see the 'Shipment and on-site transport' section).
2. Unbolt the flanged joint.
3. Remove the valve from the pipeline (see the 'Shipment and on-site transport' section).

11.2 Removing the actuator from the valve

Removing Type 3374 Actuator from the valve

- See associated actuator documentation.

Removing the rod-type yoke

1. Remove the stem connector clamps (7) and adapter (11).
2. Unscrew the hex nut (12) from the rod-type yoke (5).
3. Remove the rod-type yoke (5) from the body (1).

Removal

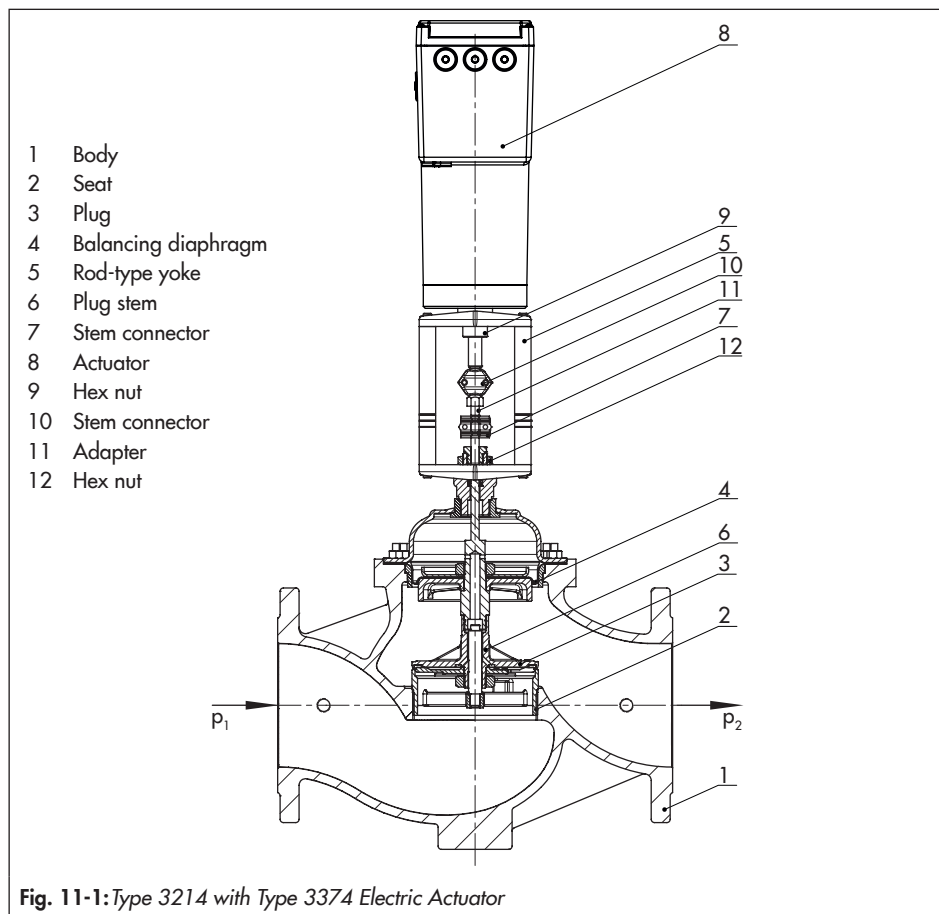

12 Repairs

If the valve does not function properly according to how it was originally sized or does not function at all, it is defective and must be repaired or exchanged.

! NOTICE

Risk of valve damage due to incorrect repair work.

- Do not perform any repair work on your own.
- Contact SAMSON's After-sales Service for repair work.

12.1 Returning devices to SAMSON

Defective devices can be returned to SAMSON for repair.

Proceed as follows to return devices:

1. Exceptions apply concerning some special device models
 - ▶ www.samsongroup.com > Service & Support > After-sales Service.
2. Send an e-mail ▶ retouren@samsongroup.com to register the return shipment including the following information:
 - Type
 - Article no.
 - Configuration ID
 - Original order

- Completed Declaration on Contamination, which can be downloaded from our website at
 - ▶ www.samsongroup.com > Service & Support > After-sales Service.

After checking your registration, we will send you a return merchandise authorization (RMA).

3. Attach the RMA (together with the Declaration on Decontamination) to the outside of your shipment so that the documents are clearly visible.
4. Send the shipment to the address given on the RMA.

i Note

Further information on returned devices and how they are handled can be found at

- ▶ www.samsongroup.com > Service & Support > After-sales Service.

13 Disposal

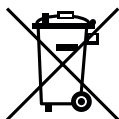

SAMSON is a producer registered at the following European institution
 ► <https://www.ewrn.org/national-registers/national-registers>.
 WEEE reg. no.: DE 62194439/
 FR 02566

- ➔ Observe local, national and international refuse regulations.
- ➔ Do not dispose of components, lubricants and hazardous substances together with your household waste.

i Note

We can provide you with a recycling passport according to PAS 1049¹⁾ on request. Simply e-mail us at offersaleservice@samsongroup.com giving details of your company address.

Tip

On request, we can appoint a service provider to dismantle and recycle the product as part of a distributor take-back scheme.

¹⁾ PAS 1049 is relevant to electrical and electronic equipment (e.g. electric actuators). This PAS specification does not apply to non-electrical equipment.

14 Certificates

The declarations and certificates are included on the next pages:

- Declaration of conformity in compliance with Pressure Equipment Directive 2014/68/EU on pages 14-2 to 14-8
- Declaration of conformity in compliance with Machinery Directive 2006/42/EC for Types 3214-1 and 3214-7 Control Valves on page 14-9
- Declaration of incorporation in compliance with Machinery Directive 2006/42/EC for the Type 3214 Valve with other actuators other than Types 3271 and 3277 Actuators on page 14-10

The certificates shown were up to date at the time of publishing. The latest certificates can be found on our website:

► www.samsongroup.com > *Products* > *Valves* > *3214*

Other optional certificates are available on request.

EU DECLARATION OF CONFORMITY TRANSLATION



Module A

For the following products, SAMSON hereby declares under its sole responsibility:

Devices	Series	Type	Version		
Self-operated Regulators	43	2432	DIN EN, body, CC499K and EN-GJS-400-18-LT, DN 50, PN 25, fluids G2, L2, L1 ¹⁾		
	43	2436	DIN EN, body, CC499K and EN-GJS-400-18-LT, DN 50, PN 25, fluids G2, L2, L1 ¹⁾		
	43	2437	DIN EN, body, CC499K and EN-GJS-400-18-LT, DN 50, PN 25, fluids G2, L2, L1 ¹⁾		
	---	2111	DIN EN, body, EN-GJS-400-18-LT, DN 50, PN 25, fluids G2, L2, L1 ¹⁾ DIN EN, body, 1.0619 and 1.4408, DN 40-50, PN 40, fluids G2, L2, L1 ¹⁾ ANSI, body, A216 WCC and A351 CF8M, NPS 1½-2, Class 300, fluids G2, L2, L1 ¹⁾		
Three-way valve	---	2119	DIN EN, body, EN-GJL-250 and 1.0619, DN 65-125, PN 16, fluids G2, L2, L1 ¹⁾		
			DIN EN, body, 1.0619, DN 50-80, PN 25, fluids G2, L2, L1 ¹⁾		
			DIN EN, body, 1.0619 and 1.4408, DN 40-50, PN 40, fluids G2, L2, L1 ¹⁾		
			ANSI, body, A216 WCC and A351 CF8M, NPS 2¼-4, Class 150, fluids G2, L2, L1 ¹⁾ ANSI, body, A216 WCC and A351 CF8M, NPS 1½, Class 300, fluids G2, L2, L1 ¹⁾		
Control valve	---	3222	DIN EN, body, EN-GJS-400-18-LT, DN 50, PN 25, fluids G2, L2, L1 ¹⁾ DIN EN, body, CC499K, DN 32-40, PN 25, all fluids		
Three-way valve	---	3226	DIN EN, body, CC499K, DN 50, PN 25, fluids G2, L2 ²⁾		
Three-way valve	---	3260	DIN EN, body, EN-GJL-250, DN 65-200, PN 16, fluids G2, L2 ²⁾		
Globe valve Three-way valve	V2001	3531	DIN EN, body, EN-GJS-400-18-LT, DN 50-80, PN 25, fluids G2, L2, L1 ¹⁾		
		3535	DIN EN, body, 1.0619 and 1.4408, DN 32-40, PN 25, all fluids ANSI, body, A216 WCC and A351 CF8M, NPS 1½-2, Class 150, all fluids		
Control valve	---	3214	DIN EN, body, EN-GJL-250, DN 65-125, PN 16, fluids G2, L2, L1 ¹⁾		
			DIN EN, body, EN-GJS-400-18-LT, DN 50-80, PN 25, fluids G2, L2, L1 ¹⁾		
			ANSI, body, A126 B, NPS 3-4, Class 125, fluids G2, L2, L1 ¹⁾		
			ANSI, body, A216 WCC and A351 CF8M, NPS 1½-2, Class 150, all fluids DIN EN, body, EN-GJL-250 and EN-GJS-400-18-LT, DN 65-125, PN 16, fluids G2, L2, L1 ¹⁾		
Self-operated Regulators	42	2423	DIN EN, body, EN-GJS-418-LT, DN 50-80, PN 25, fluids G2, L2, L1 ¹⁾		
			DIN EN, body, 1.0619 and 1.4408, DN 32-50, PN 16, all fluids		
			DIN EN, body, 1.0619 and 1.4408, DN 32-40, PN 25, all fluids		
			ANSI, body, A126 B, NPS 3-4, Class 125, fluids G2, L2, L1 ¹⁾ ANSI, body, A216 WCC and A351 CF8M, NPS 1½-2, Class 150, all fluids		
	42	2422	DIN EN, body, EN-GJL-250 and EN-GJS-400-18-LT, DN 65-125, PN 16, fluids G2, L2, L1 ¹⁾		
			DIN EN, body, EN-GJS-400-18-LT, DN 50-80, PN 25, fluids G2, L2, L1 ¹⁾		
			DIN EN, body, 1.0619, 1.4408 and 1.6220+QT, DN 32-50, PN 16, all fluids		
			ANSI, body, A126 B, NPS 3-4, Class 125, fluids G2, L2, L1 ¹⁾ ANSI, body, A216 WCC, A351 CF8M and A352 LCC, NPS 1½-2, Class 150, all fluids		
Strainers	1N/1NI	2601	DIN EN, body, CB752S, G 2 (DN50), PN25, fluids G2, L2 ²⁾ DIN EN, body, EN-GJL-250, DN 200-250, PN 10, fluids G2, L2, L1 ¹⁾		
Strainers	2N/2NI	2602	DIN EN, body, EN-GJL-250, DN 65-125, PN 16, fluids G2, L2, L1 ¹⁾		
			DIN EN, body, EN-GJS-400-18-LT, DN 100-125, PN 16, fluids G2, L2, L1 ¹⁾		
			DIN EN, body, EN-GJS-400-18-LT, DN 50-80, PN 25, fluids G2, L2, L1 ¹⁾		
			DIN EN, body, 1.4408, DN 32-50, PN 16, all fluids		
Self-operated Regulators	---	2373/2375	ANSI, body, A995 4A and A995 5A, NPS 1½-2, Class 150, all fluids		
			44	2440 (44-0B) 2441 (44-1B) 2446 (44-6B)	DIN EN, body, EN-GJS-400-18-LT, DN 50, PN 25, fluids G2, L2, L1 ¹⁾
					2442 (44-2) 2443 (44-3) 2444 (44-4) 2447 (44-7) 2448 (44-8) 2449 (44-9)

Revision 00

EU DECLARATION OF CONFORMITY TRANSLATION



Devices	Series	Type	Version
Self-operated Regulators	45	2451 (45-1)	DIN EN, body, EN-GJS-400-18-LT and CC499K, DN 50, PN 25, fluids G2, L2, L1 ¹⁾
		2452 (45-2)	
		2453 (45-3)	
		2454 (45-4)	
		2456 (45-6)	
	46	2465 (46-5)	DIN EN, body, EN-GJS-400-18-LT and CC499K, DN 50, PN 25, fluids G2, L2, L1 ¹⁾
		2466 (46-6)	
		2467 (46-7)	
	47	2471 (47-1)	DIN EN, body, EN-GJS-400-18-LT and CC499K, DN 50, PN 25, fluids G2, L2, L1 ¹⁾
		2474 (47-4)	
		2475 (47-5)	
	48	2488	DIN EN, body, EN-GJS-400-18-LT and CC499K, DN 50, PN 25, fluids G2, L2, L1 ¹⁾
		2489	
	40	2405	DIN EN, body, EN-GJS-400-18-LT, DN 50, PN 25, fluids G2, L2, L1 ¹⁾
			ANSI, body, A216 WCC and A351 CF8M, NPS 1½-2, Class 150, all fluids
			DIN EN, body, EN-GJL-250, DN 65-125, PN 16, fluids G2, L2, L1 ¹⁾
			DIN EN, body, EN-GJS-400-18-LT, DN 50, PN 25, fluids G2, L2, L1 ¹⁾
			ANSI, body, A126 B, NPS 3-4, Class 125, fluids G2, L2, L1 ¹⁾
		2406	ANSI, body, A216 WCC and A351 CF8M, NPS 1½-2, Class 150, all fluids
			DIN EN, body, EN-GJL-250, DN 65-100, PN 16, fluids G2, L2, L1 ¹⁾
			DIN EN, body, EN-GJS-400-18-LT, DN 50-80, PN 25, fluids G2, L2, L1 ¹⁾
			ANSI, body, A126 B, NPS 3-4, Class 125, fluids G2, L2, L1 ¹⁾
			ANSI, body, A216 WCC and A351 CF8M, NPS 1½-2, Class 150, all fluids
	41	2412 2417	DIN EN, body, EN-GJL-250, DN 65-100, PN 16, fluids G2, L2, L1 ¹⁾
			DIN EN, body, EN-GJS-400-18-LT, DN 50-80, PN 25, fluids G2, L2, L1 ¹⁾
			ANSI, body, A126 B, NPS 3-4, Class 125, fluids G2, L2, L1 ¹⁾
	42	2421 RS	ANSI, body, A216 WCC and A351 CF8M, NPS 1½-2, Class 150, all fluids
			DIN EN, body, 1.0619, 1.4408, 1.4571 and 1.4401/1.4404, DN 32-50, PN 16, all fluids
			DIN EN, body, 1.0619, 1.4408, 1.4571 and 1.4401/1.4404, DN 32-40, PN 25, all fluids
	---	2331 2337	ANSI, body, A216 WCC, A351 CF8M and A182 F316/A182 F316L, NPS 1½-2, Class 150, all fluids
			DIN EN, body, EN-GJL-250, DN 65-200, PN 16, fluids G2, L2 ²⁾
			DIN EN, body, EN-GJS-400-18-LT, DN 65-150, PN 16, fluids G2, L2 ²⁾
			DIN EN, body, EN-GJS-400-18-LT, DN 65-125, PN 25, fluids G2, L2 ²⁾
			DIN EN, body 1.0619, DN 65-200, PN 16, fluids G2, L2 ²⁾
	---	2333 2335	DIN EN, body 1.0619, DN 65-100, PN 40, fluids G2, L2 ²⁾
			DIN EN, body, EN-GJL-250, DN 65-125, PN 16, fluids G2, L2, L1 ¹⁾
			DIN EN, body, EN-GJS-400-18-LT, DN 65-80, PN 25, fluids G2, L2, L1 ¹⁾
	---	2334	ANSI, body, A126 B, NPS 3-4, Class 125, fluids G2, L2, L1 ¹⁾
			DIN EN, body, EN-GJL-250, DN 65-125, PN 16, fluids G2, L2, L1 ¹⁾
			DIN EN, body, EN-GJS-400-18-LT, DN 65-125, PN 16, fluids G2, L2, L1 ¹⁾
DIN EN, body, EN-GJS-400-18-LT, DN 65-80, PN 25, fluids G2, L2, L1 ¹⁾			
---	2404-1	ANSI, body, A126 B, NPS 3-4, Class 125, fluids G2, L2, L1 ¹⁾	
		DIN EN, body, EN-GJS-400-18-LT, DN 65-80, PN 25, fluids G2, L2, L1 ¹⁾	
		ANSI, body, A216 WCC and A351 CF8M, NPS 1½-2, Class 150, all fluids	
---	2404-2	DIN EN, body, EN-GJL-250, DN 65-125, PN 16, fluids G2, L2, L1 ¹⁾	
		ANSI, body, A126 B, NPS 3-4, Class 125, fluids G2, L2, L1 ¹⁾	

¹⁾ Gases according to Article 4(1)(c.i), second indent
Liquids according to Article 4(1)(c.ii)

²⁾ Gases according to Article 4(1)(c.i), second indent
Liquids according to Article 4(1)(c.ii), second indent

EU DECLARATION OF CONFORMITY TRANSLATION



That the products mentioned above comply with the requirements of the following standards:

Directive of the European Parliament and of the Council on the harmonization of the laws of the Member States relating to the making available on the market of pressure equipment	2014/68/EU	of 15. May 2014
Applied conformity assessment procedure for fluids according to Article 4(1)	Module A	

Technical standards applied: DIN EN 12516-2, DIN EN 12516-3, ASME B16.34

Manufacturer: SAMSON AG, Weismüllerstraße 3, 60314 Frankfurt am Main, Germany

Frankfurt am Main, 26. August 2022

Handwritten signature of Norbert Tollas in blue ink.

ppa. Norbert Tollas
Senior Vice President
Global Operations

Handwritten signature of Peter Scheermesser in blue ink.

i.V. Peter Scheermesser
Director
Product Maintenance & Engineered Products

Revision 00

Classification: Public · SAMSON AKTIENGESELLSCHAFT · Weismuellerstrasse 3 · 60314 Frankfurt am Main, Germany

Page 3 of 3

EU DECLARATION OF CONFORMITY
TRANSLATION



Module D / N° CE-0062-PED-D-SAM 001-22-DEU

For the following products, SAMSON hereby declares under its sole responsibility:

Devices	Series	Type	Version
Control valve for hot water and steam with fail-safe action in heating systems	Actuator 3374-21/-26 (Force 2000 N)		with Type 3241, 2811, 2814, 2823, 3321 EU-Type examination (production type), Module B, Certificate no.: 01 202 931/B-15-0030-01, type-tested according to standard DIN EN 14597:2015
Control valve for water and water-steam with fail-safe action in heating systems	Actuator 5725-310/-313/-320/-323 5725-810/-820 5825-10/-13/-20/-23 (Force 500 N) (Product number 2770)		with Type 3214 (2814), 2423 (2823), 3213 (2710), 3222 (2710), 2488 (2730), 2489 (2730) EU-Type examination (production type), Module B, Certificate no.: 01 202 641/B-19-0017-01 type-tested according to standard DIN EN 14597:2015, appendix DX

that the products mentioned above comply with the requirements of the following standards:

Directive of the European Parliament and of the Council on the harmonization of the laws of the Member States relating to the making available on the market of pressure equipment	2014/68/EU	of 15 May 2014
Applied conformity assessment procedure for fluids according to Article 4(1)	Module D	Certificate-No.: N°CE-0062-PED-D-SAM 001-22-DEU by Bureau Veritas 0062

The manufacturer's quality management system is monitored by the following notified body:
Bureau Veritas Services SAS, 8 Cours du Triangle, 92800 PUTEAUX – LA DEFENSE

Applied harmonised standards and technical specifications: EN 12516-2, EN 12516-3, EN 12266-1, ASME B16.34

Manufacturer: SAMSON AKTIENGESELLSCHAFT, Weismüllerstraße 3, 60314 Frankfurt am Main, Germany

Frankfurt am Main, 15th November 2022

Dr. Andreas Widl
Chief Executive Officer (CEO)

Dr. Thomas Steckenreiter
Chief Technology Officer (CTO)

Revision 09

Classification: Public · SAMSON AKTIENGESELLSCHAFT · Weismüllerstraße 3 · 60314 Frankfurt am Main, Germany

Page 1 of 1

EU DECLARATION OF CONFORMITY TRANSLATION



Module H / N° CE-0062-PED-H-SAM 001-22-DEU

For the following products, SAMSON hereby declares under its sole responsibility:

Devices	Series	Type	Version
Three-way valve	---	2119	DIN EN, body, EN-GJL-250 and 1.0619, DN 150, PN 16, fluids G2, L2, L1 ¹⁾
			DIN EN, body, 1.0619, DN 100-150, PN 25, fluids G2, L2, L1 ¹⁾
			DIN EN, body, 1.0619 and 1.4408, DN 65-150, PN 40, fluids G2, L2, L1 ¹⁾
			ANSI, body, A216 WCC and A351 CF8M, NPS 6, Class 150, fluids G2, L2, L1 ¹⁾
			ANSI, body, A216 WCC and A351 CF8M, NPS 2-6, Class 300, fluids G2, L2, L1 ¹⁾
Self-operated Regulators	---	3222	DIN EN, body, CC499K, DN 50, PN 25, all fluids
Three-way valve	---	3260	DIN EN, body, EN-GJL-250, DN 250-300, PN 16, fluids G2, L2 ¹⁾
Globe valve Three-way valve	V2001	3531	DIN EN, body, 1.0619 and 1.4408, DN 50-80, PN 25, all fluids
		3535	ANSI, body, A216 WCC and A351 CF8M, NPS 2½-3, Class 150, all fluids
Control valve	---	3214	DIN EN, body, EN-GJL-250, DN 150-400, PN 16, fluids G2, L2, L1 ¹⁾
			DIN EN, body, EN-GJS-400-18-LT, DN 100-150, PN 25, fluids G2, L2, L1 ¹⁾
			DIN EN, body, 1.0619, DN 32-400, PN 40, all fluids
			ANSI, body, A126 B, NPS 6-10, Class 125, fluids G2, L2, L1 ¹⁾
			ANSI, body, A216 WCC, NPS 2½-10, Class 150, all fluids
			ANSI, body, A216 WCC, NPS 1½-10, Class 300, all fluids
			ANSI, body, A216 WCC and A351 CF8M, NPS 1½-10, Class 300, all fluids
Self-operated Regulators	42	2423	DIN EN, body, EN-GJL-250, DN 150-250, PN 16, fluids G2, L2, L1 ¹⁾
			DIN EN, body, EN-GJS-400-18-LT, DN 150, PN 16, fluids G2, L2, L1 ¹⁾
			DIN EN, body, EN-GJS-400-18-LT, DN 100-150, PN 25, fluids G2, L2, L1 ¹⁾
			DIN EN, body, 1.0619 and 1.4408, DN 65-250, PN 16, all fluids
			DIN EN, body, 1.0619 and 1.4408, DN 50-250, PN 25, all fluids
			DIN EN, body, 1.0619 and 1.4408, DN 32-250, PN 40, all fluids
			ANSI, body, A126 B, NPS 6-10, Class 125, fluids G2, L2, L1 ¹⁾
			ANSI, body, A216 WCC and A351 CF8M, NPS 2½-10, Class 150, all fluids
			ANSI, body, A216 WCC and A351 CF8M, NPS 1½-10, Class 300, all fluids
			DIN EN, body, EN-GJL-250, DN 150-400, PN 16, fluids G2, L2, L1 ¹⁾
			DIN EN, body, EN-GJS-400-18-LT, DN 100-150, PN 25, fluids G2, L2, L1 ¹⁾
			DIN EN, body, 1.0619 and 1.4408, DN 65-400, PN 16, all fluids
			DIN EN, body, 1.0619 and 1.4408, DN 200-400, PN 25, all fluids
			DIN EN, body, 1.0619 and 1.4408, DN 32-400, PN 40, all fluids
			DIN EN, body, 1.0480, DN 40-50, PN 40, all fluids
			DIN EN, body, 1.6220+QT, DN 65-250, PN 16, all fluids
	DIN EN, body, 1.6220+QT, DN 200-250, PN 25, all fluids		
	DIN EN, body, 1.6220+QT, DN 32-250, PN 40, all fluids		
	ANSI, body, A126 B, NPS 6-16, Class 125, fluids G2, L2, L1 ¹⁾		
	ANSI, body, A216 WCC and A351CF8M, NPS 2½-16, Class 150, all fluids		
	ANSI, body, A216 WCC and A351CF8M, NPS 1½-16, Class 300, all fluids		
	ANSI, body, A105, NPS 1½-2, Class 300, all fluids		
	ANSI, body, A352 LCC, NPS 2½-10, Class 150, all fluids		
	ANSI, body, A352 LCC, NPS 1½-10, Class 300, all fluids		
	42	2421RS	DIN EN, body, 1.0619 and 1.4408, DN 65-150, PN 16, all fluids
			DIN EN, body, 1.0619 and 1.4408, DN 50-150, PN 25, all fluids
			DIN EN, body, 1.0619 and 1.4408, DN 32-150, PN 40, all fluids
			DIN EN, body, 1.4571 and 1.4401/1.4404, DN 50, PN 25, all fluids
			DIN EN, body, 1.4571 and 1.4401/1.4404, DN 32-50, PN 40, all fluids
			ANSI, body, A216 WCC and A351 CF8M, NPS 2½-6, Class 150, all fluids
			ANSI, body, A216 WCC and A351 CF8M, NPS 1½-6, Class 300, all fluids
			ANSI, body, A216 WCC and A351 CF8M, NPS 1½-6, Class 300, all fluids

Revision 00

EU DECLARATION OF CONFORMITY

TRANSLATION



Devices	Series	Type	Version		
Self-operated Regulators	40	2405	DIN EN, body, 1.0619, 1.4571, 1.4404, 1.4408, 1.0460, DN 32-50, PN40, all fluids		
			ANSI, body, A105, A182 F316L, A351 CF8M, A216 WCC, NPS 1½-2, Class 300, all fluids		
		2406	DIN EN, body, EN-GJL-250, DN 150, PN 16, fluids G2, L2, L1 ¹⁾		
			DIN EN, body, 1.0619 and 1.4408, DN 32-150, PN 40, all fluids		
			DIN EN, body, 1.0460 and 1.4404, DN 32-50, PN 40, all fluids		
			ANSI, body, A126 B, NPS 6, Class 125, fluids G2, L2, L1 ¹⁾		
	41	2412	ANSI, body, A216 WCC and A351 CF8M, NPS 2½-6, Class 150, all fluids		
			ANSI, body, A216 WCC and A351 CF8M, NPS 1½-6, Class 300, all fluids		
		2417	ANSI, body, A105 and A182 F316L, NPS 1½-2, Class 300, all fluids		
			DIN EN, body, EN-GJS-400-18-LT, DN 100, PN25, fluids G2, L2, L1 ¹⁾		
			DIN EN, body, 1.0619 and 1.4408, DN 32-100, PN 40, all fluids		
			DIN EN, body, 1.0460, 1.4571 and 1.4404, DN 32-80, PN 40, all fluids		
	---	2404-1	ANSI, body, A216 WCC and A351 CF8M, NPS 2½-4, Class 150, all fluids		
			ANSI, body, A216 WCC and A351 CF8M, NPS 1½-4, Class 300, all fluids		
		---	2404-2	ANSI, body, A105 and A182 F316L, NPS 1½-3, Class 300, all fluids	
				DIN EN, body, EN-GJL-250, DN 150, PN16, fluids G2, L2, L1 ¹⁾	
			---	2404-2	DIN EN, body, 1.0619 und 1.4408, DN 32-150, PN 40, all fluids
					ANSI, body, A126 B, NPS 6, Class 125, fluids G2, L2, L1 ¹⁾
	---	2331	ANSI, body, A216 WCC und A351 CF8M, NPS 2½-6, Class 150, all fluids		
			ANSI, body, A216 WCC und A351 CF8M, NPS 1½-6, Class 300, all fluids		
		---	2337	DIN EN, body, EN-GJL-250, DN 150-400, PN 16, fluids G2, L2, L1 ¹⁾	
				DIN EN, body, 1.0619 und 1.4408, DN 65-400, PN 16, all fluids	
			---	2337	DIN EN, body, 1.0619 und 1.4408, DN 65-400, PN 40, all fluids
					ANSI, body, A126 B, NPS 6-16, Class 125, fluids G2, L2, L1 ¹⁾
	---	2333	ANSI, body, A216 WCC und A351 CF8M, NPS 2½-16, Class 150, all fluids		
			ANSI, body, A216 WCC und A351 CF8M, NPS 2½-10, Class 300, all fluids		
		---	2335	DIN EN, body, EN-GJL-250, DN 250, PN 16, fluids G2, L2 ¹⁾	
				DIN EN, body, 1.0619, DN 250, PN 16, fluids G2, L2 ¹⁾	
			---	2335	DIN EN, body, 1.0619, DN 200-250, PN 25, fluids G2, L2 ¹⁾
					DIN EN, body, 1.0619, DN 125-250, PN 40, fluids G2, L2 ¹⁾
	---	2334	DIN EN, body, EN-GJL-250, DN 150-400, PN 16, fluids G2, L2, L1 ¹⁾		
			DIN EN, body, EN-GJS-400-18-LT, DN 100-150, PN 25, fluids G2, L2, L1 ¹⁾		
		---	2334	DIN EN, body, 1.0619 and 1.4408, DN 65-400, PN 16, all fluids	
				DIN EN, body, 1.0619 and 1.4408, DN 200-400, PN 25, all fluids	
			---	2334	DIN EN, body, 1.0619 and 1.4408, DN 65-400, PN 40, all fluids
					ANSI, body, A126 B, NPS 6-16, Class 125, fluids G2, L2, L1 ¹⁾
---	2373	ANSI, body, A216 WCC and A351 CF8M, NPS 2½-16, Class 150, all fluids			
		ANSI, body, A216 WCC and A351 CF8M, NPS 2½-16, Class 300, all fluids			
	---	2375	DIN EN, body, EN-GJL-250, DN 150-400, PN 16, fluids G2, L2, L1 ¹⁾		
			DIN EN, body, EN-GJS-400-18-LT, DN 150, PN 16, fluids G2, L2, L1 ¹⁾		
		---	2375	DIN EN, body, 1.0619 and 1.4408, DN 65-400, PN 16, all fluids	
				DIN EN, body, 1.0619 and 1.4408, DN 200-400, PN 25, all fluids	
Strainers	2N/2NI	2602	DIN EN, body, 1.0619 and 1.4408, DN 65-400, PN 40, all fluids		
			ANSI, body, A126 B, NPS 6-16, Class 125, fluids G2, L2, L1 ¹⁾		
		---	2602	DIN EN, body, EN-GJL-250, DN 150-250, PN 16, fluids G2, L2, L1 ¹⁾	
				DIN EN, body, EN-GJS-400-18-LT, DN 150, PN 16, fluids G2, L2, L1 ¹⁾	
			---	2602	DIN EN, body, EN-GJS-400-18-LT, DN 100-150, PN 25, fluids G2, L2, L1 ¹⁾
					DIN EN, body, 1.0619, DN 100-250, PN 16, all fluids

Revision 00

Classification: Public · SAMSON AKTIENGESELLSCHAFT · Weismuellerstrasse 3 · 60314 Frankfurt am Main, Germany

Page 2 of 3

EU DECLARATION OF CONFORMITY

TRANSLATION



Devices	Series	Type	Version
Strainers	2N/2NI	2602	DIN EN, body, 1.0619, DN 200-250, PN 25, all fluids
			DIN EN, body, 1.0619, DN 32-250, PN 40, all fluids
			DIN EN, body, 1.4408, DN 65-100, PN 16, all fluids
			DIN EN, body, 1.4408, DN 32-100, PN 40, all fluids

¹⁾ Gases according to Article 4(1)(c.i), second indent
Liquids according to Article 4(1)(c.ii)

That the products mentioned above comply with the requirements of the following standards:

Directive of the European Parliament and of the Council on the harmonization of the laws of the Member States relating to the making available on the market of pressure equipment	2014/68/EU	of 15. May 2014
Applied conformity assessment procedure for fluids according to Article 4(1)	Module H	by Bureau Veritas 0062

The manufacturer's quality management system is monitored by the following notified body:
Bureau Veritas Services SAS, 8 Cours du Triangle, 92800 PUTEAUX – LA DEFENSE, FRANCE
Technical standards applied: DIN EN 12516-2, DIN EN 12516-3, ASME B16.34

Manufacturer: SAMSON AG, Weismuellerstrasse 3, 60314 Frankfurt am Main, Germany

Frankfurt am Main, 14. October 2022



ppa. Norbert Tollas
Senior Vice President
Global Operations



i.V. Peter Scheermesser
Director
Product Maintenance & Engineered Products

Revision 00



Konformitätserklärung für eine vollständige Maschine

nach Anhang II, Absatz 1.A. der Richtlinie 2006/42/EG

Für folgendes Produkt:

Elektrisches Stellventil Typ 3214/XXXX bestehend aus Ventil Typ 3214 und Antrieb Typ 3374, Typ 3274 oder Typ 3375

Wir, die SAMSON AG, erklären, dass die oben genannte Maschine allen einschlägigen Anforderungen der Maschinenrichtlinie 2006/42/EG entspricht.

Produktbeschreibung siehe:

- Elektrische Stellventile Typ 3214/3374, 3214/3274, 3214/3375:
Einbau- und Bedienungsanleitung EB 5868-1

Folgende technischen Normen und/oder Spezifikationen wurden angewandt:

- VCI/VDMA/VGB – Leitfaden Maschinenrichtlinie (2006/42/EG) – Bedeutung für Armaturen, Mai 2018
- VCI/VDMA/VGB – Zusatzdokument zum „Leitfaden Maschinenrichtlinie (2006/42/EG) – Bedeutung für Armaturen vom Mai 2018“, Stand Mai 2018 in Anlehnung an DIN EN ISO 12100:2011-03

Bemerkung:

Bestehende Restrisiken der Maschine sind den Angaben in der Einbau- und Bedienungsanleitung von Ventil und Antrieb sowie den in der Einbau- und Bedienungsanleitung aufgeführten, mitgelieferten Dokumenten zu entnehmen.

Für die Zusammenstellung der technischen Unterlagen ist bevollmächtigt:
SAMSON AG, Weismüllerstraße 3, 60314 Frankfurt am Main, Germany
Frankfurt am Main, 20. October 2023

ppa. Norbert Tollas
Senior Vice President
Global Operations

i.V. Peter Scheermesser
Director
Product Maintenance & Engineered Products

Revision 00

DECLARATION OF INCORPORATION TRANSLATION



Declaration of Incorporation in Compliance with Machinery Directive 2006/42/EC

For the following product:

Type 3214 Valve

We certify that the Type 3214 Valve is partly completed machinery as defined in the Machinery Directive 2006/42/EC and that the safety requirements stipulated in Annex I, 1.1.2, 1.1.3, 1.1.5, 1.3.2, 1.3.4 and 1.3.7 are observed. The relevant technical documentation described in Annex VII, part B has been compiled.

Products we supply must not be put into service until the final machinery into which it is to be incorporated has been declared in conformity with the provisions of the Machinery Directive 2006/42/EC.

Operators are obliged to install the products observing the accepted industry codes and practices (good engineering practice) as well as the mounting and operating instructions. Operators must take appropriate precautions to prevent hazards that could be caused by the process medium and operating pressure in the valve as well as by the signal pressure and moving parts.

The permissible limits of application and mounting instructions for the products are specified in the associated mounting and operating instructions; the documents are available in electronic form on the Internet at www.samsongroup.com.

For product descriptions refer to:

- Type 3214/... Electric and Pneumatic Control Valves:
Mounting and Operating Instructions EB 5868/5869
- Types 3214/3374, 3214/3274 and Electric Control Valves 3214/3375:
Mounting and Operating Instructions EB 5868-1

Referenced technical standards and/or specifications:

- VCI, VDMA, VGB: "Leitfaden Maschinenrichtlinie (2006/42/EG) – Bedeutung für Armaturen, Mai 2018" [German only]
- VCI, VDMA, VGB: "Zusatzdokument zum Leitfaden Maschinenrichtlinie (2006/42/EG) – Bedeutung für Armaturen vom Mai 2018" [German only], based on DIN EN ISO 12100:2011-03

Comments:

- See mounting and operating instructions for residual hazards.
- Also observe the referenced documents listed in the mounting and operating instructions.

Persons authorized to compile the technical file:

SAMSON AG, Weismüllerstraße 3, 60314 Frankfurt am Main, Germany
Frankfurt am Main, 20 October 2023

A handwritten signature in blue ink, appearing to read "S. Giesen", written over a horizontal line.

Stephan Giesen
Director
Product Management

A handwritten signature in blue ink, appearing to read "P. Scheermesser", written over a horizontal line.

Peter Scheermesser
Director
Product Maintenance & Engineered Products

Revision no. 00

15 Annex

15.1 After-sales service

Contact our after-sales service for support concerning service or repair work or when malfunctions or defects arise.

E-mail address

You can reach our after-sales service at aftersalesservice@samsongroup.com.

Addresses of SAMSON AG and its subsidiaries

The addresses of SAMSON AG, its subsidiaries, representatives and service facilities worldwide can be found on our website (www.samsongroup.com) or in all SAMSON product catalogs.

Required specifications

Please submit the following details:

- Order number and position number in the order
- Type, model number, valve size and valve version
- Pressure and temperature of the process medium
- Flow rate in m³/h
- Input signal of the actuator (e.g. 0 to 20 mA or 0 to 10 V)
- Is a strainer installed?
- Installation drawing

EB 5868-1 EN



SAMSON AKTIENGESELLSCHAFT
Weismüllerstraße 3 · 60314 Frankfurt am Main, Germany
Phone: +49 69 4009-0 · Fax: +49 69 4009-1507
samson@samsongroup.com · www.samsongroup.com