

MOUNTING AND OPERATING INSTRUCTIONS



EB 6495-2 EN

Translation of original instructions



TROVIS 6495-2 Industrial Controller

Firmware version 1.11 to 1.21



Edition September 2022

Note on these mounting and operating instructions

These mounting and operating instructions assist you in mounting and operating the device safely. The instructions are binding for handling SAMSON devices. The images shown in these instructions are for illustration purposes only. The actual product may vary.

- For the safe and proper use of these instructions, read them carefully and keep them for later reference.
- If you have any questions about these instructions, contact SAMSON's After-sales Service (aftersalesservice@samsongroup.com).



Documents relating to the device, such as the mounting and operating instructions, are available on our website at www.samsongroup.com > **Service & Support > Downloads > Documentation.**

Definition of signal words

DANGER

Hazardous situations which, if not avoided, will result in death or serious injury

WARNING

Hazardous situations which, if not avoided, could result in death or serious injury

NOTICE

Property damage message or malfunction

Note

Additional information

Tip

Recommended action

1	Safety instructions and measures	1-1
1.1	Notes on possible severe personal injury	1-3
1.2	Notes on possible property damage	1-4
2	Markings on the device	2-1
2.1	Housing inscription	2-1
2.2	Article code	2-2
2.3	Firmware versions	2-2
3	Design and principle of operation	3-1
3.1	Block diagrams	3-4
3.2	Technical data	3-12
3.3	Dimensions	3-16
4	Shipment and on-site transport	4-1
4.1	Accepting the delivered goods	4-1
4.2	Removing the packaging from the industrial controller	4-1
4.3	Transporting the industrial controller	4-1
4.4	Lifting the industrial controller	4-1
4.5	Storing the industrial controller	4-2
5	Installation	5-1
5.1	Installation conditions	5-1
5.2	Preparation for installation	5-1
5.3	Mounting the industrial controller	5-1
5.4	Installing the interface board	5-2
5.5	Electrical connection	5-3
6	Operation	6-1
6.1	Device overview	6-1
6.2	Operating controls	6-3
6.3	Operating structure	6-4
7	Start-up and configuration	7-1
7.1	Configuration	7-1
7.1.1	Entering the configuration menu	7-5
7.1.2	Configuring the controller	7-5
7.1.1.1	Setting configuration items	7-6
7.1.2.1	Configuration example	7-7
7.1.3	Adapting the display direction	7-8
7.1.3.1	Changing the controller display	7-9
7.1.3.2	Setting up additional display	7-11

Contents

7.1.3.3	Switching Controller [1] and Controller [2] displays	7-15
7.2	Configuration using the TROVIS-VIEW software	7-17
7.3	User calibration	7-17
7.3.1	Calibrating analog inputs	7-17
7.3.2	Calibrating analog outputs	7-18
8	Operation	8-1
8.1	Operating level.....	8-1
8.1.1	Adjusting the set point	8-2
8.1.2	Switching over to manual mode and changing the output.....	8-2
8.1.3	Opening/closing cascade	8-3
8.2	Info menu	8-4
8.3	Operating menu	8-8
8.3.1	Entering the operating menu	8-8
8.3.2	Changing the control parameters	8-10
8.3.3	Switching over internal/external set point	8-11
8.3.4	Switching over and changing internal set points	8-12
8.4	Locking the controller	8-14
8.4.1	Locking the operating level	8-14
8.4.2	Locking all keys over a digital input	8-15
8.4.3	Activating key number operation.....	8-16
8.5	Data transmission	8-18
8.5.1	TROVIS-VIEW.....	8-18
8.5.2	Infrared interface	8-19
8.5.3	RS-232/USB interface board	8-19
8.5.3.1	Memory pen.....	8-21
8.5.3.2	Data transmission between the controller and memory pen.....	8-22
8.5.4	RS-485/USB interface board	8-22
9	Malfunctions	9-1
9.1	Troubleshooting	9-1
9.2	Emergency action	9-3
10	Servicing.....	10-1
11	Decommissioning	11-1
12	Removal	12-1
13	Repairs	13-1
13.1	Returning devices to SAMSON	13-1
14	Disposal.....	14-1

15	Certificates	15-1
16	Annex A (configuration guide)	16-1
16.1	Abbreviations	16-1
16.2	Configuration list · Functions and parameters	16-2
17	Annex B	17-1
17.1	Accessories	17-1
17.2	After-sales service	17-2

1 Safety instructions and measures

Intended use

The TROVIS 6495-2 Industrial Controller is a digital controller to automate the industrial and process plants. The controller is suitable for controlling continuous, on/off or pulsing final control elements.

The controller is designed to operate under exactly defined conditions. Therefore, operators must ensure that the controller is only used in operating conditions that meet the specifications used for sizing the controller at the ordering stage. In case operators intend to use the controllers in applications or conditions other than those specified, contact SAMSON.

SAMSON does not assume any liability for damage resulting from the failure to use the device for its intended purpose or for damage caused by external forces or any other external factors.

→ Refer to the technical data for limits and fields of application as well as possible uses. See the 'Design and principle of operation' section.

Reasonably foreseeable misuse

The controller is not suitable for the following applications:

- Use outside the limits defined during sizing and by the technical data

Furthermore, the following activities do not comply with the intended use:

- Use of non-original spare parts
- Performing service and repair work not described

Qualifications of operating personnel

The controller must be mounted, started up, serviced and repaired by fully trained and qualified personnel only; the accepted industry codes and practices must be observed. According to these mounting and operating instructions, trained personnel refers to individuals who are able to judge the work they are assigned to and recognize possible hazards due to their specialized training, their knowledge and experience as well as their knowledge of the applicable standards.

Safety instructions and measures

Personal protective equipment

No personal protective equipment is required for the direct handling of the controller.

Revisions and other modifications

Revisions, conversions or other modifications of the product are not authorized by SAMSON. They are performed at the user's own risk and may lead to safety hazards, for example. Furthermore, the product may no longer meet the requirements for its intended use.

Warning against residual hazards

The controller has a direct effect on the final control element. To avoid personal injury or property damage, plant operators and operating personnel must prevent hazards that could be caused in the control valve by the process medium, the operating pressure, the signal pressure or by moving parts by taking appropriate precautions. Plant operators and operating personnel must observe all hazard statements, warning and caution notes in the referenced documents.

Responsibilities of the operator

Operators are responsible for proper use and compliance with the safety regulations. Operators are obliged to provide these mounting and operating instructions as well as the referenced documents to the operating personnel and to instruct them in proper operation. Furthermore, operators must ensure that operating personnel or third parties are not exposed to any danger.

Responsibilities of operating personnel

Operating personnel must read and understand these mounting and operating instructions as well as the referenced documents and observe the specified hazard statements, warnings and caution notes. Furthermore, operating personnel must be familiar with the applicable health, safety and accident prevention regulations and comply with them.

Referenced standards, directives and regulations

The TROVIS 6495-2 Industrial Controller with a CE marking fulfills the requirements of the Directives 2014/30/EU and 2014/35/EU.

The TROVIS 6495-2 Industrial Controller with an EAC marking fulfills the requirements of the Regulations TR CU 004/2011 and TR CU 020/2011.

The 'Certificates' section contains this declaration of conformity and TR CU certificate.

The controller is designed for use in low voltage installations.

→ For wiring, maintenance and repair, observe the relevant safety regulations.

Referenced documentation

The documentation for the TROVIS 6495-2 Industrial Controller consists of the Mounting and Operating Instructions EB 6495-2 and the Configuration Manual ► KH 6495-2.

These instructions EB 6495-2 describe the installation, electrical wiring and operation of the controller. In addition, EB 6495-2 includes a list of all configuration settings.

The Configuration Manual ► KH 6495-2 describes the controller's functions in detail. The control modes are explained using examples of applications. The TROVIS-VIEW 4 software is explained in detail in the Operating Instructions ► EB 6661.

1.1 Notes on possible severe personal injury

DANGER

Risk of fatal injury due to electric shock.

- Before connecting wiring, performing any work on the device or opening the device, disconnect the supply voltage and protect it against unintentional reconnection. Make sure that the contacts of the digital outputs are voltage-free.
- Only use power interruption devices that can be protected against unintentional reconnection of the power supply.
- Do not remove any covers to perform adjustment work on live parts.

1.2 Notes on possible property damage

! NOTICE

Risk of damage to the controller due to the supply voltage exceeding the permissible tolerances.

The controller is designed for use in low voltage installations.

- Observe the permissible tolerances of the supply voltage.

Controller damage caused by water.

The terminals and the controller housing are not protected against water (terminals: IP 00, housing: IP 30). Only the front panel of the controller is protected against water (IP 65) when installed properly.

- Protect the terminals and the controller housing against drops, sprays and jets of water.

Malfunction due to a configuration that does not meet the requirements of the application.

The controller is configured for specific applications by setting configuration items and parameters. Configuration and parameterization have a direct effect on final control elements.

- Perform the configuration for the specific application.

Manipulation of the configuration due to unauthorized access.

The controller can be protected against unauthorized access through entering a key number.

- Activate key number operation (see the 'Operation' section).
- Do not pass the (service) key number on to unauthorized persons. Keep it in a safe place inaccessible to unauthorized persons.

The operator keys can be protected against unauthorized access over a digital input.

- Lock the operator keys over a digital input (see the 'Operation' section).

2 Markings on the device

2.1 Housing inscription

The details on the device version are lasered onto the nameplate on the side of the industrial controller housing.

The nameplate shown was up to date at the time of publication of this document. The nameplate on the device may differ from the one shown.

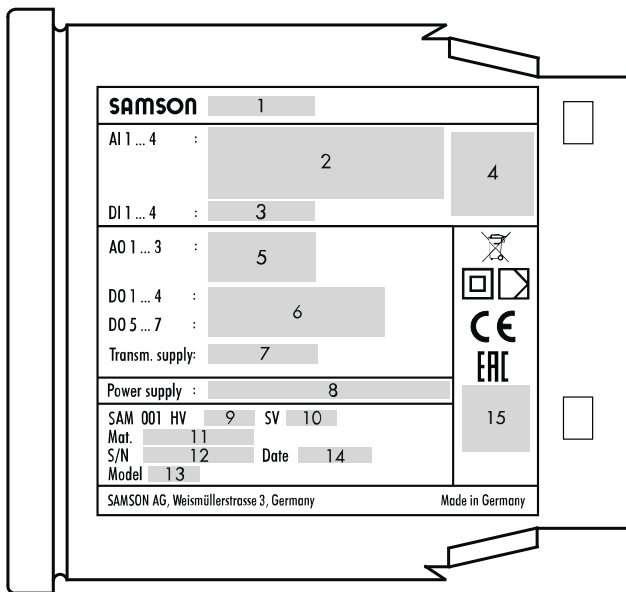

- | | | | |
|---|---|----|--------------------------|
| 1 | Type | 9 | Hardware version |
| 2 | Analog inputs 1 to 4 | 10 | Software version |
| 3 | Digital inputs 1 to 4 | 11 | Material no. |
| 4 | Data Matrix code | 12 | Serial number |
| 5 | Analog outputs 1 to 3 | 13 | Model number |
| 6 | Digital outputs 1 to 7 | 14 | Date of manufacture |
| 7 | Two-wire transmitter supply | 15 | Other mark of conformity |
| 8 | Supply voltage, power line frequency, power consumption | | |

2.1 Article code

TROVIS 6495-2 Industrial Controller x

Supply voltage	
85 to 264 V AC	1
24 V AC/DC	2

2.1 Firmware versions

Firmware revisions	
Old	New
1.11.064	1.11.066 (09-2009)
	O.1.6 'Constant output value 1 with DI' now also functions in combination with C.4.1-6 'Operation mode after restart, Manual, start AO = AO.K1'. In firmware version 1.11.066, the use of 1.C.2.2.3-1 to 1.C.2.2.3-4 'Open cascade with DI' results in a memory error. These functions must not be configured.
1.11.066	1.11.068 (06-2011)
	In firmware version 1.11.068, the error after the use of 1.C.2.2.3-1 to 1.C.2.2.3-4 'Open cascade with DI' is rectified. In addition, the MSP now has a voltage monitor to ensure that data is not lost after a power voltage failure.
1.11.068	1.11.070 (06-2012)
	In firmware version 1.11.070, the communication parameters 'Station number', 'Transmission rate', 'Parity' and 'Stop bit' remain saved after a warm or cold start.
1.11.070	1.21.027 (06-2015)
	The firmware version 1.21 has a 50 ms scanning time, making it twice as fast and better suited for fast control systems. We recommend updating the controller to firmware version 1.21. By performing the update using one of the optional plug-in interface boards, device settings remain saved. Note on updating to firmware version 1.21: if feedforward control to YPID was configured with C.3.2.3-3 and C.3.2.9, note that disturbance variable B no longer refers to the measuring range of PV; it is now calculated without reference to the measuring range.

Firmware revisions	
Old	New
1.11.070	<p>The following section references refer to the Configuration Manual ► KH 6495-2)</p> <p>Section C.3.1.3 Error signal:</p> <ul style="list-style-type: none"> - E.TZ Operating threshold [0.00 to 110.00 %], firmware version 1.11 and lower [0.0 to 110.0 %] <p>Section C.3.2.9 Arithmetic operation output YPID:</p> <ul style="list-style-type: none"> - In firmware version 1.21 and higher, the disturbance variable B is linked to YPID over C.3.2.9 as an unscaled value. In firmware version 1.11 and lower, the disturbance variable B, scaled according to the measuring range of PV, is linked to the output signal YPID of the control algorithm over C.3.2.9. <p>Section D Communication data point list:</p> <ul style="list-style-type: none"> - AI1 to AI4, PV, PVO, SPE, DV, TR, FB: in firmware version 1.21 and higher, it is transferred as a physical value (unscaled). In firmware version 1.11 and lower, it is transferred as a percentage in relation to the measuring range. <p>Section D Communication data point list:</p> <ul style="list-style-type: none"> - Output Y can be written in manual mode and only read in automatic mode in firmware version 1.21 and higher. It can only be read in firmware version 1.11 and lower. <p>Section D Communication data point list:</p> <ul style="list-style-type: none"> - Manual/automatic, internal/external set point, open/close cascade can be written and read in firmware version 1.21 and higher. They can only be read in firmware version 1.11 and lower. <p>Section D Communication data point list:</p> <ul style="list-style-type: none"> - Internal set point (0)/external set point (1) in firmware version 1.11 and lower, action reversed: internal (1), external (0) <p>Section D Communication data point list:</p> <ul style="list-style-type: none"> - Internal/external set point can be written in firmware version 1.21 and higher if the function is not switched by a digital input. <p>Section D Communication data point list:</p> <ul style="list-style-type: none"> - The internal set points can be switched over the Modbus holding register HR 55 (Controller [1]) und HR 115 (Controller [2]) in firmware version 1.21 and higher. <p>Section C.2.3.1 Set point ramp, wait condition:</p> <ul style="list-style-type: none"> - Monitoring of deviation band SP.RH only has a one-sided effect in firmware version 1.21 and higher. Additionally the range of the deviation band [0.1 to 1000.0 %] and the default setting 1000.0 % have been changed (in firmware version 1.11 and lower: [0.1 to 100.0 %] and 100.0 % respectively)

Markings on the device

Firmware revisions	
Old	New
1.11.070	Section D.1.1 Communication monitoring: <ul style="list-style-type: none">– An entry is made in the error list and event list in the event of timeout in firmware version 1.21 and higher. The fault indication icon  is also indicated in the display.– Changing the configuration of the input signal source in the I.x.1 configuration item does not cause the measuring range to be reset any more in firmware version 1.21 and higher.
1.21.027	1.21.030 (10-2015) <p>The output of the input variables PV, PV0, DV, SPE, TR, FB and SPO to the outputs AOx is scaled again to the associated measuring range (in comparison to firmware version 1.21.027).</p> <p>The limitation of YM in a cascade controller now also has an effect on the controller output Y.</p>

3 Design and principle of operation

The TROVIS 6495-2 Industrial Controller has two independently working controllers with shared input and output sections.

By setting the functions and parameters, the controller can be adapted to a control task quickly. Preset basic configurations for each control type minimize setup work for standard applications. The controller can be set up using the keys on the housing or the optional TROVIS-VIEW software without requiring any additional accessories.

i Note

TROVIS-VIEW provides a uniform user interface that allows users to configure and parameterize various SAMSON devices using device-specific database modules. The device module for TROVIS 6495-2 can be downloaded free of charge from our website at www.samsongroup.com > Services > Software > TROVIS-VIEW. Further information on TROVIS-VIEW (e.g. system requirements) is available on our website and in the Data Sheet ► T 6661.

The controller settings are saved in a non-volatile memory, even when the power supply fails. The two internal controllers can be operated directly without switching. The plain-text display in English, German and French facilitates configuration and parameterization.

Control modes

- Fixed set point control, one or two channels, internal/external switchover
- Follow-up control, one or two channels, internal/external switchover
- Ratio control (mixing control)
- Cascade control, consisting of master and slave controller
- Limiting or override control

Control

- Linking of input variables (addition, subtraction, multiplication, division, mean value, minimum and maximum selection) for feedforward control or control with one to four input variables (multi-component control)
- Operation with up to four internal set points and one external set point, either analog or via interface (SPC mode)
- Set point ramp and output ramp
- Split-range operation
- Control mode selection P/PI or PD/PID
- KP and TN adapted using the controlled variable, reference variable, manipulated variable or error signal
- Adjustable limitation of integral-action component
- Operating point preset by set point or digital input
- Control signal limitation (fixed or floating according to an input variable)
- Operation with code number or key locking by a digital input

Design and principle of operation

Inputs

– 4 analog inputs (AI1 to AI4)

DIP switches at the side of the housing to select current or resistance inputs. The signal type is set depending on the configuration:

- 0/4 to 20 mA
- 0/2 to 10 V
- Pt 100 or Pt 1000 resistance thermometer
- Filter, root extraction, function generation and measuring range monitoring
- Input 2 additionally for potentiometers

– 4 digital inputs (DI1 to DI4)

The digital inputs are controlled either by a 24 V DC voltage signal or by the transmitter supply using a floating contact. The digital outputs can only be controlled in groups, with DI1 and DI2 being the first group and DI3 and DI4 being the second group.

Example: internal supply for digital inputs DI1 and DI2 and external supply for digital inputs DI3 and DI4.

- Set point switchover, constant output value, reversal of operating action, output tracking (DDC backup), ramps etc

The following functions that have been defined over the C Controller, O Output and A General settings menus can be assigned to a digital input (see the 'Start-up and configuration' section):

- Invert digital input
- Switchover between internal set points
- Switchover to external set point
- Open/close cascade
- Incremental/decremental set point change
- Set point increase/decrease by constant
- Start set point ramp
- Hold set point ramp
- Invert error signal
- Control mode selection P(D)/PI(D)
- Activate operating point for P/PD controller
- Manual/automatic switchover
- Hold output
- Activate output tracking
- Increase/decrease actual value
- Activate constant output value
- Start output ramp
- Limit output rate
- Lock control keys

Outputs

– 3 analog outputs (AO1 to AO3)

The signal type is set depending on the configuration.

- 0/4 to 20 mA
- 0/2 to 10 V

The outputs AO1 to AO3 can optionally be used for other signals as well.

- **7 digital outputs (4 relay outputs and 3 transistor outputs)**

The relay outputs can be used as follows:

- SO1 and SO2 as on/off or three-step output
 - DO1 to DO4 as limit output
 - DO5 and DO6 (transistor output) for status messages
 - DO7 (transistor output) for fault alarms
- **4 relay outputs**
for two on/off or three-step outputs or four limit alarms
 - **2 transistor outputs**
for status messages
 - **1 transistor output**
for fault alarms
 - **One supply output**

The supply output can be used to supply a voltage for up to 4 two-wire transmitters and 4 digital inputs (21 V DC, max. 90 mA).

Infrared interface

Data are transmitted between the controller and the TROVIS-VIEW software over an infrared interface, by default integrated into the controller and an infrared adapter (order no. 8864-0900) connected to a computer (see the 'Operation' section).

Communication interface

Optionally, the controller can be equipped with one of the following interface boards. The boards can also be retrofitted.

- **RS-232/USB interface board**

- One RS-232 interface with RJ-12 jack
- One USB interface with 5-pin mini-B port

The RS-232 data transfer uses an SSP or Modbus RTU protocol. The memory pen-64 can be used with controllers fitted with an RS-232/USB interface board to load data configured in TROVIS-VIEW or transferred from another controller.

- **RS-485/USB interface board**

- RS-485 interface (4 terminals) and
- USB interface (5-pin mini-B port)

The RS-485 data transfer uses an SSP or Modbus RTU protocol. Slide switches are used to set the two-/four-wire operation and to activate bus termination.

Design and principle of operation

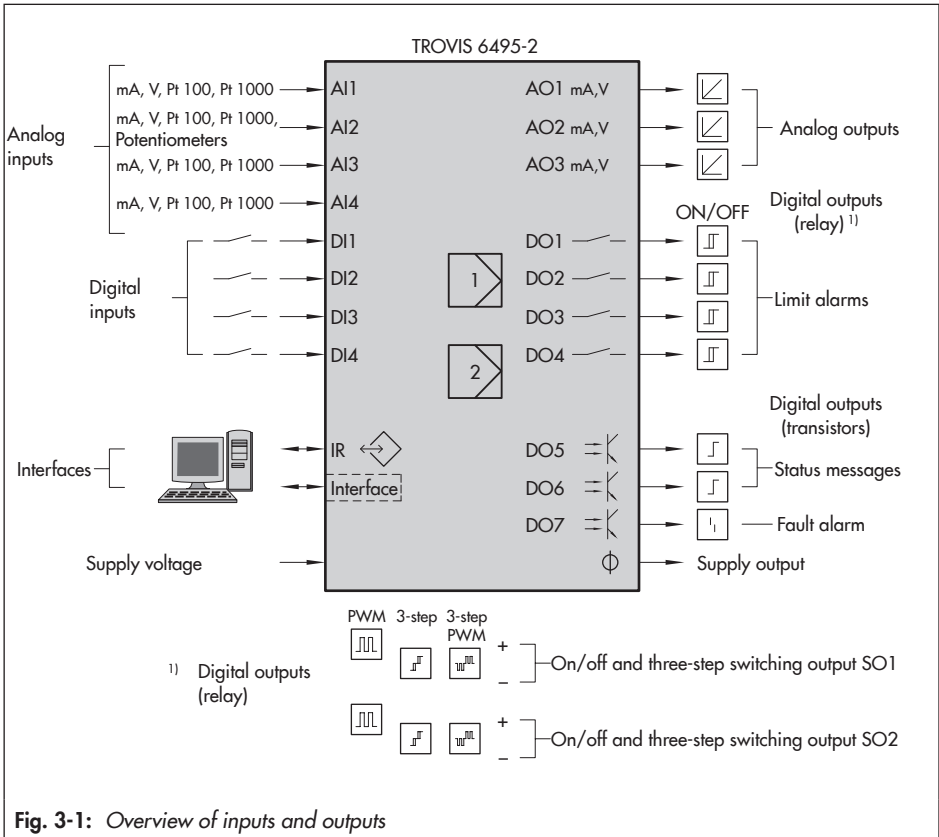
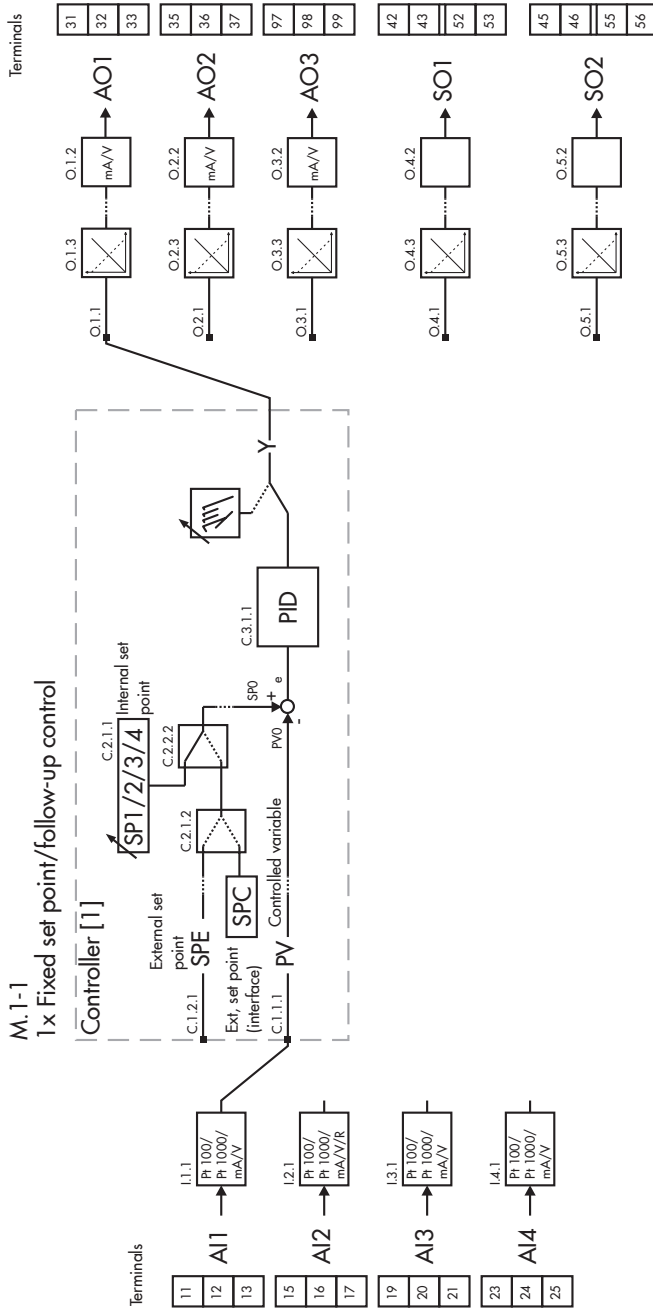

Fig. 3-1: Overview of inputs and outputs

3.1 Block diagrams

Simplified block diagrams are shown for each control mode on the following pages. The Configuration Manual ► KH 6495-2 contains detailed block diagrams.



Design and principle of operation

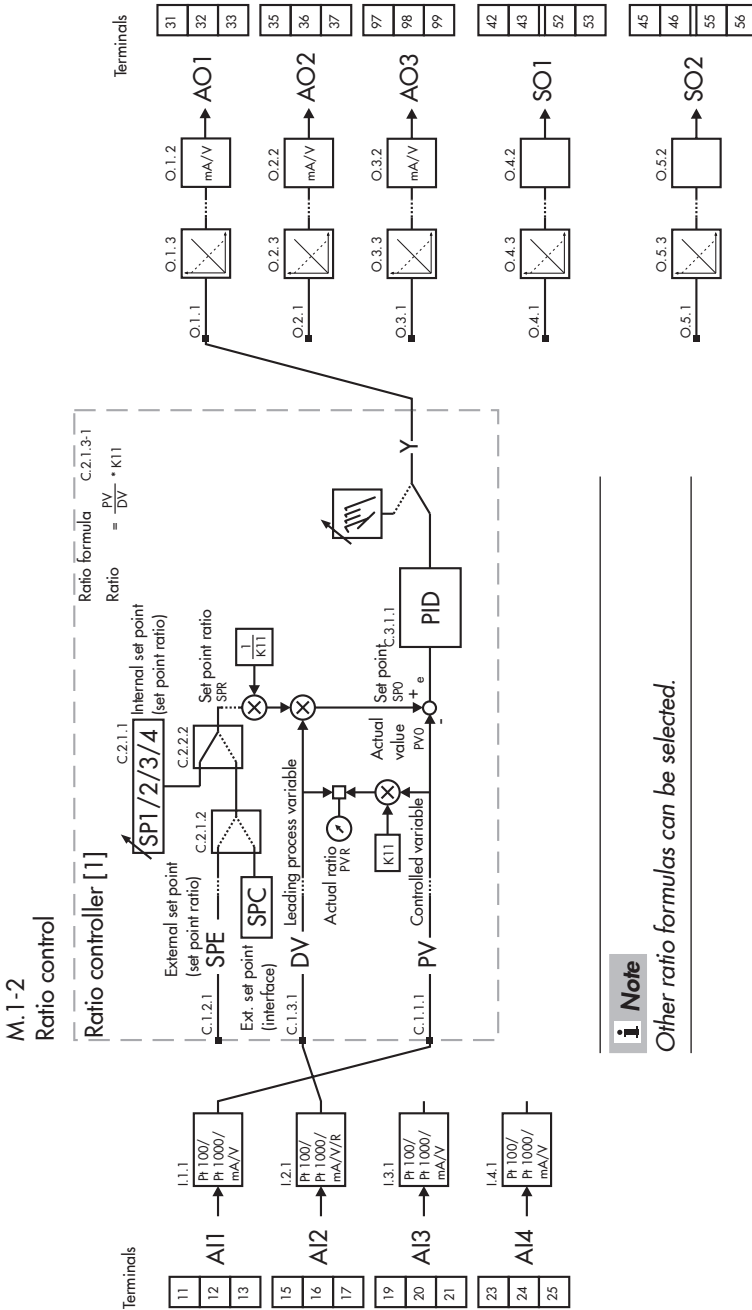

Note

Other ratio formulas can be selected.

M.1-2
Ratio control

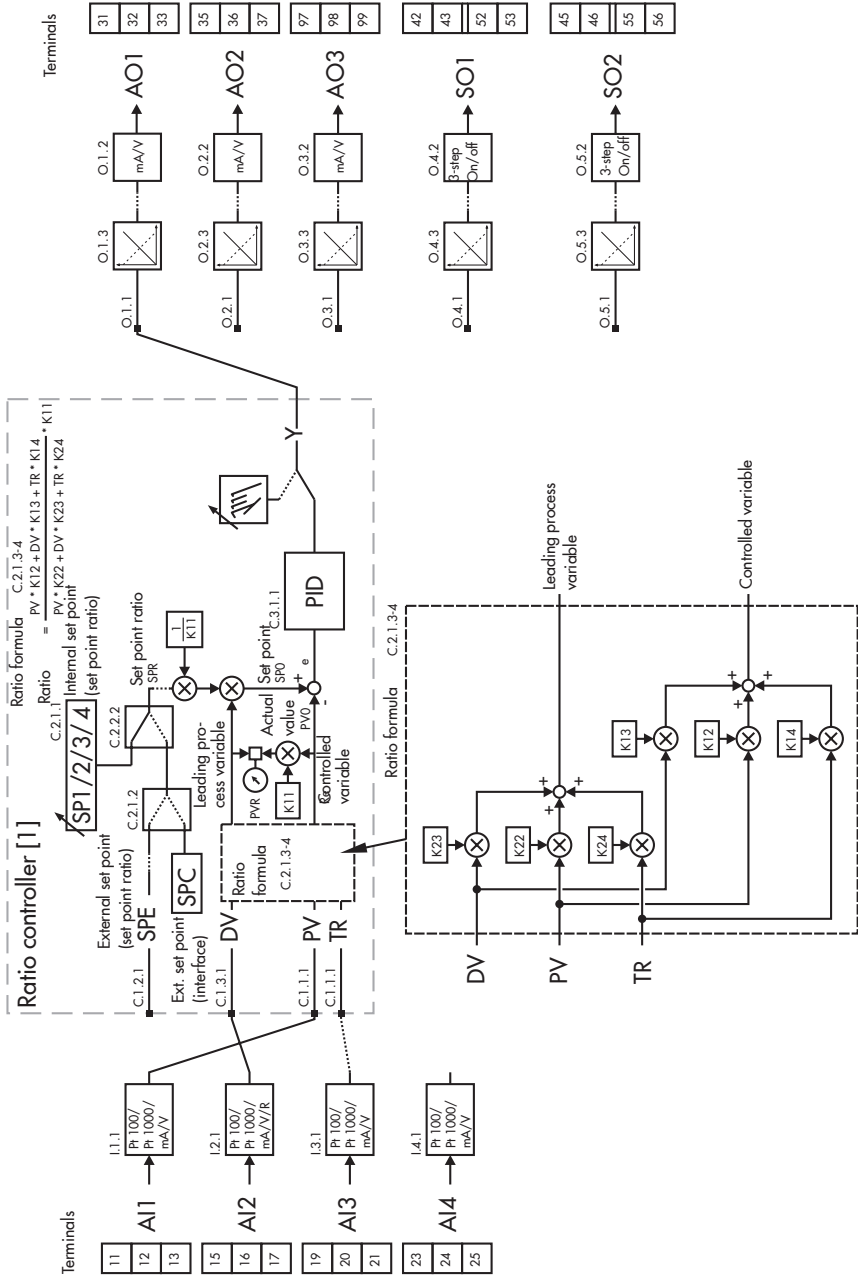

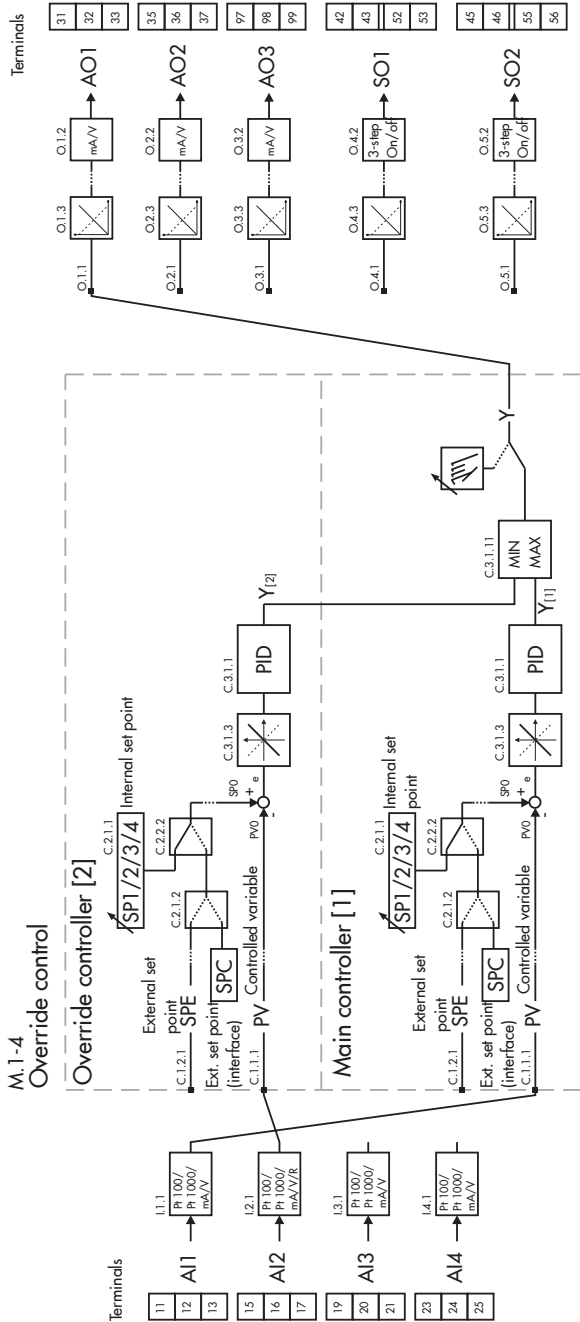

Design and principle of operation

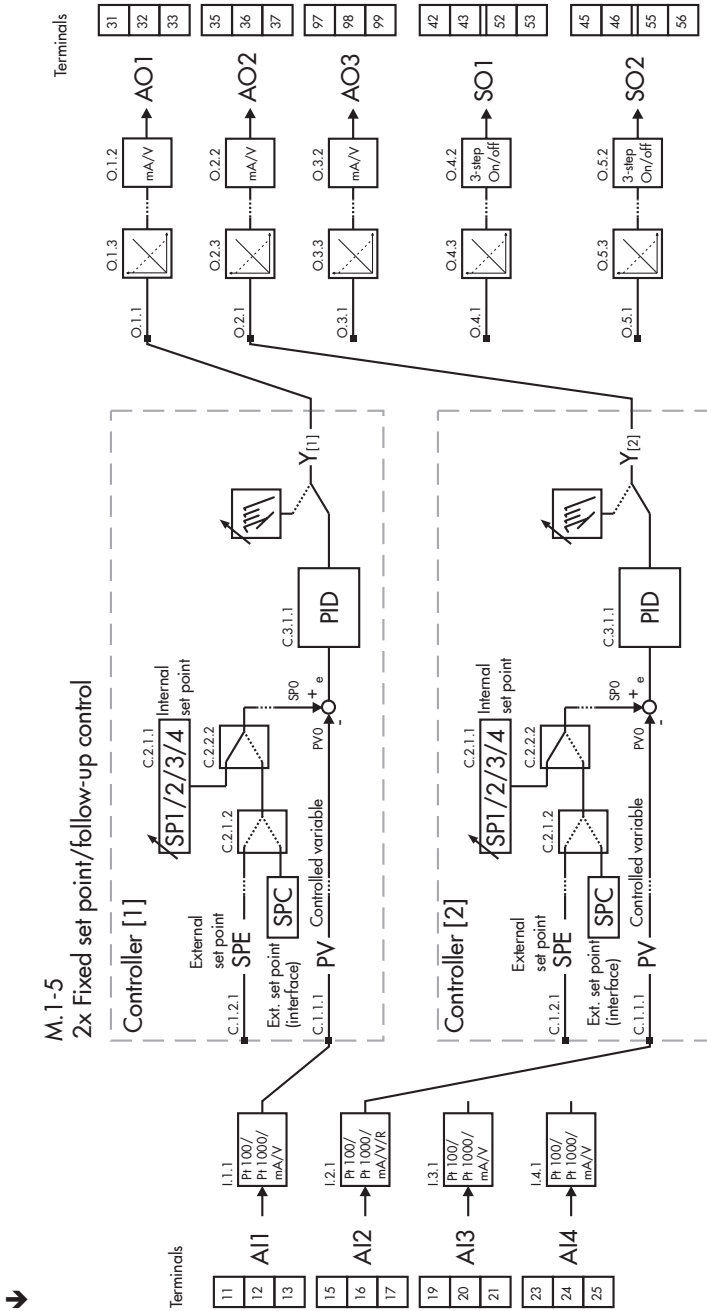

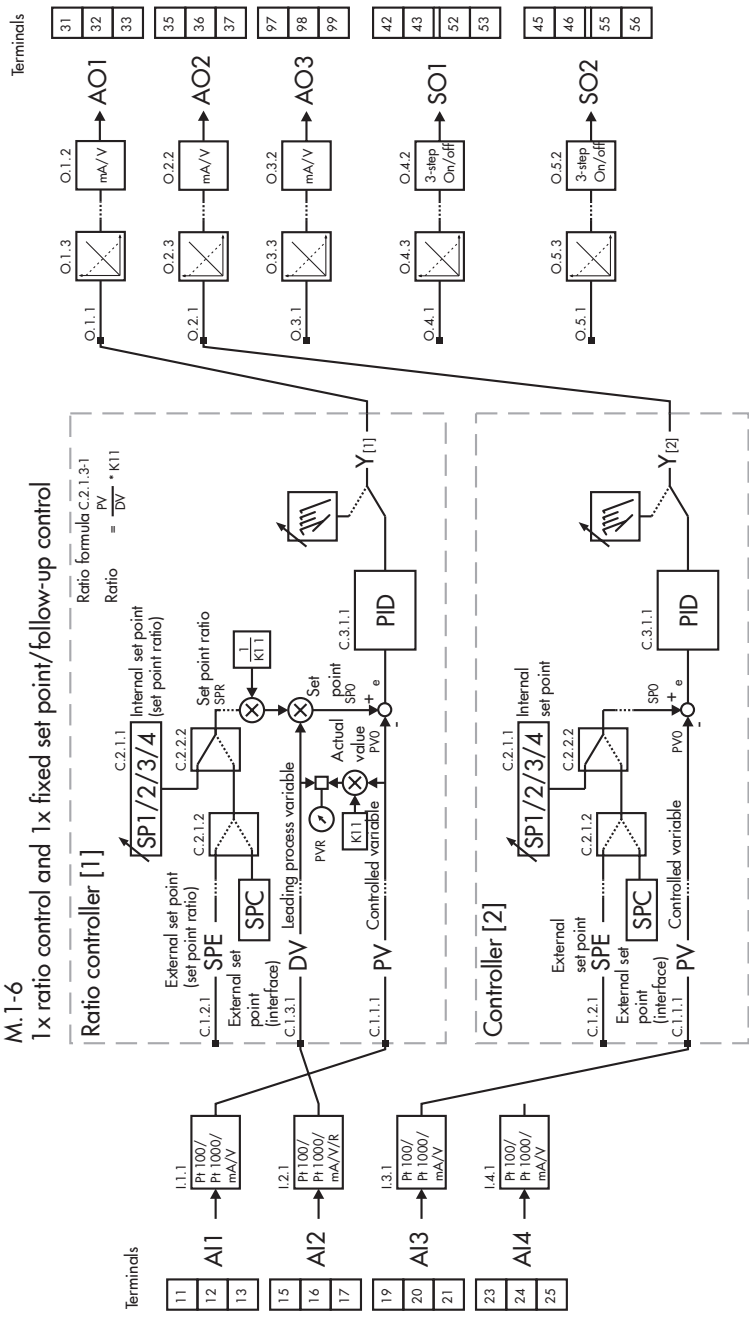

i Note

Further ratio formulas are can be selected for ratio controller [1].

3.2 Technical data

Table 3-1: Technical data · TROVIS 6495-2

Inputs		
4 analog inputs		mA, V, Pt 100, Pt 1000, input 2 also for resistance transmitter (potentiometer)
Current or voltage inputs	Version	Differential input
	Nominal signal range	0 to 20 mA, 4 to 20 mA, 0 to 10 V, 2 to 10 V
	Resolution	<0.007 %, relating to nominal signal range
	Permissible signal range	-1 to +22 mA or -0.5 to +11 V
	Input resistance	50 Ω (current); 10 k Ω (voltage)
	Static destruction limit	\pm 50 mA (current); \pm 30 V (voltage)
Resistance thermometer	For sensor	Pt 100, Pt 1000, according to DIN EN 60751
	Nominal signal range	-50 to +300 $^{\circ}$ C (-58 to +572 $^{\circ}$ F)
	Connection	Three-wire connection (resistance of each line <15 Ω), two-wire circuit
	Resolution	<0.02 K (<0.006 % relating to nominal signal range)
Resistance transmitters (potentiometers)	Nominal values	100, 200, 500, 1000 Ω
	Connection	Three-wire connection (resistance of each line <15 Ω)
	Resolution	<0.006 %
General specifications	Measuring error of inputs for zero, span, linearity	< \pm 0.2 % of nominal signal range
	Ambient temperature influence	< \pm 0.1 %/10 K for zero and span (based on 20 $^{\circ}$ C)
	Input filter	Adjustable
	Function generation	Adjustable using 7 points
	Signal increase/drop	Adjustable
	User calibration	Adjustable
	Transmitter fault alarm	Adjustable, input signal <- \square 5 % or >105 %
	Transmitter supply	21 V DC, max. 90 mA, resistant to short circuit

4 digital inputs		
	Actuation	Floating switching contact or external switching voltage 24 V DC, 3 mA; sets of two digital inputs are galvanically connected on one side Signal state OFF: 0 to 10 V Signal state ON: 17 to 31 V Signal inversion adjustable
Outputs		
3 analog outputs		
	Nominal signal range	0 to 20 mA, 4 to 20 mA, 0 to 10 V, 2 to 10 V
	Max. permissible signal range	0 (2.4) to 22 mA or 0 (1.2) to 11 V
	Load	<750 Ω for current; >3 k Ω for voltage
	Error of outputs	< ± 0.2 % of nominal signal range for zero, span, linearity
	Ambient temperature influence	< ± 0.1 %/10 K for zero and span (based on 20 °C)
	Resolution	<0.03 %, relating to nominal signal range
	Static destruction limit	± 30 V
7 digital outputs		
		4 relays with floating closing contact (NO), can be inverted
	Relays	Permissible contact load
		264 V AC, 1 A AC, $\cos \phi = 1$ or 250 V DC, 0.1 A DC
		Spark suppression
		Connected in series C = 2.2 nF and varistor 300 V AC, in parallel to each relay contact
	Transistor outputs	3 electrically isolated transistor outputs
		External supply
		3 to 42 V DC, max. 30 mA
Interfaces		
		Transmission protocol
		SAMSON-specific protocol (SSP)
		Data that can be transmitted
		Controller settings, process variables, operating status
	Infrared interface	Transmission rate
		9600 bit/s
		Angle of reflected beam
		50°
		Distance between infrared adapter and controller
		≤ 70 cm

Design and principle of operation

RS-232/USB (accessories)	RS-232 with electrical insulation, USB (slave)		
	Connection	USB: 5-pin mini-B	
		RS-232: RJ-12	
	Transmission protocol	USB: SAMSON-specific protocol (SSP)	
RS-232: SSP and Modbus RTU			
Data that can be transmitted	Controller settings, process variables, operating status, fault alarms		
RS-485/USB (accessories)	RS-485 with electrical insulation, USB (slave)		
	Connection	USB: 5-pin mini-B	
		RS-485: 4-pin screw terminals	
	Transmission protocol	USB: SAMSON-specific protocol (SSP)	
		RS-485: SSP and Modbus RTU	
	Data that can be transmitted	Controller settings, process variables, operating status, fault alarms	
	Transmission rate/ format	SSP: 9600 bit/s, 8 Bit, no parity bit, 1 stop bit	
		Modbus: 300 to 115200 bit/s, 8 bit, parity bit adjustable, 1 (2) stop bits	
	Type of transmission	RS-485: Asynchronous, half duplex, four-wire or two-wire	
	Number of connected devices	RS-485: 32 (can be extended when repeater is used)	
	Number of addressable stations	Modbus: 246	
Cable length	RS-485: <1200 m; max. 4800 m with repeater		
RS-485 bus termination	Active, selectable		
Transmission medium	RS-485: 2 or 4 cores (twisted pair cable, stranded in pairs, with static shield)		
General specifications			
Supply voltage	85 to 264 V AC, 47 to 63 Hz or 24 V AC/DC (20 to 30 V), 47 to 63 Hz		
Power consumption	85 to 264 V AC	Max. 19 VA, external fuse >630 mA (slow)	
	20 to 30 V AC/DC	Max. 15 VA, external fuse >1.25 mA (slow)	
Perm. temperature range	Ambient	0 to 50 °C	
	Storage	-20 to +70 °C	
Relative humidity	Max. 95 %, non-condensing		

Degree of protection	IP 65 (front), IP 30 (housing), IP 00 (terminals) according to EN 60529
Device safety	According to EN 61010-1: Protection class II, overvoltage category II, degree of contamination 2
Electromagnetic compatibility	Requirements according to EN 61000-6-2, EN 61000-6-3 and EN 61326-1
Mechanical environmental influences affecting storage, transport and operation	Sinusoidal vibration according to IEC 60068-2-6: 2 to 9 Hz; 3.5 mm amplitude 9 to 200 Hz; 10 m/s ² acceleration 200 to 500 Hz; 15 m/s ² acceleration Random and guidance vibration according to IEC 60068-2-64: 1.0 m ² /s ³ ; 10 to 200 Hz 0.3 m ² /s ³ ; 200 to 2000 Hz Shocks according to IEC 60068-2-27: Acceleration 100 m/s ² ; duration 11 ms
Electrical connection	Screw terminals 1.5 mm ² (0.5 to 1.5 mm ² wire cross-section)
Display	Dot matrix display with 132x49 pixels
Display range	-999 to 9999; start value, end value and decimal separator can be adjusted
Cycle time	50 ms (firmware version 1.11 and lower: 100 ms)
Configuration	Functions saved in read-only memory, configuration saved in non-volatile memory
Control modes	One or two fixed set point/follow-up control One ratio control One cascade control One ratio and fixed set point/follow-up control One override control
Weight	0.5 kg
Conformity	

3.3 Dimensions

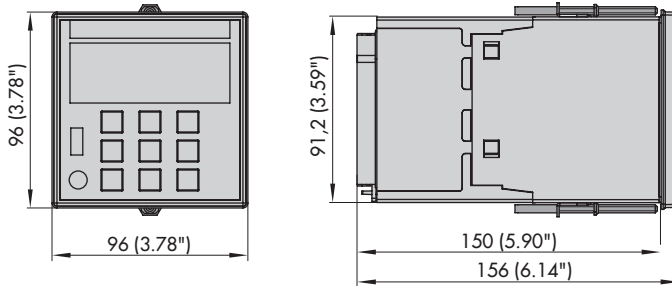

Fig. 3-2: Dimensions in mm (inch)

4 Shipment and on-site transport

The work described in this section is only to be performed by personnel appropriately qualified to carry out such tasks.

4.1 Accepting the delivered goods

After receiving the shipment, proceed as follows:

1. Compare the shipment received with the delivery note.
2. Check the shipment for transportation damage. Report any damage to SAMSON and the forwarding agent (refer to delivery note).

4.2 Removing the packaging from the industrial controller

i Note

Do not remove the packaging until immediately before mounting and start-up.

1. Remove the packaging from the industrial controller.
2. Check scope of delivery (see Fig. 4-1).
3. Dispose and recycle the packaging in accordance with the local regulations.

1x	TROVIS 6495-2 Industrial Controller
1x	Accessories
1x	Seal
1x	14-pole screw terminal
1x	15-pole screw terminal
1x	6-pole screw terminal
1x	2-pole screw terminal
1x	8-pole screw terminal
2x	Mounting clamp
2x	Adhesive label kit
1x	Document IP 6495-2 (Important Product Information)

Fig. 4-1: *Scope of delivery*

4.3 Transporting the industrial controller

Transport instructions

- Protect the industrial controller against external influences (e.g. impact).
- Protect the industrial controller against moisture and dirt.
- Observe transport temperature depending on the permissible ambient temperature from -20 to $+70$ °C (see the 'Design and principle of operation' section).

4.4 Lifting the industrial controller

Due to the low service weight, lifting equipment is not required to lift the industrial controller.

4.5 Storing the industrial controller

! NOTICE

Risk of controller damage due to improper storage.

- *Observe the storage instructions.*
 - *Avoid long storage times.*
 - *Contact SAMSON in case of different storage conditions.*
-

i Note

We recommend regularly checking the industrial controller and the prevailing storage conditions during long storage periods.

Storage instructions

- Protect the industrial controller against external influences (e.g. impact).
- Protect the industrial controller against moisture and dirt. In damp spaces, prevent condensation. If necessary, use a drying agent or heating.
- Make sure that the ambient air is free of acids or other corrosive media.
- Observe transport temperature depending on the permissible ambient temperature from -20 to $+70$ °C (see the 'Design and principle of operation' section).
- Do not place any objects on the industrial controller.

5 Installation

The work described in this section is only to be performed by personnel appropriately qualified to carry out such tasks.

5.1 Installation conditions

Work position

The work position for the industrial controller is the front view onto the operating controls on the controller seen from the position of operating personnel.

Operators must ensure that, after installation of the industrial controller, the operating personnel can perform all necessary work safely and easily access the controller from the work position.

5.2 Preparation for installation

Before installation, make sure the following conditions are met:

- The industrial controller is not damaged.

Proceed as follows:

- ➔ Lay out the necessary material and tools to have them ready during installation work.

5.3 Mounting the industrial controller

The TROVIS 6495-2 Industrial Controller is designed for panel mounting (see Fig. 5-2 and the 'Design and principle of operation' section).

i Note

When installing several TROVIS 6495-2 Industrial Controllers, keep the minimum distance between each controller (see Fig. 5-2).

1. Make a panel cut-out with the dimensions $92^{+0.8} \times 92^{+0.8}$ mm.
 2. Push the industrial controller into the panel cut-out from the front.
 3. Insert the mounting clamps into the top and bottom recesses.
 4. Turn threaded rods towards the panel using a screwdriver, clamping the housing against the panel.
-

! NOTICE

The IP rating will be lower if the controller is not fastened properly.

- ➔ *Tighten the threaded rods far enough to ensure the specified IP rating is achieved.*
-

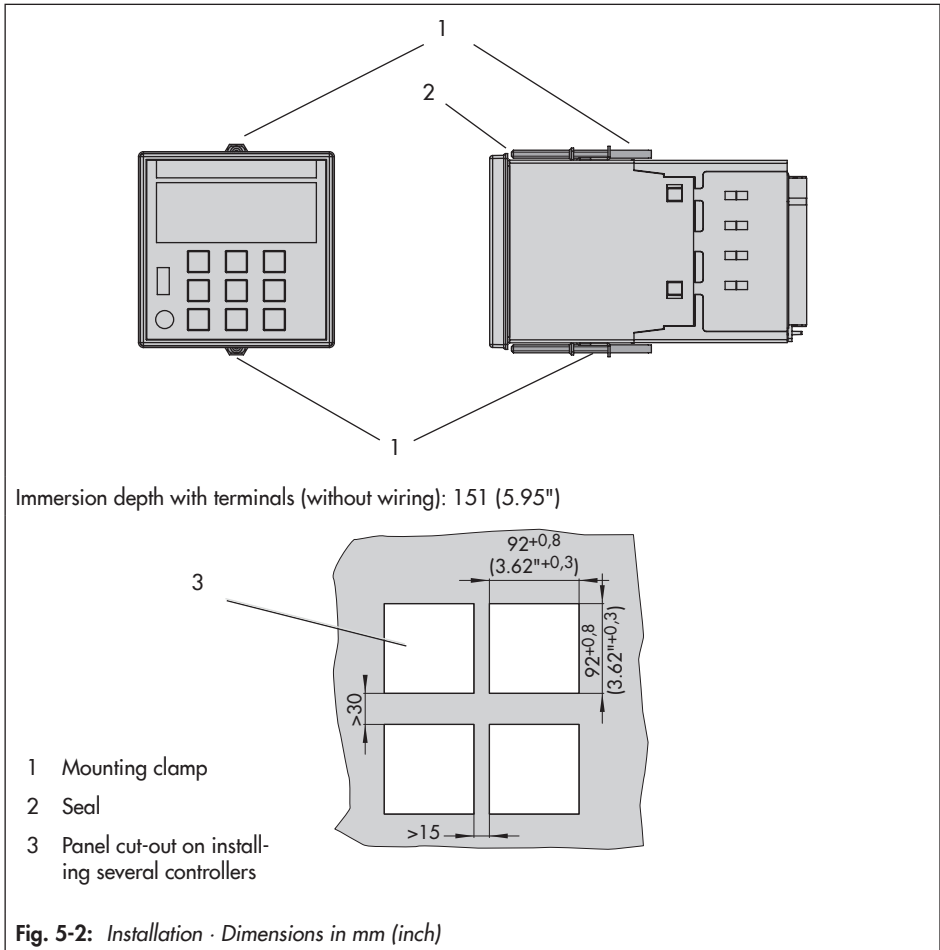

5.4 Installing the interface board

For operation of the controller with one of the two interface boards:

The interface board is fitted at the back of the controller.

1. Switch off the supply voltage.
2. Press the two catches on the blank cover inwards at the same time. Pull out the blank cover.
3. Push the interface board with cover into the opening, making sure that the interface board is inserted in the guide

rails intended for it and that the cover engages.

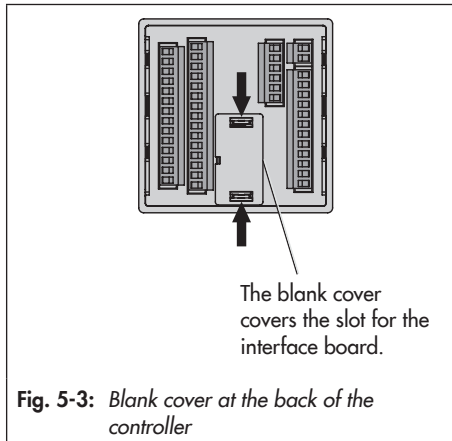

5.5 Electrical connection

⚠ DANGER

Risk of fatal injury due to electric shock.

→ For electrical installation, you are required to observe the relevant electro-technical regulations of the country of use as well as the regulations of the local power suppliers.

Therefore, such work must be performed by trained and experienced personnel.

→ Do not connect ELV cables (according to VDE 0100) to these terminals.

→ Before performing any work on the terminals, disconnect the voltage supply from the industrial controller.

Notes on electric wiring

- Install the power supply lines and the signal lines separately. Do not install them parallel to each other.
 - To improve noise immunity, observe a minimum distance of 10 cm between the power line and the measuring input line.
 - To avoid measurement errors or other disturbances, use shielded cables for the analog and binary signal lines. Ground the shield at one side, either at the control cabinet inlet or outlet, using the largest possible cross-section.
 - Connect the central grounding point and the PE grounding conductor with a cable with $\geq 10 \text{ mm}^2$ wire cross-section using the shortest route.
 - Inductances in the control cabinet, e.g. contactor coils, must be equipped with suitable interference suppressors (RC elements).
 - Control cabinet elements with high field strength, e.g. transformers or frequency converters, must be shielded with separators providing a good ground connection.
- The industrial controller has plug-on screw terminals for lines with a wire cross-section from 0.5 to 1.5 mm². Connect the lines to the terminal blocks 1 and 4 (see Fig. 5-5, Fig. 5-6 and Fig. 5-7).
- Plug the plug-on screw terminals securely into the appropriate connector sockets in the controller.

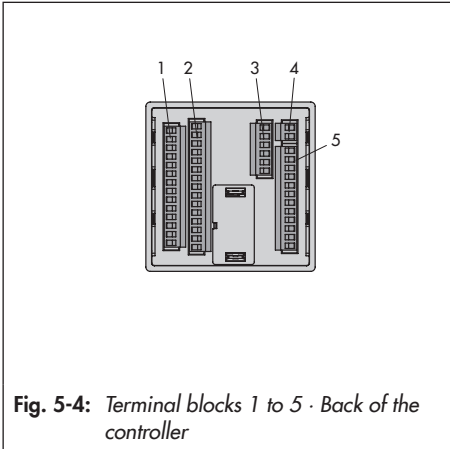

Fig. 5-4: Terminal blocks 1 to 5 · Back of the controller

Transmitter supply

The controller has a supply output to power a maximum of four two-wire transmitters (21 V DC, 90 mA).

Resistance thermometer

The analog inputs AI1 to AI4 are designed for the connection of resistance thermometers Pt 100 and Pt 1000 in a three-wire circuit. The resistance of each connection lead must be the same and not exceed 15 Ω . It is not necessary to calibrate the line.

Resistance thermometers can also be connected in two-wire circuits. In this case, connect a jumper between the controller terminals. Take into account that the lead resistance may reach several ohms over long distances, causing the measured value to be considerably distorted. This measured value can be balanced out using a correction value (I.1.4/I.2.4/I.3.4/I.4.4 Input signal increase/decrease configuration item, see Annex A).

Potentiometers

The analog input AI2 is designed for the connection of a potentiometer with two-wire or three-wire connection. Potentiometers between 50 and 1200 Ω can be connected.

A potentiometer is used, for example for position feedback of an electrical actuator or for input of an external set point.

i Note

Generally, we recommend performing a user calibration. To perform a calibration, use A.20.2.13 (zero) and A.20.2.14 (end) configuration items (see the 'Start-up and configuration' section).

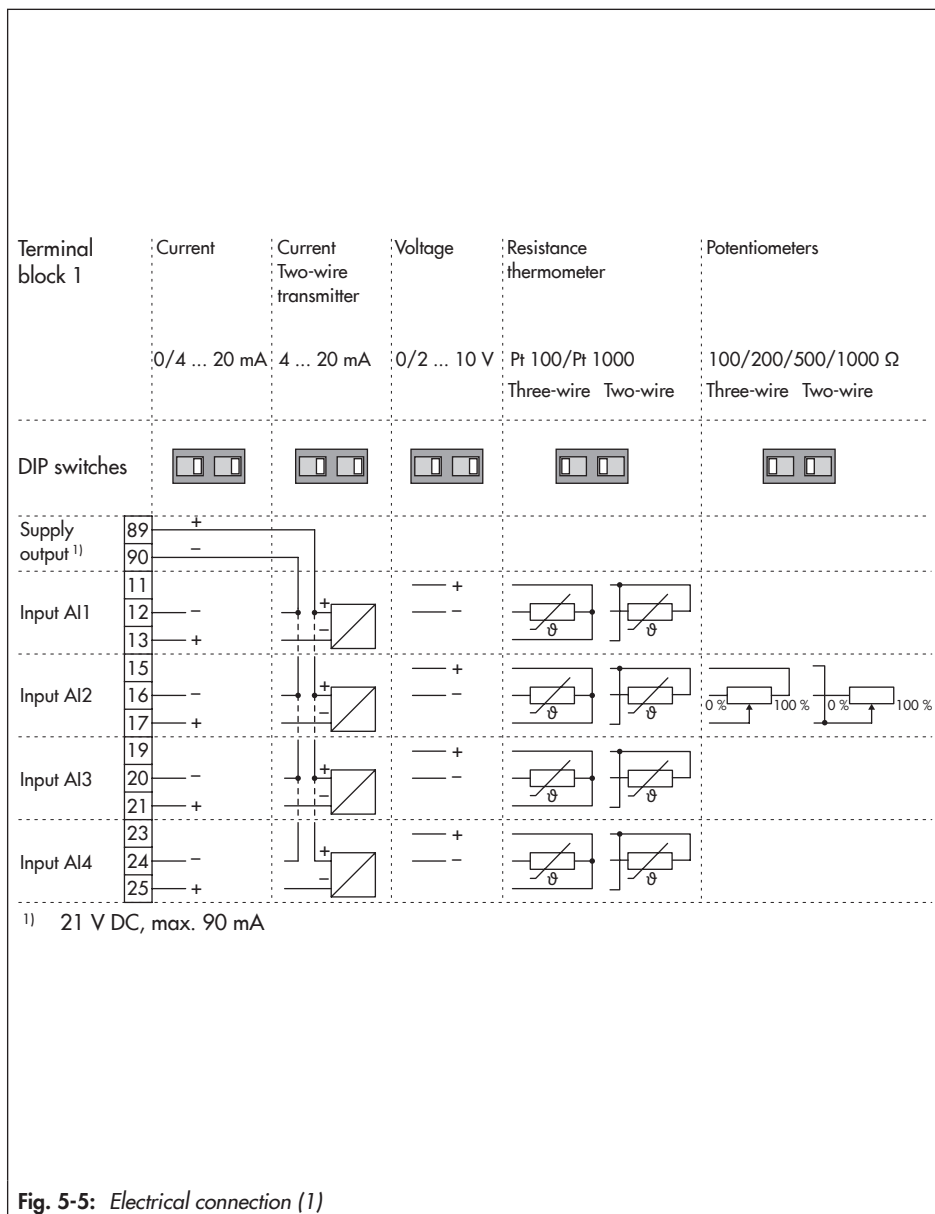
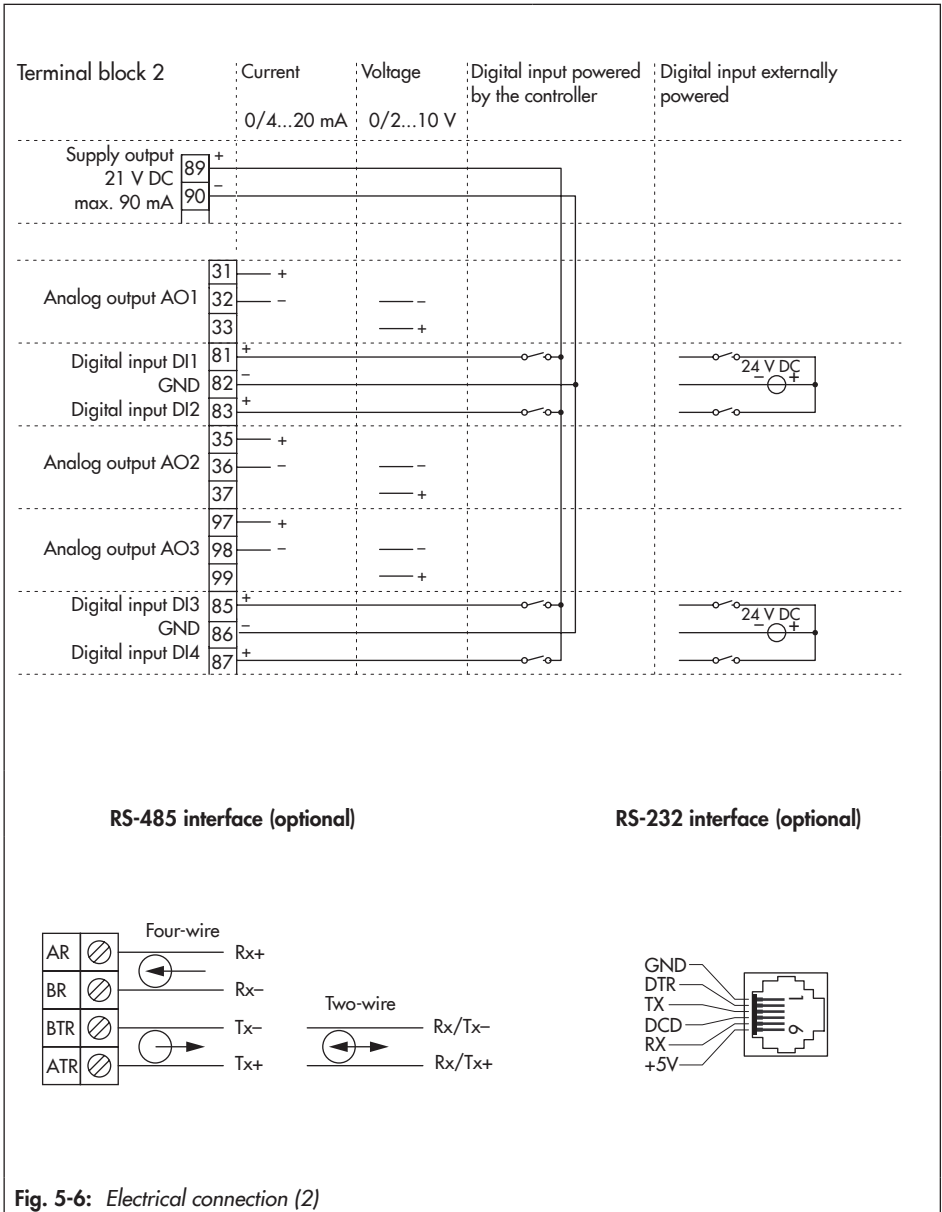

Fig. 5-5: Electrical connection (1)

Installation



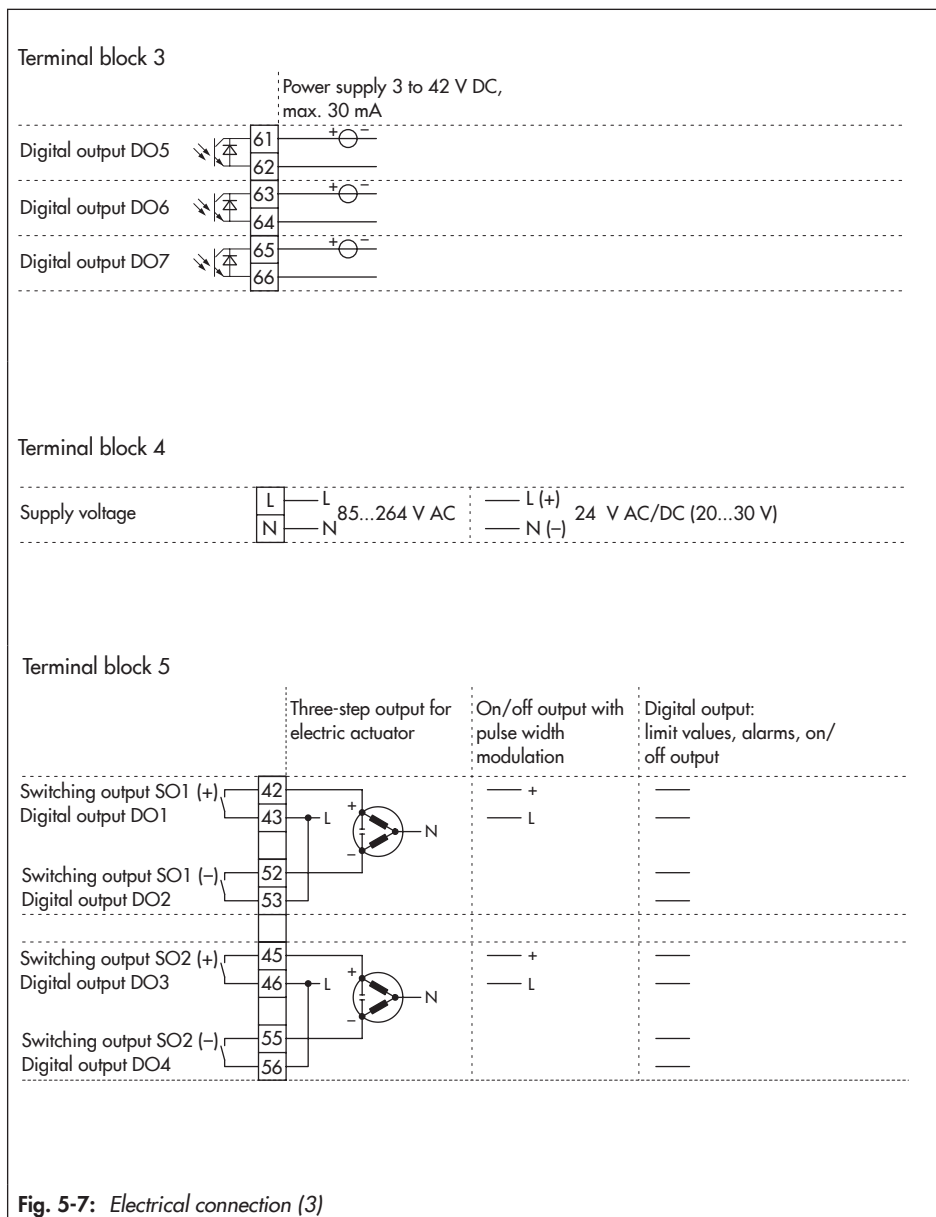
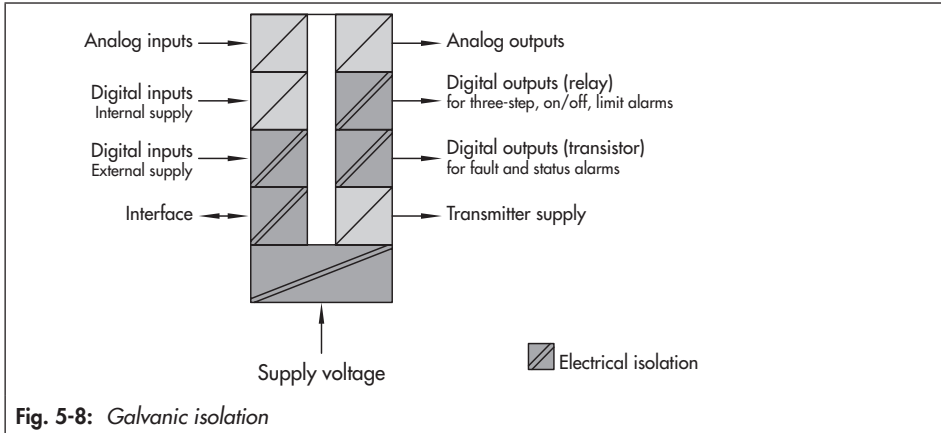

Fig. 5-7: Electrical connection (3)

Installation

Galvanic isolation



6 Operation

6.1 Device overview

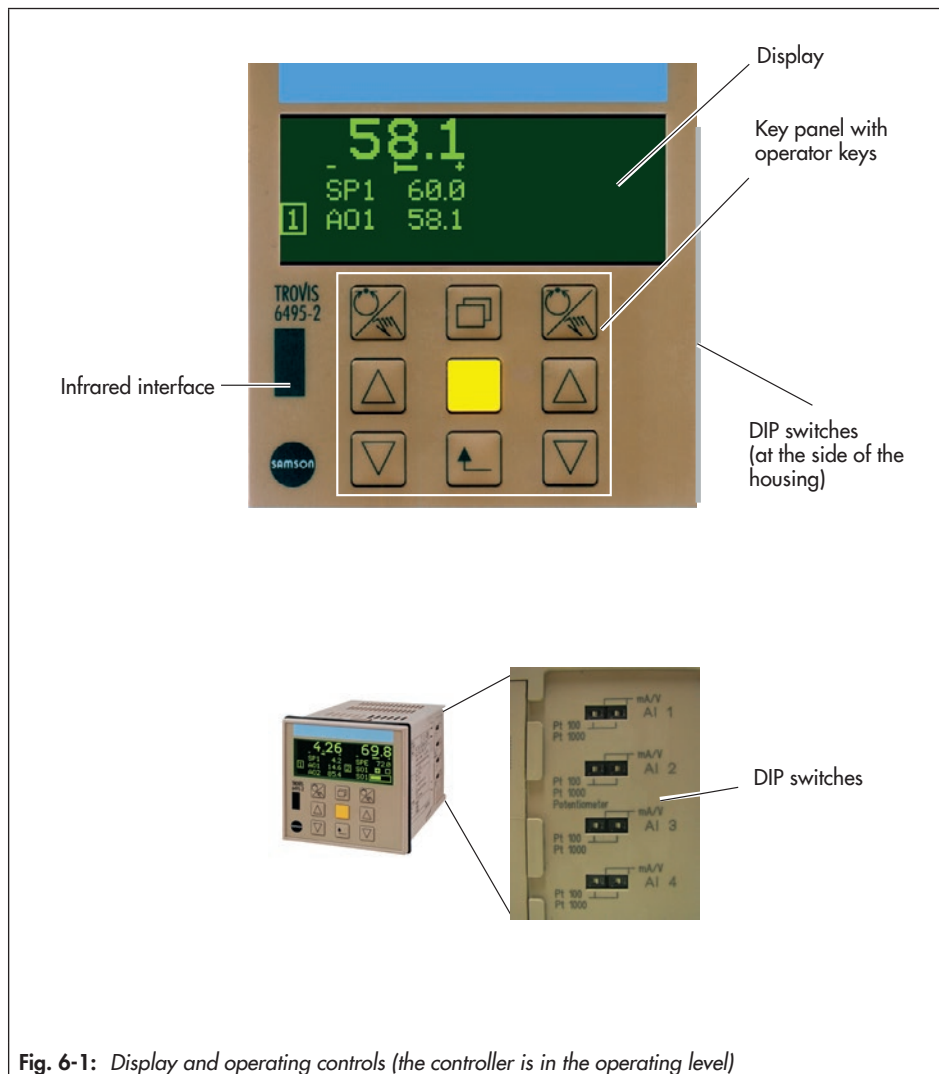

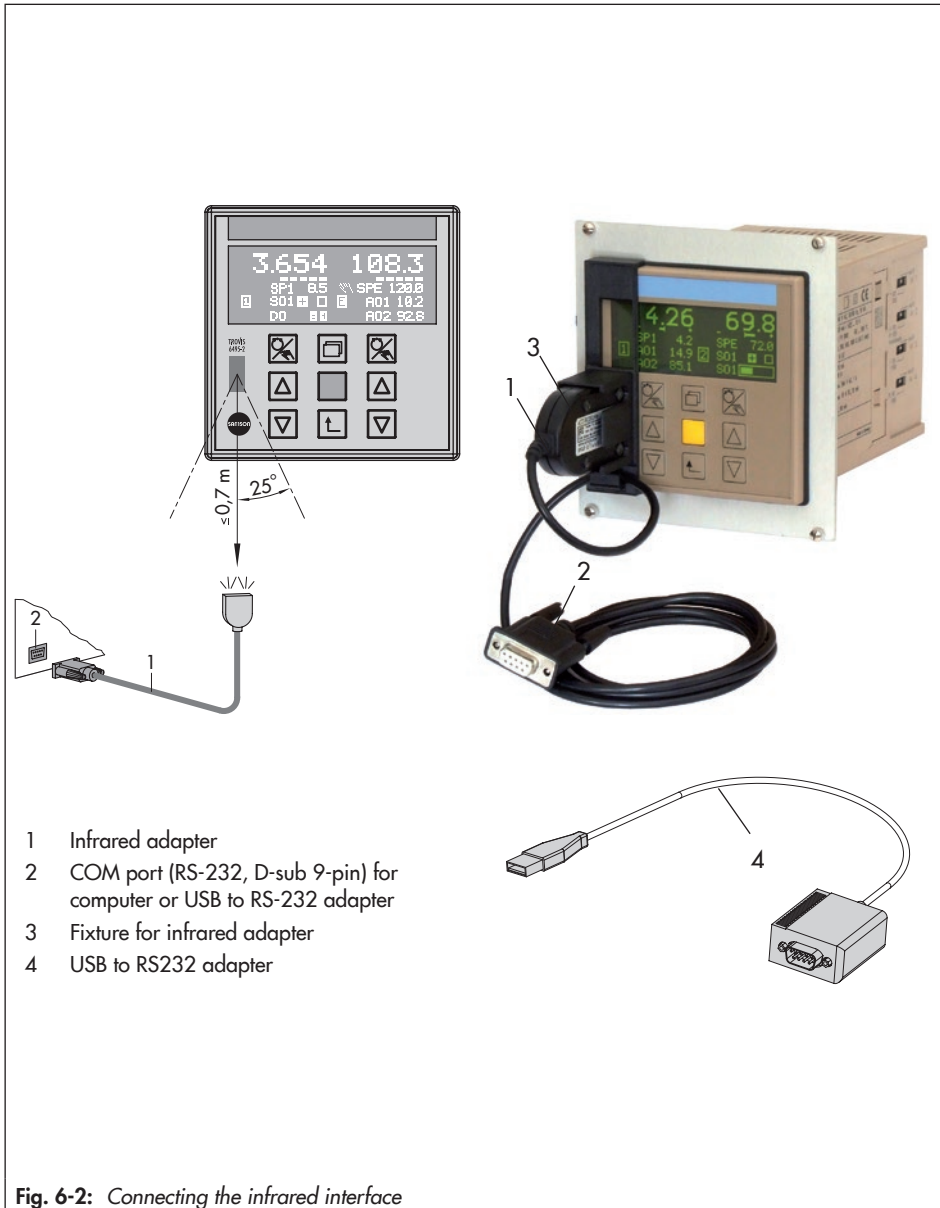

Fig. 6-2: Connecting the infrared interface

6.2 Operating controls

Display

While in operation, the controller is in the operating level.

The display is divided into two sections. Each section is assigned to one controller.

The default assignment is as follows:

- Left display: Controller [1]
- Right display: Controller [2]

The controlled variable (actual value), error signal, set point and manipulated variable (output) are displayed for each controller in the default setting.

Depending on the configuration, status alarms of the digital inputs and outputs can be shown. For control modes with just one controller, further signals can be displayed in five rows in the additional display.

Infrared interface







The infrared interface is used to exchange data between the controller and the TRO-VIS-VIEW software (see the 'Operation' section).

DIP switches

→ See Fig. 6-1.

The DIP switches are used to initially select whether an input is to accept a current/voltage signal (mA, V) or a resistance signal (Pt 100, Pt 1000, potentiometer). The DIP switches are located at the side of the housing.

Key panel with operator keys

- Left and right row:
 -  Manual/automatic key
 -  Cursor key (up)
 -  Cursor key (down)
- Middle row:
 -  Info key
 -  Enter key
 -  Escape key

i Note

A difference is only made between the keys on the left and right in the operating level. In this case, the keys on the left are used to operate the controller on the left display and the keys on the right are used to operate the controller on the right display.

The function of the keys varies depending on the level/menu which is active (see Table 6-1).

6.3 Operating structure

The controller has the following levels:

Operating level

→ See Fig. 6-1.

The controller is in this level while in operation. Key information on the control process is displayed in this level.

Info menu

→ See the 'Operation' section.

Information on the running process and firmware version can be viewed in the info menu.

Operating menu

→ See the 'Operation' section.

Settings can be made to the control parameters and set point under two menu items in the operating menu.





Configuration menu

→ See the 'Start-up and configuration' section.

In the configuration menu, the controller is adapted to its control task by changing individual configuration items and parameters.

The configuration menu is subdivided into various menus and submenus. The submenus contain the individual configuration items and parameters.

Table 6-1: Overview: Function of keys depending on the level

Operator key	Operating level	Info menu	Operating menu	Configuration menu
 Manual/ automatic key	<ul style="list-style-type: none"> – Switch between manual and automatic control mode – Cascade control: Open/close controller cascade 	<ul style="list-style-type: none"> – No function 	<ul style="list-style-type: none"> – No function 	<ul style="list-style-type: none"> – Edit individual items of parameters
 Cursor keys	<ul style="list-style-type: none"> – Automatic mode: Change set point – Manual mode: Change output value 	<ul style="list-style-type: none"> – Browse through menu and information 	<ul style="list-style-type: none"> – Browse through menu – Change set point and control parameters 	<ul style="list-style-type: none"> – Browse through menus, submenus, configuration items and parameters – Set configuration items and parameters
 Enter key	<ul style="list-style-type: none"> – Enter main menu (operating menu and configuration menu) 	<ul style="list-style-type: none"> – Activate menu items 	<ul style="list-style-type: none"> – Confirm settings – Switch set point 	<ul style="list-style-type: none"> – Enter menus, submenus, configuration items and parameters – Confirm settings
 Info key	<ul style="list-style-type: none"> – Enter info menu 	<ul style="list-style-type: none"> – No function 	<ul style="list-style-type: none"> – No function 	<ul style="list-style-type: none"> – No function
 Escape key	<ul style="list-style-type: none"> – Confirm restart after supply voltage failure 	<ul style="list-style-type: none"> – Return to the operating level stepwise 	<ul style="list-style-type: none"> – Return to the operating level stepwise 	<ul style="list-style-type: none"> – Return to the operating level stepwise

7 Start-up and configuration

The work described in this section is only to be performed by personnel appropriately qualified to carry out such tasks.

Before start-up, make sure the following conditions are met:

- The industrial controller is properly mounted according to the instructions.
- The electrical connection is properly performed.

After applying the supply voltage, the industrial controller is ready for use.

→ A calibration of the analog inputs and outputs can compensate for long lines, small wire cross-sections or tolerances of measuring transducers and final control elements (see the 'Operation' section).

7.1 Configuration

The controller is configured in the configuration menu. In the configuration menu, the controller is adapted to its control task by changing individual configuration items and parameters.

The configuration menu is subdivided into various menus and submenus. The submenus contain the individual configuration items and parameters. Annex A contains an overview of all possible settings that can be made. The Configuration Manual ► KH 6495-2 contains detailed descriptions on individual configuration items as well as other helpful information.



Tip

Settings at the controller can also be performed on a computer using the TROVIS-VIEW software:

Each menu of the configuration menu has its own folder in TROVIS-VIEW, which contain further folders with submenus. In these folders, configuration items and parameters are listed.

The controller must be connected to the software for configuration with TROVIS-VIEW (see the 'Operation' section). Refer to ► EB 6661 for instructions on how to operate TROVIS-VIEW.

At the controller, use the cursor keys (▲, ▼) to browse through the configuration menu. Press the enter key (■) to select a menu item. Press the escape key (⏏) to return.

Note

Both the keys on the left and right in the key panel can be used for the configuration menu.

We recommend to follow the following configuration sequence to configure the controller:

1. Set the control mode, e.g. M.1-1.
2. Set the input, e.g. I.1.1-6.
3. Assign input to controlled variable, e.g. C.1.1.1-1.
4. Change the set point, e.g. C.2.1.1.

Start-up and configuration

- Determine the control algorithm, e.g. C.3.1.1.1.
- Assign the output, e.g. O.1.1-1.
- Set the output signal, e.g. O.1.2-1.
- Set the operating direction, e.g. O.1.3-1.
- Set the restart condition, e.g. C.4.1-0.

Two DIP switches are assigned to each analog input AI1 to AI4.

- Both DIP switches on the right: Current signal (mA or V)
- Both DIP switches on the left: Resistance signal (Pt 100 or Pt 1000) or potentiometer (only with analog input AI2)

DIP switches

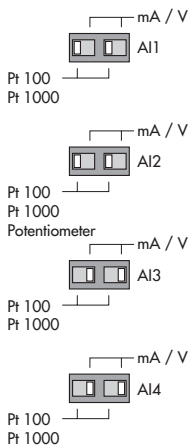

Before an analog input can be configured, the DIP switches must be set correspondingly. These switches are used to initially select whether an input is to accept a current/voltage signal (mA, V) or a resistance signal (Pt 100, Pt 1000, potentiometer). To make the initial setting effective, both DIP switches of an analog input must have the same position. If just one DIP switch is switched, an error message is generated and the digital output for error messages DO7 is activated. The fault alarm icon  is displayed in the operating level (see the 'Malfunctions' section).

Digital inputs

The following functions that have been defined over the C Controller, O Output and A General settings menus can be assigned to a digital input.

Function	Menu item
Invert digital input	I.1.5...I.1.8
Switchover between internal set points	C.2.2.1
Switchover to external set point	C.2.2.2
Opening/closing cascade	C.2.2.3
Incremental/decremental set point change	C.2.2.5
Set point increase/decrease by constant	C.2.2.6
Start set point ramp	C.2.3.1
Hold set point ramp	C.2.3.2
Invert error signal	C.3.1.3
Control mode selection P(D)/PI(D)	C.3.1.5
Activate operating point for P/PD controller	C.3.1.9 and C.3.1.10
Manual/automatic switchover	C.3.3.1
Hold output	C.3.3.2
Activate output tracking	C.3.3.3
Increase/decrease actual value	C.3.3.6
Activate constant output value	O.1.6...O.3.6, O.1.7...O.3.7, O.4.6...O.5.6 and O.4.7...O.5.7
Start output ramp	O.1.4...O.3.4 and O.4.4...O.5.4
Limit output rate	O.1.5...O.3.5
Lock control keys	A.3.1

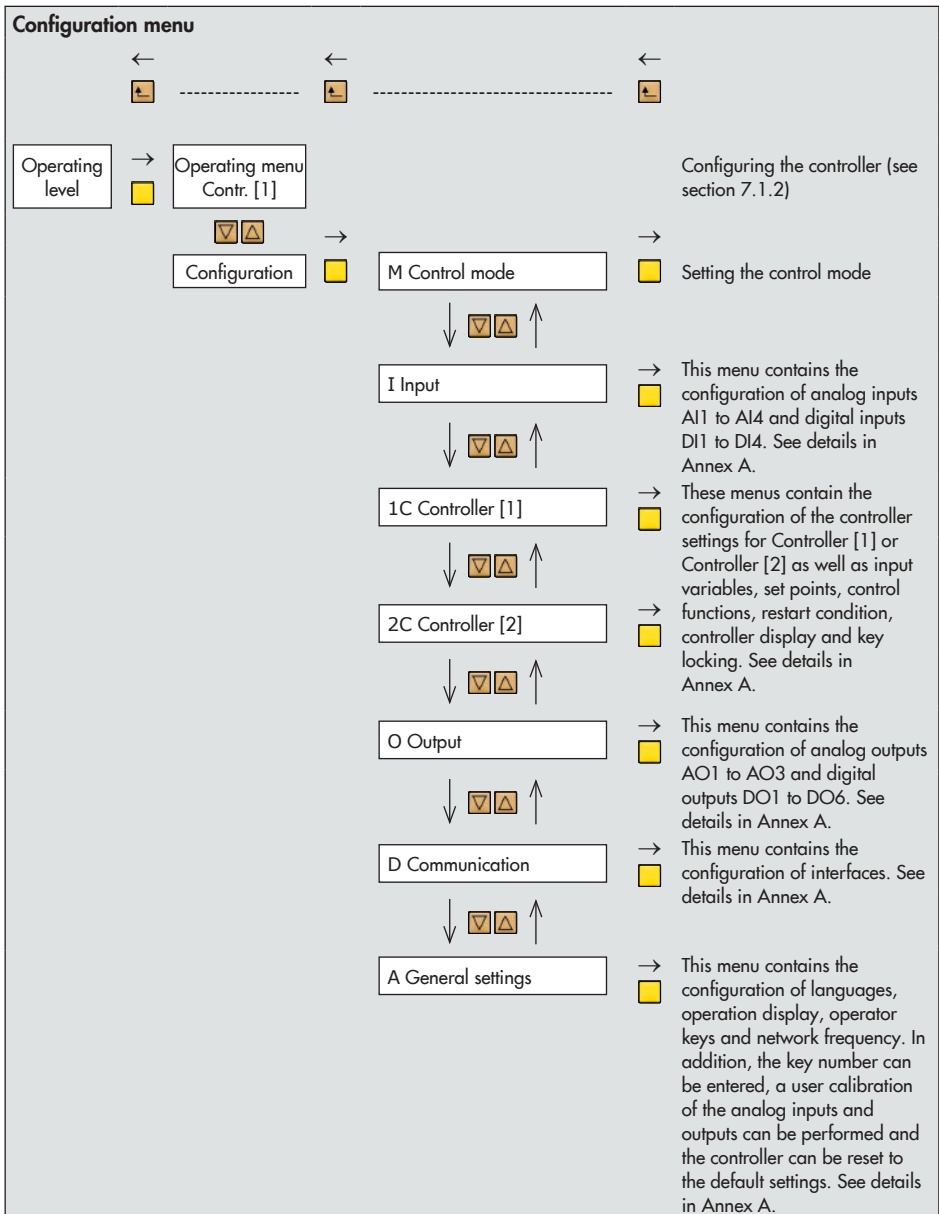

7.1.1 Entering the configuration menu

The controller is currently in the operating level:

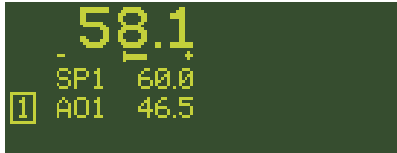

Entering the configuration menu

1x Go to the main menu.

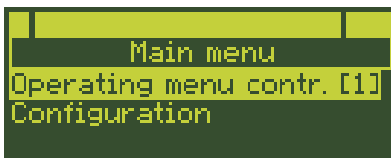

Operating menu Contr. [1] is highlighted.

1x Select Configuration menu.

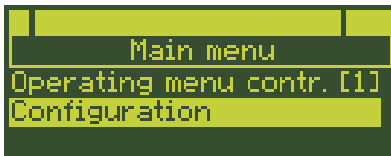

1x Enter Configuration menu.

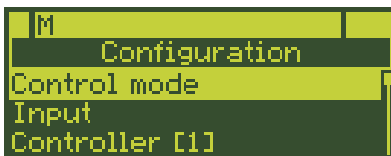

M Control mode is highlighted.

7.1.2 Configuring the controller

The controller is configured by setting the configuration items and associated parameters. Each configuration item has its own code, which gives information on its position in the configuration menu.

Example: The Input signal configuration item has the code I.1.1.

- I → I Input menu

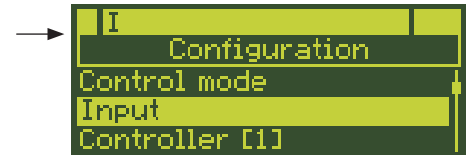

- I.1 → 1 Analog input AI1 submenu

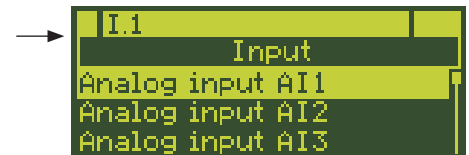

- I.1.1 → 1 Input signal configuration item with setting I.1.1 -6 Pt 100

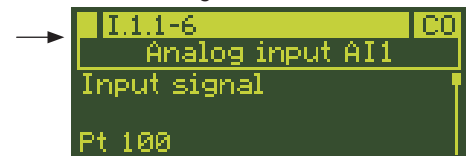

For control modes with two controllers, the controller number "1C..." (Controller [1]) and "2C..." (Controller [2]) is added to distinguish between the controllers, e.g. for C.1.1.1 Input variable PV configuration item:

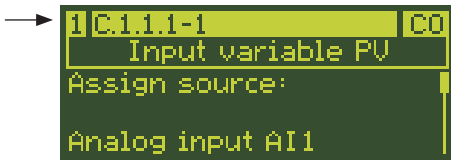

i Note

Some configuration items as well as the parameters can only be set if certain settings have already been made in the controller configuration. The required settings for the controller configuration are described in the configuration list (Annex A) and in the Configuration Manual ► KH 6495-2.

7.1.1.1 Setting configuration items

1. Read the code of the configuration item that you want to change from the configuration list (see Annex A).
2. Find the position in the configuration menu. See the example in section 7.1.2.1.

Setting configuration items

... If the configuration item that you want to set is not in the M Control mode menu, select the menu required:

- I Input
- C Controller [1]/[2]
- O Output
- D Communication
- A General settings

1x Enter menu.

The first submenu is highlighted.

... If the configuration item that you want to set is not in the highlighted submenu, select the required submenu.

1x Enter the submenu.

The first configuration item of the submenu is displayed together with its current setting.

i Note

The C Controller menu partly consists of two submenu levels. To view the individual configuration items, the submenus must be activated one after the other.

... If you want to set another configuration item or parameter other than the one displayed, select the required configuration item or parameter.

1x Activate configuration item or parameter.

Set configuration item or parameter.

1x Confirm setting.

Return to the operating level

... Return to the operating level stepwise.



7.1.2.1 Configuration example

Based on a default setting (1x Fixed set point/follow-up control M.1-1), the analog input AI1 is to be set to Pt 1000. The measuring range is to be 0 to 200 °C.

The following requirements are met:

- The code of the configuration item to determine the input signal is I.1.1, see configuration list (see Annex A).
- Lower and upper range values are set in the AI1.MIN and AI1.MAX parameters. Both parameters are assigned to the I.1.1 configuration item.
- The following position in the configuration menu can be found using the code of the configuration item:
 - I → Menu I Input
 - I.1 → 1 Analog input AI1 submenu
 - I.1.1 → 1 Input signal configuration item

Note

The analog input AI1 can only be configured as a Pt 1000 input when the DIP switches are positioned for "Pt 100/Pt 1000". Both DIP switches AI1 (at the side of the controller housing) must set to the position "Pt 100/Pt 1000" (see the 'Operation' section).

The controller is currently in the operating level:

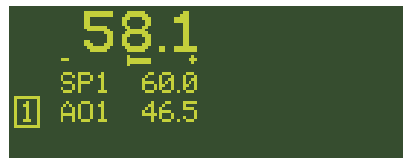

➔ Enter the configuration menu (see section 7.1.1).

Configure the input signal

 1x Select I Input menu.

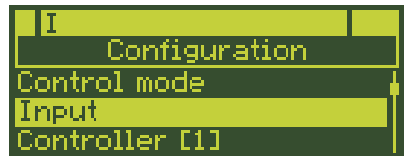

 1x Enter I Input menu.

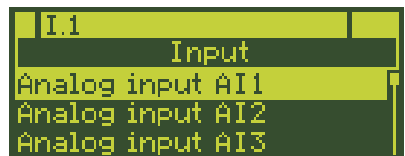

The I.1 Analog input AI1 submenu is highlighted.

Start-up and configuration

- 1x Enter I.1.1 Analog input AI1 sub-menu.

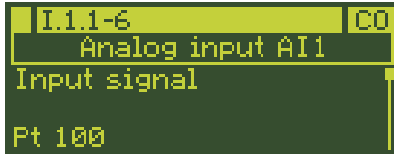

The I.1.1 Input signal configuration item is displayed together with its current setting: I.1.1-6 = Pt 100.

- 1x Activate the I.1.1 Input signal configuration item.

The input signal setting is highlighted: Pt 100

- 1x Change setting to I.1.1-7 (Pt 1000).



- 1x Confirm setting.

Adjusting the measuring range

- 1x Select AI1.MIN Lower range value parameter.

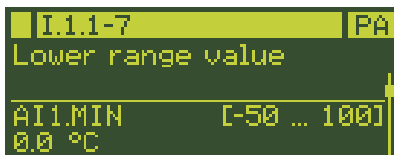

The lower range value is already set to 0 °C and does not need to be changed.

- 1x Select AI1.MAX Upper range value parameter.

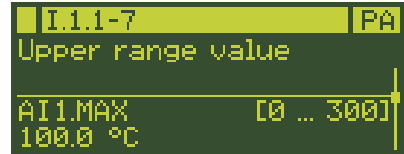

- 1x Activate AI1.MAX Upper range value parameter.
The upper range value setting is highlighted: 100.0 °C

- ... Keep pressed and change the upper range value to 200 °C.

- 1x Confirm setting.

Return to the operating level

- 4x Return to the operating level.

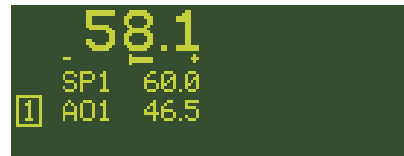

7.1.3 Adapting the display direction

The display can be adapted in the following ways:

- Changing the controller display
→ See section 7.1.3.1.
- Set up additional display
→ See section 7.1.3.2.

- Switching Controller [1] and Controller [2] displays
 - See section 7.1.3.3.

7.1.3.1 Changing the controller display

The controller display is adapted in the C.5 Controller display submenu of the corresponding Controller [1] or [2] (1C.5 or 2C.5).

Signals can be selected for each row which are to be displayed in the operating level. The type of representation (numerical, bar graph etc.) can additionally be determined for the rows 4 and 5.

The following table shows the settings necessary for adapting the display (see Annex A for details).

	Select signal	Select type of representation
Row 1	C.5.1-1...4	-
Row 2	C.5.2-1...2	-
Row 3	C.5.3-1...3	-
Row 4	C.5.4-1...41	C.5.5-1...6
Row 5	C.5.6-1...41	C.5.7-1...6

Example: Based on the default setting (1x fixed set point/follow-up controller M.1-1) the output AO1 for Controller [1] in row 5 is to be displayed as a bar graph.

According to the table above, the setting is made in 1C Controller [1] menu in the 1C.5.6 Row 5 and 1C.5.7 Row 5 representation configuration items.

The controller is currently in the operating level:

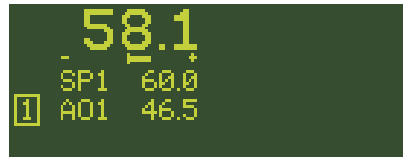

- Enter the configuration menu (see section 7.1.1).

Configure row 5

- ▣2x Select 1C Controller [1] menu.

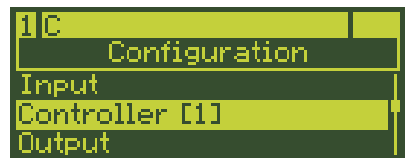

- ▣1x Activate 1C Controller [1] menu.

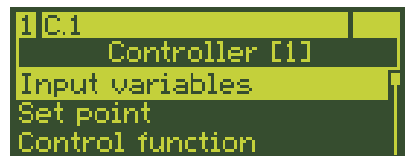

The 1C.1 Input variables submenu is highlighted.

- ▣4x Select 1C.5 Controller display submenu.

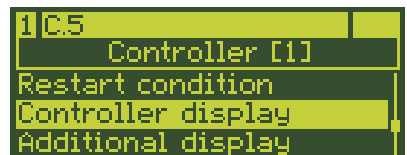

- ▣1x Enter 1C.5 Controller display submenu.

Start-up and configuration

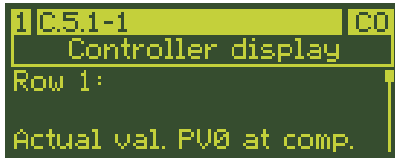

The 1C.5.1 Row 1 configuration item is displayed together with the current setting: 1C.5.1-1 = Actual value PV0 at comparator

- 5x Select 1C.5.6 Row 5 configuration item.

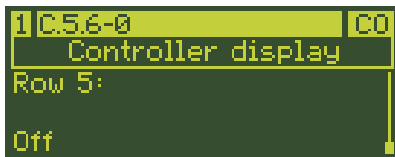

The currently active setting is displayed: 1C.5.6-0 = Off

- 1x Activate 1C.5.6 configuration item. The currently active setting is highlighted: Off.
- 2x Change setting to 1C.5.6-2 (Output AO1).

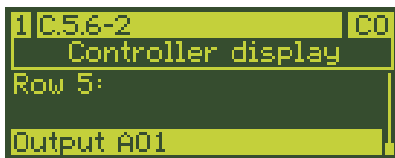

- 1x Confirm setting.

Configure row representation

- 1x Select 1C.5.7 Row 5 representation configuration item.

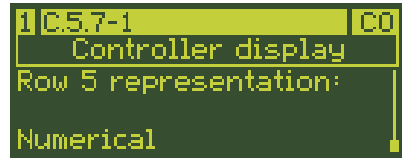

The currently active setting is displayed: 1C.5.7-1 = Numerical

- 1x Activate 1C.5.7 configuration item. The currently active setting is highlighted: Numerical.
- 2x Change setting to 1C.5.7-3 (Bar graph).

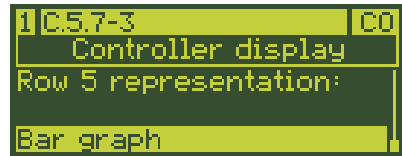

- 1x Confirm setting.

Return to the operating level

- 4x Return to the operating level.



The Output AO1 is displayed in row 5 as a bar graph.

7.1.3.2 Setting up additional display

If rows 1 to 5 in the display are all assigned and further variables are to be displayed, an additional display can be added. The additional display is activated in the A.2 Operation display submenu. Five additional rows are available. The additional display is set in the C.6 Additional display submenu of the corresponding Controller [1] or [2] (1C.6 or 2C.6).

i Note

For control modes with two controllers (M.1-3/-4/-5/-6) either one controller with additional display or both controllers without additional display can be configured. If the additional display of Controller [1], for example, covers the display of Controller [2], the display of Controller [2] can be briefly viewed by pressing one of the cursor keys (▲ or ▼) the manual/automatic key (M/A) in the operating level. It is also possible to display the additional displays of both controllers.

The following table shows the settings necessary to set up the additional display (see Annex A for details).

	Select variable	Select type of representation	Hide row
Row 1	C.6.1-1...41	C.6.2-1...6	C.6.1-0
Row 2	C.6.3-1...41	C.6.4.1...6	C.6.3-0
Row 3	C.6.5-1...41	C.6.6.1...6	C.6.5-0
Row 4	C.6.7-1...41	C.6.8-1...6	C.6.7-0
Row 5	C.6.9-1...41	C.6.10-1...6	C.6.9-0

Example: Based on the example in section 7.1.3.1, an additional display is to be set up for Controller [1] in the right display section. Its fourth row is to display the output AO2 numerically inverted..

According to the table above, the setting is made in the 1C Controller [1] menu in the 1C.6.7 Row 4 and 1C.6.8 Row 4 representation configuration items. To activate the additional display, the A.2 Operation display configuration item must be configured.

The output Y of the controller is to be assigned to the Output AO2 as a source. The controller is currently in the operating level:

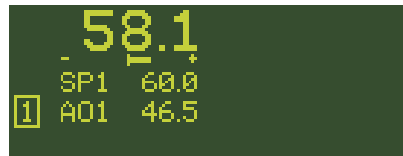

➔ Enter the configuration menu (see section 7.1.1).

Assign source for Output AO2

☑3x Select O Output menu.

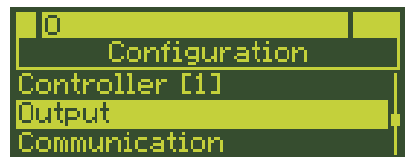

☑1x Enter O Output menu.

Start-up and configuration

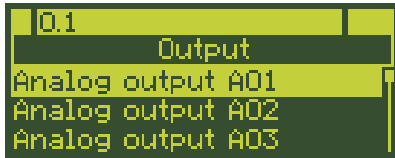

The O.1 Analog output AO1 sub-menu is highlighted.

- 1x Select O.2 Analog output AO2 sub-menu.

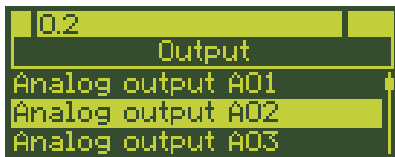

- 1x Enter O.2 Analog output AO2 sub-menu.

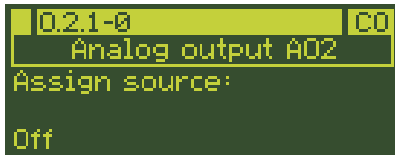

- 1x The O.2.1 Assign source configuration item is displayed together with its current setting: O.2.1-0 = Off.

- 1x Activate O.2.1 configuration item. The currently active setting is highlighted: Off.

- 1x Change setting to O.2.1-1 (Controller [1] output Y).

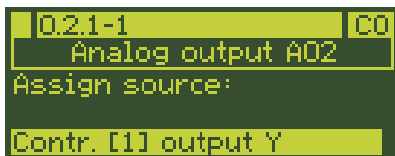

- 1x Confirm setting.

Set up additional display

- 2x Exit O Output menu.

- 1x Select 1C Controller [1] menu.

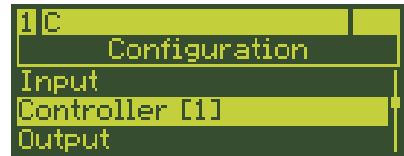

- 1x Activate 1C Controller [1] menu.

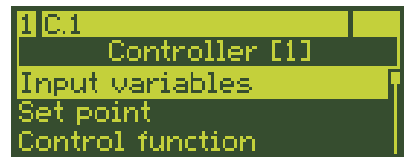

The 1C.1 Input variables sub-menu is highlighted.

- 5x Select 1C.6 Additional display menu item.

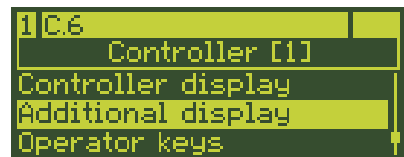

- 1x Activate 1C.6 menu item.

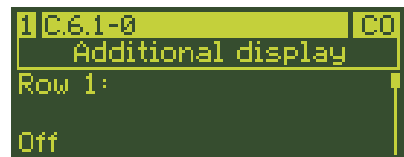

The 1C.6.1 Row 1 configuration item is displayed together with the current setting: 1C.6.1-0 = Off

- 3x Select 1C.6.7 Row 4 configuration item.

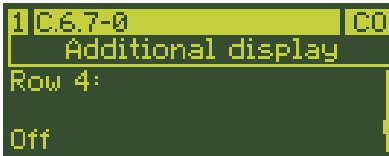

The currently active setting is displayed:
1C.6.7-0 = Off

- 1x Activate 1C.6.7 Row 4 configuration item.

The currently active setting is highlighted:
Off.

- 3x Change setting to C.6.7-3 (Output AO2).

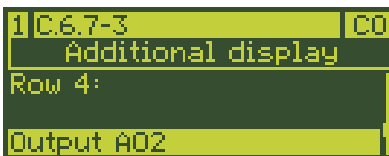

- 1x Confirm setting.

- 1x Select 1C.6.8 Row 4 representation configuration item.

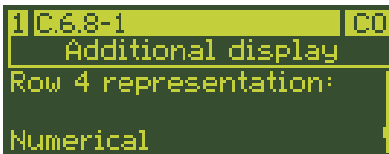

The currently active setting is displayed:
1C.5.7-1 = Numerical

- 1x Activate 1C.6.8 Row 4 representation configuration item.

The currently active setting is highlighted:
Numerical.

- 1x Change setting to 1C.6.8-2 (Numerical, inverted).

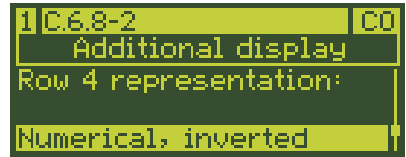

- 1x Confirm setting.

Activate additional display

- 2x Return to menu list.

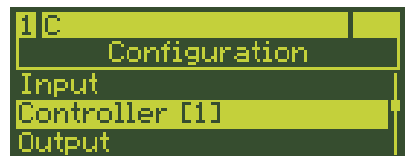

- 3x Select A General settings menu.



- 1x Enter A General settings menu.

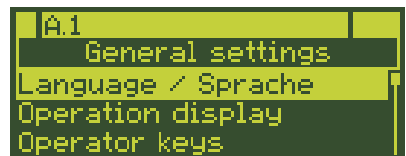

The A.1 Language / Sprache sub-menu is highlighted.

- 1x Select A.2 Operation display sub-menu.

Start-up and configuration

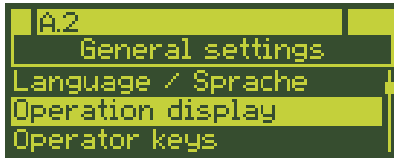

1x Confirm setting.

- 1x Enter A.2 Operation display sub-menu.

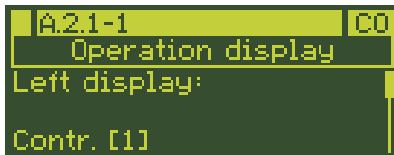

The A.2.1 Left display configuration item is displayed together with its current setting: A.2.1-1 = Controller [1]

- 1x Select A.2.2 Right display submenu.



The currently active setting is displayed: Right display = Off.

- 1x Activate A.2.2 Right display sub-menu.
The currently active setting is highlighted: Off.
- 1x Change setting to A.2.2-2 (Controller [1] additional reading).



Return to the operating level

 4x Return to the operating level.

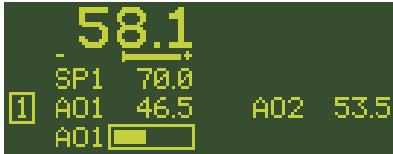

In the additional reading on the right in the display, the Output AO2 is displayed numerically inverted.

7.1.3.3 Switching Controller [1] and Controller [2] displays

The left display is assigned to Controller [1] and the right display to Controller [2] in the default setting. Controller [1] is operated on the left and Controller [2] on the right accordingly. If required, both controller displays can be switched around so that the left display is for Controller [2] and the right display is for Controller [1].

Example: For cascade control (setting M.1-3) the left display is assigned to the slave controller and the right display is assigned to the master controller. The displays are to be switched so that the master controller (Controller [2]) is shown in the left display and the slave controller (Controller [1]) is shown in the right display. To do this, the submenu settings A.2.1 Left display and A.2.2 Right display must be changed.

Note

Before Controller [1] can be assigned to the right display, it must first be removed from the left display as one controller cannot be assigned to both displays at the same time.

The controller is currently in the operating level:

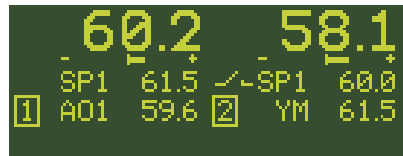

→ Enter the configuration menu (see section 7.1.1).

Deactivate left display

 6x Select A General settings menu.



 1x Enter A General settings menu.

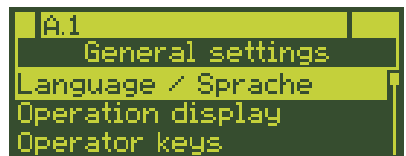

The A.1 Language / Sprache submenu is highlighted.

Start-up and configuration

- 1x Select A.2 Operation display sub-menu.

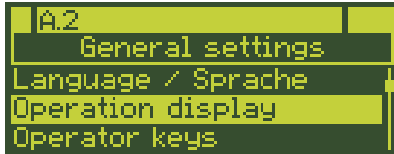

- 1x Enter A.2 Operation display sub-menu.

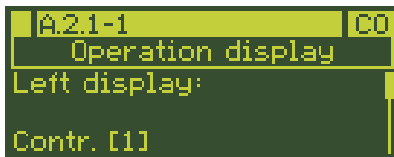

The A.2.1 Left display configuration item is displayed together with its current setting: A.2.1-1 = Controller [1].

- 1x Activate A.2.1 Left display configuration item.
The currently active setting is highlighted: Controller [1]
- 1x Setting in A.2.1-0 (Off).



- 1x Confirm setting.

Configure right display

- 1x Select A.2.2 Right display configuration item.

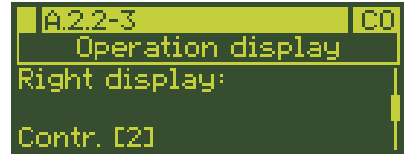

- 1x Activate A.2.2 Right display configuration item.
The currently active setting is highlighted: Controller [2]
- 2x Change setting to A.2.2-1 (Controller [1]).

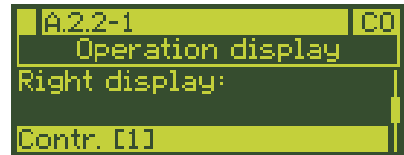

- 1x Confirm setting.

Configure left display

- 1x Select A.2.1 Left display configuration item.

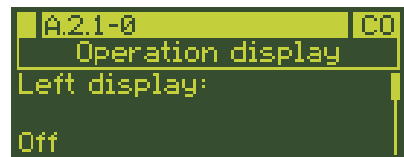

- 1x Activate A.2.1 Left display configuration item.
The currently active setting is highlighted: Off.

- ▾ 2x Change setting to A.2.1-3 (Controller [2]).

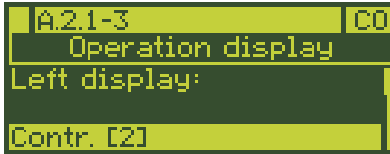

- ▢ 1x Confirm setting.

Return to the operating level

- ▢ 4x Return to the operating level.

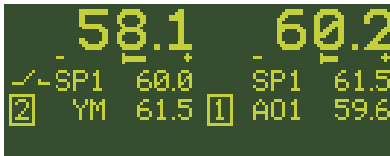

The left display is now assigned to Controller [2] and Controller [1] is assigned to the right display.

7.2 Configuration using the TROVIS-VIEW software

TROVIS-VIEW provides a uniform user interface that allows users to configure and parameterize various SAMSON devices using device-specific database modules. The TROVIS 6495-2 device module can be downloaded free of charge from our website at ► www.samsongroup.com > SERVICE & SUPPORT > Downloads > TROVIS-VIEW. Further information on TROVIS-VIEW (e.g. system requirements) is available on our website and in the Data Sheet ► T 6661.

7.3 User calibration

The analog inputs and outputs are factory-calibrated.

A system-related user calibration can compensate for long lines, small wire cross-sections or tolerances of measuring transducers and final control elements. The calibration is similar in principle to a scaling. The gradient and zero shift are automatically calculated by the controller.

i Note

The function A.21.1-2 allows the controller to be reset to factory-calibration settings.

7.3.1 Calibrating analog inputs

→ Connect signal source at the input.

Zero point

1. Activate Zero menu item depending on the analog input and signal type.
Example: A.20.1.9 for Analog input AI1 and Pt100 (see Annex A).
2. Set the signal source to the initial value.
If the input value is within the range that can be calibrated, the selection bar is displayed.
3. Press the enter key (▢) to confirm the value.

The zero point has been calibrated.

Start-up and configuration

End value

1. Activate End menu item depending on the analog input and signal type.
Example: A.20.1.10 for Analog input AI1 and Pt 100 (see Annex A).
2. Set the signal source to the end value.
If the input value is within the range that can be calibrated, the selection bar is displayed.
3. Press the enter key (□) to confirm the value.
The end value has been calibrated.

7.3.2 Calibrating analog outputs

→ Connect a precision measuring instrument at the output.

Zero point

1. Activate Zero menu item depending on the analog output and signal type.
Example: A.20.5.1 for Analog output AO1 and mA signal (see Annex A).
2. Set the output signal using the cursor keys (▲ and ▼) to the initial value.
If the output value is within the range that can be calibrated, the selection bar is displayed.
3. Press the enter key (□) to confirm the value.
The zero point has been calibrated (reading: 0.0 %).

End value

1. Activate End menu item depending on the analog output and signal type.
Example: A.20.5.2 for Analog output AO1 and mA signal (see Annex A).
2. Set the output signal using the cursor keys (▲ and ▼) to the end value.
If the output value is within the range that can be calibrated, the selection bar is displayed.
3. Press the enter key (□) to confirm the value.
The end value has been calibrated (reading: 100.0 %).

8 Operation



8.1 Operating level

While in operation, the controller is in the operating level. Key information on the control process is displayed in this level.

Default reading on display:

Row 1	Actual value PV0 at comparator
Row 2	Error signal +/-e
Row 3	Set point SP1 ... SP4, SPE, SPC
Row 4	Output according to priority
Row 5	Unassigned

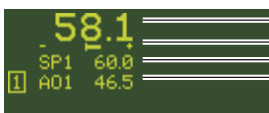
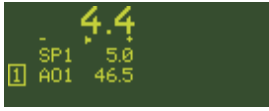
Table 8-1: Overview: Default reading on display in the operating level for various control modes

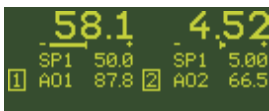
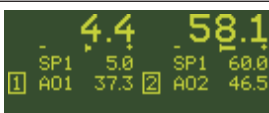
Control mode		Operating level (default reading)
M.1-1 1x Fixed set point/follow-up control	Controller [1]	 <div style="display: flex; justify-content: flex-end; margin-left: 10px;"> <div style="margin-bottom: 5px;">_____ Row 1</div> <div style="margin-bottom: 5px;">_____ Row 2</div> <div style="margin-bottom: 5px;">_____ Row 3</div> <div style="margin-bottom: 5px;">_____ Row 4</div> </div>
M.1-2 Ratio control	Controller [1]	
M.1-3 Cascade control	Slave controller [1]	 <div style="display: flex; justify-content: flex-end; margin-left: 10px;"> <div style="margin-bottom: 5px;">_____ Main controller [2]</div> </div>
M.1-4 Override control	Main controller [1]	 <div style="display: flex; justify-content: flex-end; margin-left: 10px;"> <div style="margin-bottom: 5px;">_____ Override controller [2]</div> </div>
M.1-5 2x Fixed set point/follow-up control	Controller [1]	 <div style="display: flex; justify-content: flex-end; margin-left: 10px;"> <div style="margin-bottom: 5px;">_____ Controller [2]</div> </div>
M.1-6 Ratio controller and controller	Ratio controller [1]	 <div style="display: flex; justify-content: flex-end; margin-left: 10px;"> <div style="margin-bottom: 5px;">_____ Controller [2]</div> </div>

Operation

The display in the operating level is arranged depending on the control mode selected. For control modes with two controllers, the default display has two sections: Controller [1] on the left display section and Controller [2] on the right display section (see the 'Operation' section).

i Note

The default reading can be adapted as required (see Annex A).

To operate the controller, use the cursor keys (▲, ▼) and the manual/automatic key (◻) in the operating level. These keys are located on the left and right of the key panel. In this case, the keys on the left are used to operate the controller on the left display and the keys on the right are used to operate the controller on the right display.

The following actions can be performed in the operating level:

- Adjust set point
 - ➔ See section 8.1.1.
- Switching over to manual mode and changing the output
 - ➔ See section 8.1.2.
- Open/close cascade (only with cascade control (setting M.1-3))
 - ➔ See section 8.1.3.

8.1.1 Adjusting the set point

Change the set point in automatic mode using the cursor keys:

- ▲ Increase the set point.
- ▼ Decrease the set point.

i Note

The last digit is changed by one value every time the key is pressed. Hold the key down to change the value at a faster rate.

8.1.2 Switching over to manual mode and changing the output

i Note

The left display for Controller [1] is shown in the following examples. Consequently, the keys on the left are used for operation.

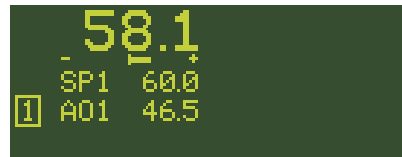

- ◻ 1x Switch to manual mode.

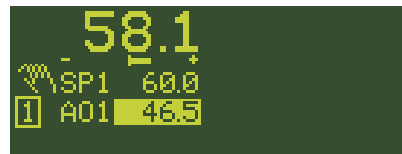

The hand icon  appears above the controller designation [1]/[2].

The currently active manipulated variable (output) is highlighted: AO1 = 46.5 %

... Increase the set point.

... Decrease the set point.

i Note

The last digit is changed by one value every time the key is pressed. Hold the key down to change the value at a faster rate.

Return to automatic mode.

1x Change to automatic mode.

The hand icon  is no longer displayed.

8.1.3 Opening/closing cascade

The opening/closing cascade function is only possible for cascade control (setting M.1-3).

The cascade is opened and closed by pressing the manual/automatic key  of the master controller [2].

i Note

In the following example, the master controller [2] is shown on the right display (default). As a result, the manual/automatic key on the right is used to open/close the cascade.

1x Close the cascade.

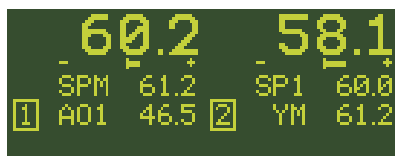



The cascade icon  is no longer displayed when the cascade is closed.

The output value YM of the master controller [2] specifies the set point SPM of the slave controller [1]: SPM = YM.

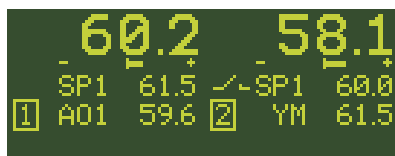
1x Open the cascade.







The cascade icon  appears when the cascade is opened.

The set point of the slave controller [1] can be changed using the cursor keys (, ).

The cascade can also be opened/closed over a digital input. See C.2.2.3 configuration item in Annex A and section C.2.2.3 in the Configuration Manual ► KH 6495-2.

8.2 Info menu

Information on the running process and the controller can be viewed in the info menu. Usually, there are the following menu items Controller [1], possibly Controller [2], Inputs/outputs, Last events, Diagnosis and Versions. If an error message exists, the Error message menu item is added to the info menu.

Enter the info menu by pressing the info key . Use the cursor keys (, ) to browse through the menu. Press the enter key  to select a menu item. Press the escape key  to return.

i Note

Both the keys on the left and right in the key panel can be used for the info menu.

Example: A control mode with one controller is configured. An error message does not exist in the controller. The objective of the example is to find out the current values of analog inputs AI1 and AI2.

The controller is currently in the operating level:

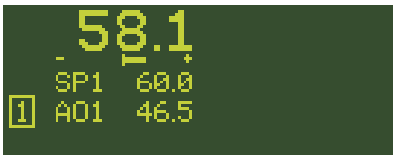

Enter info menu

 1x Change to the info menu.

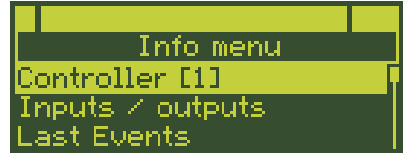

The Controller [1] menu item is highlighted on the display.

Activate analog input readings

 1x Select Inputs/outputs menu item.

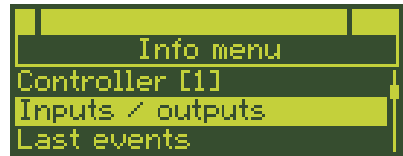

 1x Activate Inputs/outputs menu item.

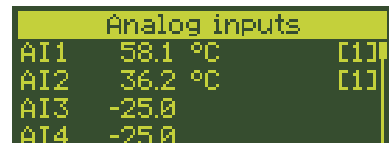

The analog inputs are displayed with their current values.

Return to the operating level

 2x Return to the operating level.

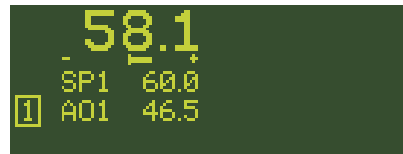

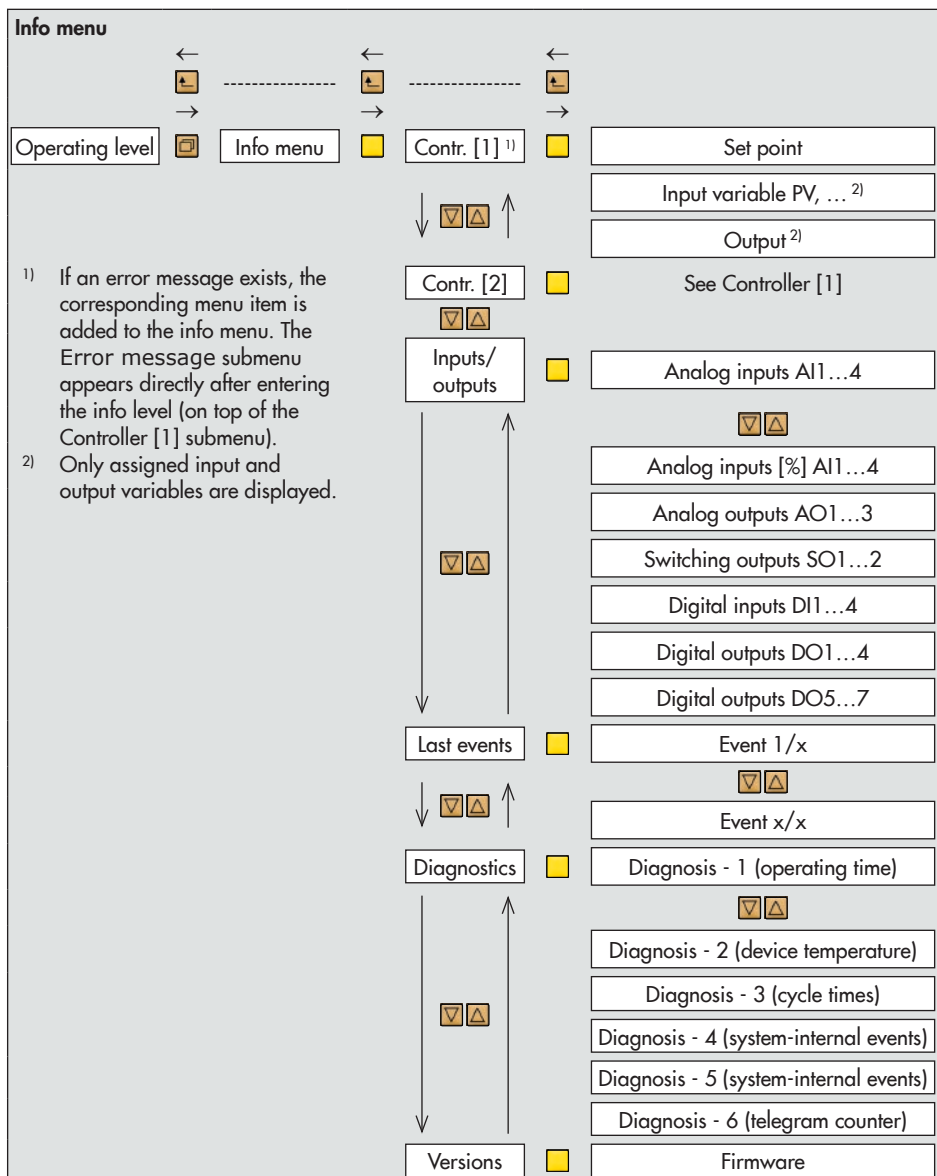

Notes concerning the readings in the info menu

– Inputs/outputs menu item

Directly after the digital inputs and outputs, the state of the input/output is indicated: (0) or (1)

In the case of a reversed digital input or output, the state of the input/output in reversed form is additionally indicated: inv.(1) or inv.(0)

Digital inputs		
DI1	(0) inv.(1)	[1;2;0]
DI2	(0)	[1;0;X]
DI3	(0)	
DI4	(0)	

The controller assigned to the input/output is indicated on the right of the display ([1] or [2]) in the reading of analog inputs, digital inputs, analog outputs, switching outputs and digital outputs. If the input/output is assigned to both controllers, both controller numbers ([1; 2]) are indicated.

Additional readings apply to the digital inputs (separate or combined with the controller number):

- [O] indicates that the digital input is assigned to an output.
- [X] indicates that the digital input activates the key locking.

Digital outputs		
DO1	(0) inv.(1)	[1]
DO2	(0)	[1;2]
DO3	(0)	[0]
DO4	(0)	[1]

Additional readings apply to the digital outputs (separate or combined with the controller number):

- [I] indicates that the digital output is activated by a digital input.
- [O] indicates that another digital output has been assigned as the source to the digital output.

– Last events menu item

Event (1/49)	
002:02:23	
Event 0003	
Warm start	

Any events that occur are logged and time-stamped. The last event is always listed first.

– Diagnosis - 1 menu item

```
Diagnose - 1
Operating time:      0.06:49:18
Total Operating time: 0.14:49:18
```

Operating time indicates the time the controller has been operating since the last start-up of the controller in days.hours:Minutes:Seconds.

The total operating time refers to how long the controller has been supplied with voltage (Days.Hours:Minutes:Seconds).

– Diagnosis - 2 menu item

```
Diagnose - 2
Device temp: 25.0 °C
```

NOTICE

Controller damage due to the violation of the permissible ambient temperature range.

→ When installing the controller, observe the permissible ambient temperature (0 to 50 °C).

The device inside temperature is monitored to protect the controller and to guarantee the measuring accuracy of the analog inputs. The measuring error at the analog inputs increases, the more the ambient temperature deviates from 20 °C (see the 'Design and principle of operation' section). If the temperature inside the controller falls below 0 °C or rises above 60 °C, a message is generated in Last events. If the temperature inside the controller falls below -5 °C or rises above +65 °C, a further message is generated in Last events and Error message and the fault alarm icon  blinks on the display. The digital output DO7 is activated.

– Diagnosis - 3 menu item

```
Diagnose - 3
Ta: 102.3 ms
Ta: 099.9 ms (min)
Ta: 102.3 ms (max)
```





Reading of current scanning time

The scanning time (min) can be reset by pressing the left manual/automatic key  and the scanning time (max) can be reset by pressing the right manual/automatic key.

8.3 Operating menu

The operating menu consists of the Control parameters and Set point menu items. The following actions can be performed:

- Changing control parameters
→ See section 8.3.2.
- Switching over internal/external set point
→ See section 8.3.3.
- Switching over and changing internal set points
→ See section 8.3.4.

Press the enter key  to enter the operating menu. Use the cursor keys (, ) to browse through the menu. Press the enter key  to select a menu item.

i Note

Both the keys on the left and right in the key panel can be used for the operating menu.

8.3.1 Entering the operating menu

The controller is currently in the operating level:

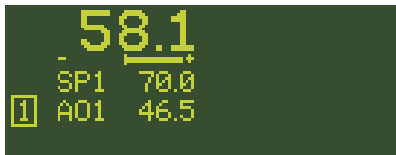

Enter Operating menu Contr. [1]

 1x Go to the main menu.

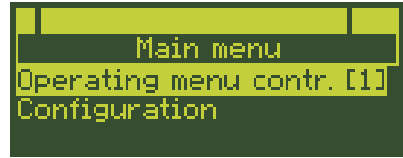

Operating menu Contr. [1] is highlighted.

 1x Enter Operating menu Contr. [1].

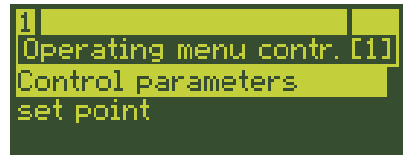

The Control parameters submenu is highlighted.

i Note

Enter the operating menu for Controller [2] in the same way after selecting it ().

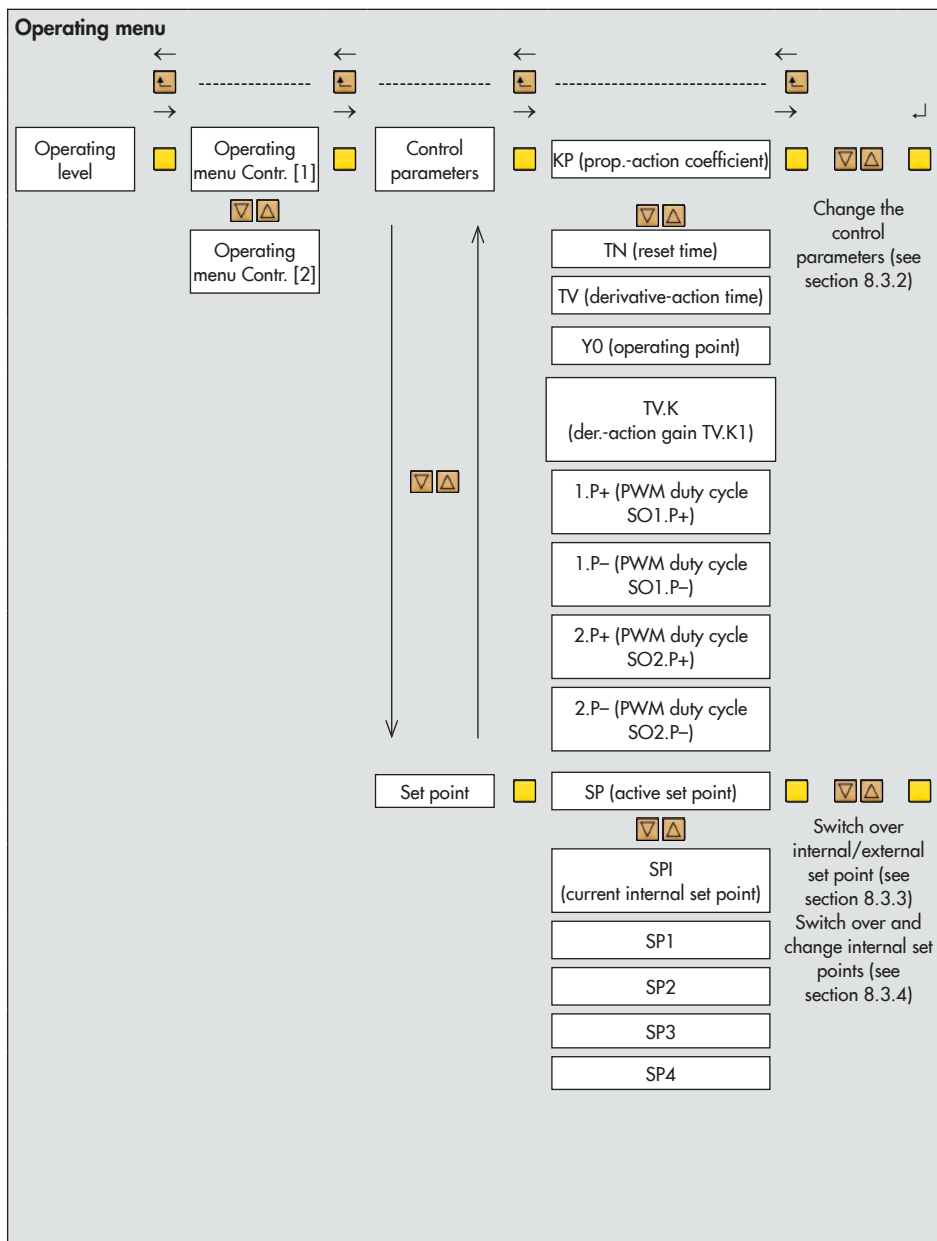

8.3.2 Changing the control parameters

After entering the operating menu (see section 8.3.1), the control parameters are changed in the Control parameters menu item. Depending on the control behavior, the proportional-action coefficient KP, reset time TN, derivative-action time TV, derivative-action gain TV.K and operating point Y0 can be changed:

Assignment between control parameters and control behavior					
C.3.1.1.1	PI -1	P -2	PD -3	PID -4	I -5
KP	•	•	•	•	•
TN	•	–	–	•	•
TV	–	–	•	•	–
Y0	•	•	•	•	•
TV.K	–	–	•	•	–

i Note

If on-off/three-step outputs are configured with pulse width modulation (PWM), the corresponding duty cycles (SO1.P+, SO1.P-, SO2.P+, SO2.P-) can be changed.

Example: The reset time TN for Controller [1] is to be changed to 100 s.

➔ Enter the operating menu (see section 8.3.1).

Change the reset time TN

1x Activate Control parameters menu item.

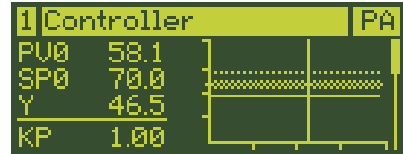

The actual value at the comparator PV0 (■), the set point at the comparator SP0 (■) and the manipulated variable Y (■) are indicated on the left (for ratio control: Actual ratio PVR, ratio set point SPR and manipulated variable Y).

Their course within the last minute in the 0 to 100 % range of the measuring range is plotted on the right.

The current value of the proportional-action coefficient KP is indicated below.

1x Select reset time TN.

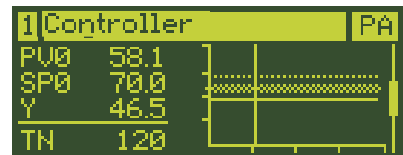

1x Activate reset time TN.

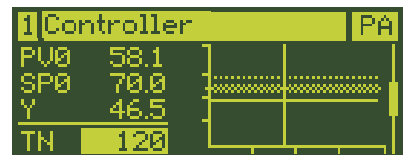

The current value of the reset time is highlighted: 120 s.

- ▣... Keep pressed and change the reset time TN to 100 s.

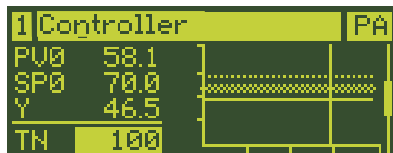

- ▣1x Confirm the reset time.

Return to the operating level

- ▣3x Return to the operating level.



8.3.3 Switching over internal/external set point

If the external set point SPE (C.2.1.2-1) is configured, the set point SP is equal to SPE. The switchover to an internal set point SPI is performed in the operating menu.

The controller is currently in the operating level:

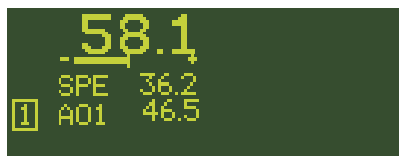

- ➔ Enter the operating menu (see section 8.3.1).

Switchover to the internal set point SPI

- ▣1x Select Set point menu item.

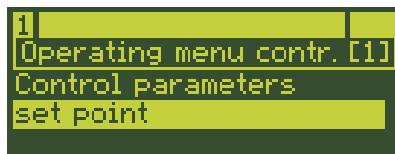

- ▣1x Activate Set point menu item.

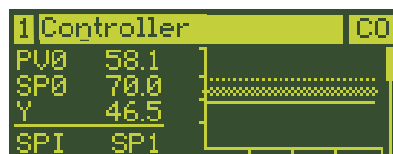

The current set point is displayed: SP = SPE.

- ▣1x Activate the set point SP.

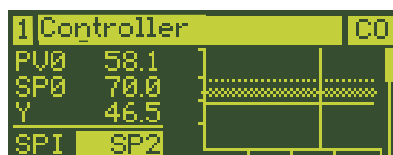

The current set point is highlighted: SPE.

- ▣1x Select internal set point SPI.

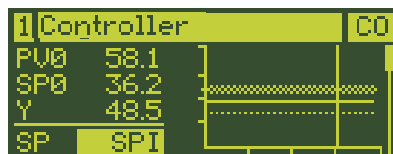

- ▣1x Confirm setting.
SPI is now the active set point.

Operation

i Note

Determining and changing the internal set point is described in section 8.3.4.

Cascade control

For cascade control (M.1-3) the cascade can also be opened and closed by switching over the set point.

- The cascade is opened if the following applies in the slave controller [2]: SP = SPI.
- The cascade is closed if the following applies in the slave controller [2]: SP = SPM.

8.3.4 Switching over and changing internal set points

In the operating menu, one of the set points SP1, SP2, SP3 or SP4 can be assigned to the internal set points SPI, depending on the configuration.

Required configuration for determining the set point	
SP1	C.2.1.1-1/-2/-3/-4
SP2	C.2.1.1-2/-3/-4
SP3	C.2.1.1-3/-4
SP4	C.2.1.1-4

Example: The controller [1] has two internal set points SP1 and SP2 (configured with 1C.2.1.1-2).

- The set point SP1 is to be switched over to set point SP2.
- The set point SP1 is to be kept at 70 while the set point SP2 is to be changed to 100.

The controller is currently in the operating level:



- Enter the operating menu (see section 8.3.1).

Switchover between internal set points

- 1x Select Set point menu item.

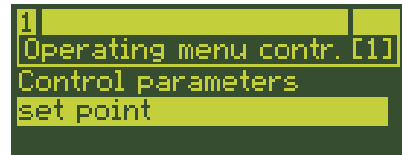

- 1x Activate Set point menu item.

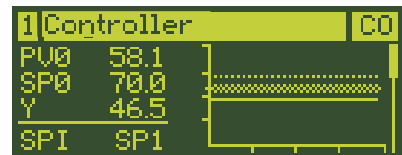

The actual value at the comparator PVO (■), the set point at the comparator SP0 (■) and the manipulated variable Y (■) are indicated on the left (for ratio control: Actual ratio PVR, ratio set point SPR and manipulated variable Y).

Their course within the last minute in the 0 to 100 % range of the measuring range is plotted on the right.

The assignment of the internal set point (in this case: SPI = SP1) is indicated below.

- 1x Activate the internal set point. The current internal set point is highlighted: SP1.

- 1x Set the internal set point SPI = SP2.

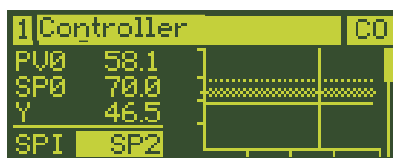

- 1x Confirm setting. SP2 is now the active set point.

Change set points SP1 and SP2

- 1x Select the set point SP1.

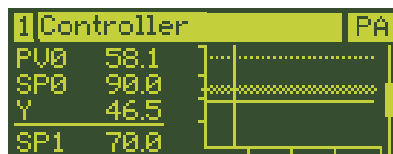

The set point SP1 has the required value of 70.0 and therefore does not need to be changed.

- 1x Select the set point SP2.

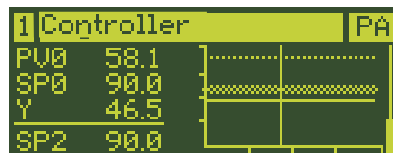

- 1x Activate the set point setting SP2. The current set point is highlighted: 90.0.

- △... Keep pressed and change the set point to 100.0.

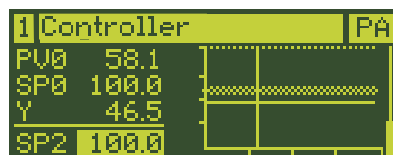

- 1x Confirm the set point. The set point is adopted.

Return to the operating level

- 3x Return to the operating level.

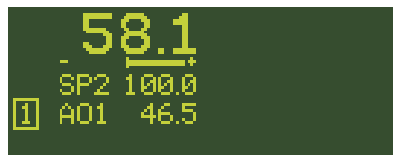

i Note

In firmware version 1.21 and higher, switchover to internal set points released with C.2.1.1 can be performed over Modbus

Operation

with holding register 55 (Controller [1]) and 115 (Controller [2]) ► KH 6495-2.

- Value 1 = Set point SP1 active
- Value 2 = Set point SP2 active
- Value 3 = Set point SP3 active
- Value 4 = Set point SP4 active

The switchover over Modbus has the same priority as switchover using the keys.

The set point switchover cannot be performed either using the keys or over Modbus if the set point switchover over the digital inputs is configured.

8.4 Locking the controller

The controller can be protected against unauthorized access. There are three ways to implement the locking of the controller:

- Locking the operating level
 - ➔ See section 8.4.1.
- Locking all keys over a digital input
 - ➔ See section 8.4.2.
- Activating key number operation
 - ➔ See section 8.4.3.

8.4.1 Locking the operating level

Switchover between manual and automatic mode as well as changes to the set point for both Controller [1] and Controller [2] can be locked independently from one another.

Locking is performed in the C.7 Operator keys submenu of either Controller [1] or [2] by setting the configuration items C.7.2-1 Lock manual/auto key = On and/or C.7.3-1 Lock set point keys = On.

Example: The set point adjustment of Controller [1] is to be locked.

The controller is currently in the operating level.

- ➔ Enter the configuration menu (see the 'Start-up and configuration' section).

Activate locking

- ▼2x Select 1C Controller [1] menu.

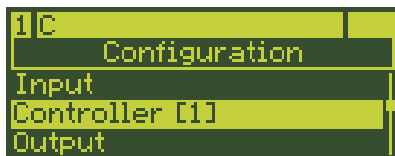

- 1x Activate 1C Controller [1] menu. The 1C.1 Input variables submenu is highlighted.

- ▼6x Select 1C.7 Operator keys submenu.

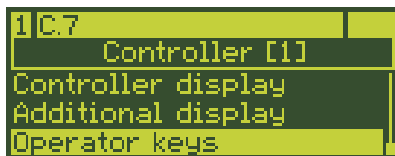

- 1x Enter 1C.7 Operator keys submenu. The 1C.7.1 Invert manual output value configuration item is displayed together with its currently active setting.

- ▼2x Select 1C.7.3 Lock set point keys configuration item.

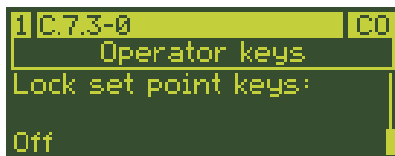

- 1x Activate 1C.7.3 Lock set point keys configuration item. The currently active setting is highlighted: Off.

- ▼1x Change setting to 1C.7.3-1 (On).

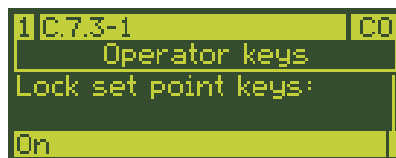

- 1x Confirm setting.

- ▲4x Return to the operating level.

Set point adjustment is locked in automatic mode in the operating level.

i Note

The operating menu Controller [1] is not affected by the locking function. The set point can still be changed (see section 8.3.4).

8.4.2 Locking all keys over a digital input

The operator keys are locked when the selected digital input is active.

The key locking is set in A General settings menu in A.3.1 configuration item.

Example: The operator keys are to be locked by the active digital input DI2.

The controller is currently in the operating level.

➔ Enter the configuration menu (see the 'Start-up and configuration' section).

Activate locking

- ▼6x Select A General settings menu.

Operation



- 1x Enter A General settings menu.



The A.1 Language / Sprache submenu is highlighted.

- 2x Select A.3 Operator keys submenu.

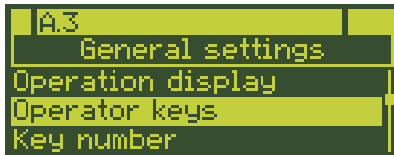

- 1x Enter A.3 Operator keys submenu.

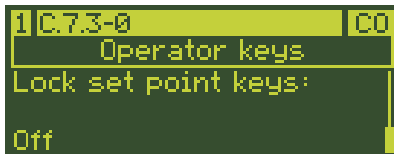

The A.3.1 Lock all keys configuration item is displayed together with the current setting: Off

- 1x Activate A.3.1 Lock all keys configuration item.

The currently active setting is highlighted: Off.

- 2x Change setting to A.3.1-2 (With digital input DI2).

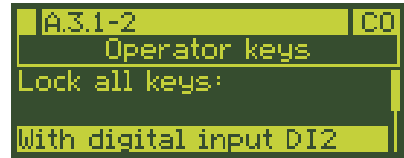

- 1x Confirm setting.

- 4x Return to the operating level.

The operator keys are locked when the digital input DI2 is active. Settings cannot be changed.

8.4.3 Activating key number operation

When key number operation is activated, control parameter settings in the operating menu as well as settings in the configuration menu can only be changed after entering a key number. The activation of the key number operation remains effective until the configuration menu is left.

i Note

The key number can be entered in the range between 0 and 9999.

💡 Tip

We recommend noting down the key number as it is needed to deactivate the key number operation as well.

Key number operation is activated in the configuration menu in A.4.1 configuration item:

The controller is currently in the operating level.

- ➔ Enter the configuration menu (see the 'Start-up and configuration' section).

Activating key number operation

- ▼5x (control modes with one controller)
- ▼6x (control modes with two controllers)

Select A General settings menu.

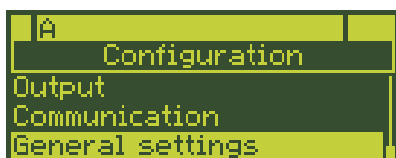

- 1x Enter A General settings menu.

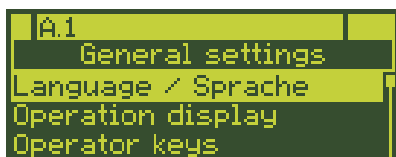

The A.1 Language / Sprache submenu is highlighted.

- ▼3x Select A.4 Key number submenu.

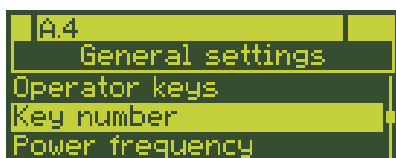

- 1x Enter A.4 Key number submenu.

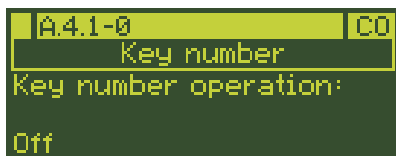

The A.4.1 Key number operation configuration item is displayed together with the currently active setting: A.4.1-0 = Off

- 1x Activate A.4.1 Key number operation configuration item.

The currently active setting is highlighted: Off.

- ▼1x Change setting to A.4.1-1 (On).

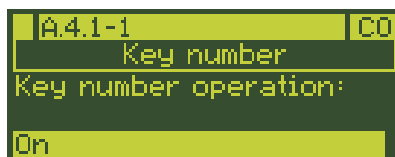

- 1x Confirm setting.

- ▼1x Select Key number parameter.

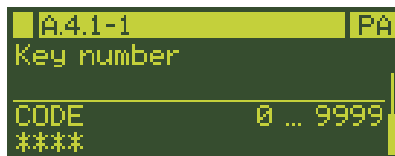

- 1x Activate Key number parameter. The current user key number (0 = default) is highlighted.



Operation

- △... Change the key number as required (ranging from 0 to 9999).



- 1x Confirm key number.



- ⏏4x Return to the operating level.

From now on, changes to control parameter settings in the operating menu and changes in the configuration menu can only be performed after the key number has been entered using the cursor key (△) and confirmed by pressing the enter key (□).

Deactivate key number operation

Key number operation is deactivated by setting A.4.1-0.

i Note

The overriding service key number is specified at the back of the printed mounting and operating instructions as well as in the printed document IP 6493 (Important Product Information), which is supplied with the device. This service key number allows configuration settings and parameters to be changed regardless of user key number operation.

To avoid the unauthorized use of the service key number, we recommend removing it from the mounting and operating instructions or IP 6495-2 and kept in a safe place

8.5 Data transmission

Data are transferred between the controller and the TROVIS-VIEW software using an infrared interface or RS-232/USB or RS-485/USB interface boards included in the accessories (see the 'Operation' section).

8.5.1 TROVIS-VIEW

TROVIS-VIEW provides a uniform user interface that allows users to configure and parameterize various SAMSON devices using device-specific database modules. The TROVIS 6495-2 device module can be downloaded free of charge from our website at ► www.samsongroup.com > SERVICE & SUPPORT > Downloads > TROVIS-VIEW. Further information on TROVIS-VIEW (e.g. system requirements) is available on our website and in the Data Sheet ► T 6661.

USB driver

A driver is required for direct communication with the controller over a USB port or using a USB to RS-232 adapter. Depending on the computer used, the USB to RS-232 adapter is additionally required for the infrared adapter, connecting cable RJ-12/D-sub 9 pin or modular adapter for memory pen-64.

– USB interface

The driver for the USB port is included in the TROVIS-VIEW installation file for TROVIS-VIEW version 4.42 and higher. It is automatically installed on installing the TROVIS-VIEW software under Windows® 8 and higher. Users are automatically prompted to install a driver after connection to the USB port of a computer for the first time when the software runs under Windows® 7. In this case, the driver must be installed manually. The driver can be downloaded from our website at ► www.samsunggroup.com > SERVICE & SUPPORT > Downloads > TROVIS-VIEW.

– USB to RS-232 adapter

The first time the USB to RS-232 adapter is connected to a computer, users are automatically prompted to install a driver. In this case, the driver must be installed manually. The driver can be downloaded from our website at ► www.samsunggroup.com > SERVICE & SUPPORT > Downloads > TROVIS-VIEW.

i Note

Further information on configuration and operation using the TROVIS-VIEW software is available in ► EB 6661.

An infrared interface is required for data transmission between the serial RS-232 port of the computer and the infrared interface on the controller (see Fig. 6-2).

A bracket ensures that the adapter is properly aligned in front of the controller. The infra-red adapter can be connected to the USB port of the computer using the USB to RS-232 adapter. A driver must be installed to use the adapter (see Annex B).

➔ Proceed as described in ► EB 6661.

The infrared adapter is only necessary for computers with a COM port (RS-232).

➔ To ensure data transmission functions properly, place the infrared adapter so that the distance to the infrared interface does not exceed 0.7 m and that the max. angle 25° is kept (see Fig. 6-2).

8.5.2 Infrared interface

The infrared interface allows the industrial controller to be configured and operated using the TROVIS-VIEW software. It can be accessed from the front of the controller. It is located above the SAMSON logo (see Fig. 6-1).

8.5.3 RS-232/USB interface board

Upgrading the controller with the optional RS-232/USB interface board (see Annex B) allows data transmission over the RJ-12 jack or over the USB port. In addition, a memory pen (see Annex B) can be inserted into the RJ-12 jack.

Operation

The RS-232/USB interface board includes one of the following interfaces:

- RS-232 interface (RJ-12 jack)
- USB interface (5-pin mini-B port) (slave)

The RS-485 data transfer uses an SSP or Modbus RTU protocol. The protocol of the RS-232 interface is set at the controller in the D.2.1 configuration item.

A USB cable (see the 'Operation' section) is used for data transmission between the USB interface and the USB port of the computer.

A connecting cable RJ-12/D-sub 9 pin (see the 'Operation' section) is used for data

transmission between the RS-232 interface and the COM port of the computer.

A connecting cable RJ-12/D-sub 9 pin and the USB to RS-232 adapter (see the 'Operation' section) are required for data transmission between the RS-232 interface and the USB port of the computer.

A driver must be installed to use the USB interface and the USB to RS-232 adapter (see the 'Start-up and configuration' section).

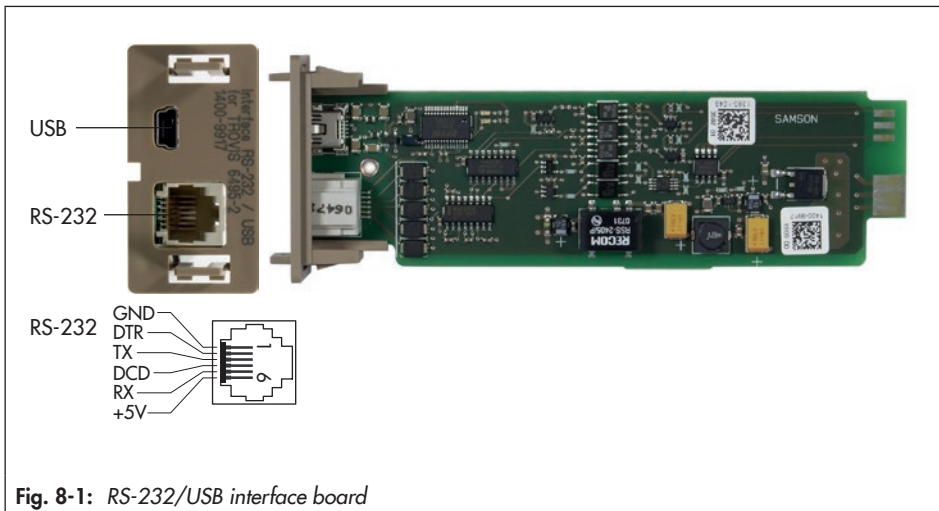

8.5.3.1 Memory pen

i Note

The memory pen-64 can only be used when the controller is fitted with a RS-232/USB interface board.

The memory pen-64 (see Fig. 8-2) serves as a data carrier and is able to load and save data (configuration, parameters) in its non-volatile memory.

The memory pen can be loaded with data configured in TROVIS-VIEW and the settings transferred to one or several controllers of the same type and version. In the same way, the memory pen can be used to upload data from the controller allowing you to simply copy the configuration data from one controller to another controller of the same type and version.



Fig. 8-2: Memory pen-64

8.5.3.2 Data transmission between the controller and memory pen

1. Insert the memory pen into the RJ-12 jack at the RS-232/USB board of the controller.

The following appears on the display when the controller recognizes the memory pen:



In the top row of the display, the device type assigned to the data contained on the memory pen is indicated. You can select whether the data from the controller are to be uploaded to the memory pen or whether the data from the memory pen are to be downloaded to the controller.

If the memory pen contains, for example, data from another device type, the option to download from the pen does not appear.

If the memory pen is write-protected, the option to upload data does not appear.

2. Select option (▲), (▼):

6495 >> Memory pen: Data are uploaded from the controller to the memory pen.

Memory pen >> 6495: Data are downloaded from the memory pen to the controller.

3. Confirm setting (□).

Data transmission starts.

The following display appears when data transmission is completed:



The memory pen can be removed.

8.5.4 RS-485/USB interface board

To integrate the controller into a communications network, the controller can be fitted with an optional RS-485/USB interface board (see Annex B). The USB connection can be used to transfer data using TROVIS-VIEW.

The RS-485/USB interface board includes one of the following interfaces:

- RS-485 interface (4 terminals)
- USB interface (5-pin mini-B port) (slave)

The RS-485 data transfer uses an SSP or Modbus RTU protocol. Slide switches are used to set the two-/four-wire operation and to activate bus termination.

The protocol and the parameters of the RS-485 interface is set at the controller in the D.3.1 configuration item.

A USB cable (see the 'Operation' section) is used for data transmission between the USB interface and the USB port of the computer.

A two-pin or four-pin shielded cable is used for data transmission between the RS-485 interface and a RS-485 port of a computer.

A driver must be installed to use the USB interface (▶ EB 6661).

TROVIS 6495-2	EIA-485 standard	Signal
AR	RB	Rx+
BR	RA	Rx-
BTR	TA	Tx-
ATR	TB	Tx+

i Note

The A/B naming of the RS-485 connectors corresponds to the naming used by various RS-485 chip manufacturers. Although this naming is in widespread use, it is in conflict with the naming used in the interface standard EIA-485, which specifies A as the inverting pin and B as the non-inverting pin.

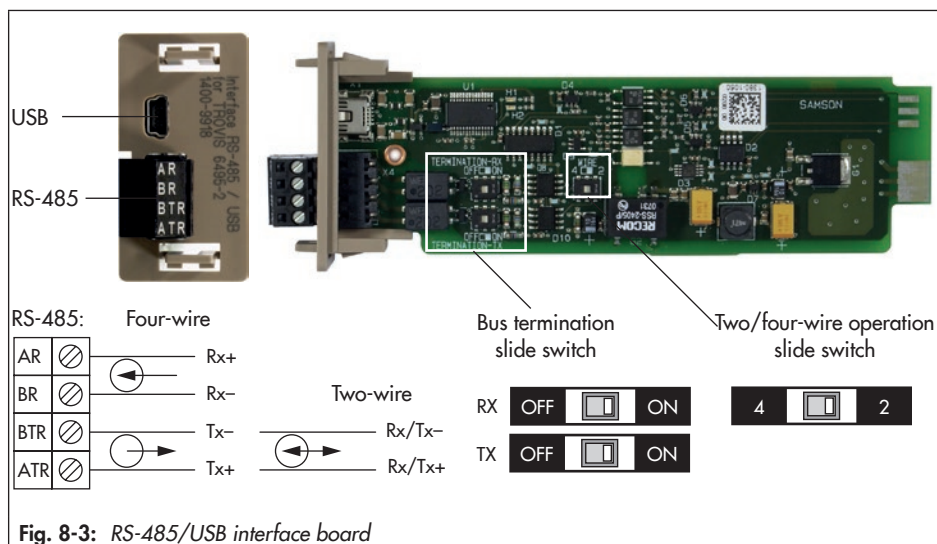
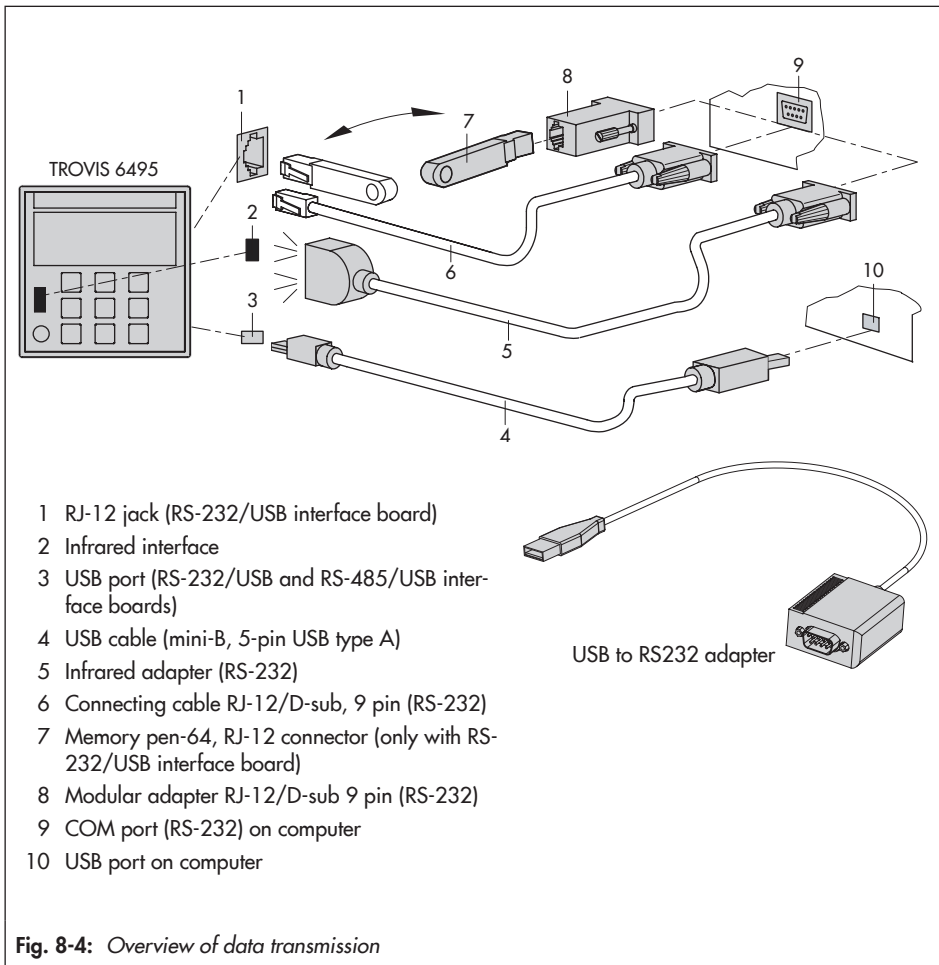

Fig. 8-3: RS-485/USB interface board

Operation



i Note

- The associated ordering numbers are listed in the annex.
- By using the USB to RS-232 adapter, the USB port of the computer can be used in place of the COM port (RS-232) when Windows® is installed on the computer.

9 Malfunctions

⚠ DANGER

Risk of electric shock while performing electrical connection.

For electrical installation, you are required to observe the relevant electrotechnical regulations of the country of use as well as the regulations of the local power suppliers.

→ Only allow properly trained and qualified personnel to perform the work.

ⓘ NOTICE



Risk of damage to the industrial controller due to incorrectly performed work.

→ Only properly trained personnel appropriately qualified to carry out such tasks must be allowed to perform corrective action.

9.1 Troubleshooting

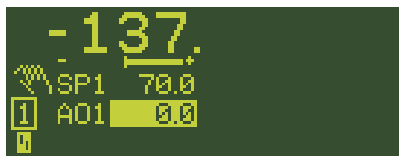
The fault alarm icon  is displayed and the digital output DO7 is activated when a fault alarm has been registered.



Possible sources of error are displayed in the info menu on selecting the Error messages menu item. If several errors exist, use the cursor keys (, ) to browse through the errors.

As soon as an error has been corrected, it is removed from the list of errors and is no longer displayed.

Incoming and outgoing error messages are time-stamped and saved in the last events list (see the 'Operation' section for the info menu).

The following list (see Table 9-1) contains error messages, possible causes and the recommended action.

Malfunctions

i Note

- We recommend for any errors not described in detail to switch off the power supply and to wait approx. five seconds before switching it on again.
- Contact SAMSON's After-sales Service for malfunctions not listed in the table.

The digital outputs DO5 and DO6 can be configured so that they are activated when a sensor/signal error or communication failure occurs. See O.10.1 or O.11.1 configuration item in Annex A.

Table 9-1: Error list

Error	Possible reasons	Recommended action
AI1(2, 3, 4) Wrong switch position	The position of the two DIP switches for the analog input configuration is not identical.	➔ Re-position DIP switches (see the 'Operation' section).
AI1(2, 3, 4) below range	The input signal is 5 % below the lower value of the nominal signal range.	➔ Check input signal setting. ➔ Check the sensor lead for sensor/wire breakage or for a short circuit.
AI1(2, 3, 4) above range	The input signal is 5 % above the upper value of the nominal signal range.	➔ Check electrical connection to terminal strip 1 (analog inputs). See the 'Installation' section.
C1(2)–SPC below range	The given set point is lower than the lower measuring range value AI1(2, 3, 4).MIN of the analog input assigned to the controlled variable PV.	➔ Check value.
C1(2)–SPC above range	The given set point is higher than the upper measuring range value AI1(2, 3, 4).MAX of the analog input assigned to the controlled variable PV.	➔ Check value.
Internal temperature Sensor defective	The sensor for monitoring the temperature inside the controller is defective.	➔ Replace the device.

Error	Possible reasons	Recommended action
Internal temperature Temperature too low (-5 °C)	The permissible ambient temperature range between 0 and 50 °C has not been kept.	<ul style="list-style-type: none"> ➔ Check the ambient temperature. ➔ Check location of installation.
Internal temperature Temperature too high (65 °C)		
Communication failure AI1(2, 3, 4) timeout	No write access given within the timeout for the signal monitoring of the interface assigned to an analog input.	<ul style="list-style-type: none"> ➔ Check timeout setting (AI1(2, 3, 4).TOUT parameter in I.1(2, 3, 4).1 configuration item. ➔ Check interface (see the 'Operation' section).
Communication failure C1(2)-SPC timeout	No write access given within the timeout for the signal monitoring of the interface assigned to Controller [1] or [2].	<ul style="list-style-type: none"> ➔ Check timeout setting (SPC.TOUT parameter in C.2.1.6 configuration item). ➔ Check interface (see the 'Operation' section).

9.2 Emergency action

The control function no longer works after device failure. In this case, isolate and shut-off valves.

Plant operators are responsible for emergency action to be taken in the plant.



Tip

Emergency action in the event of valve failure is described in the associated valve documentation.

10 Servicing

The work described in this section is only to be performed by personnel appropriately qualified to carry out such tasks.

We recommend inspection and testing according to Table 10-1.

i Note

The industrial controller was checked by SAMSON before delivery.

- *The product warranty becomes void if service or repair work not described in these instructions is performed without prior agreement by SAMSON's After-sales Service.*
- *Only use original spare parts by SAMSON, which comply with the original specifications.*

Table 10-1: Recommended inspection and testing

Inspection and testing	Action to be taken in the event of a negative result
Check the markings, labels and nameplates on the industrial controller for their readability and completeness.	➔ Immediately renew damaged, missing or incorrect nameplates or labels.
	➔ Clean any inscriptions that are covered with dirt and are illegible.
Check the connecting cables.	➔ If lines are loose, tighten the screws at the terminal (see the 'Installation' section).
	➔ Renew damaged lines.
Check the plug-on screw terminals to ensure they are correctly inserted.	➔ Insert plug-on screw terminals that are not correctly inserted (see the 'Installation' section).
Check panel mounting.	➔ If the device is mounted too loosely or too tightly, adjust the threaded rods (see the 'Installation' section).
	➔ Replace a defective seal.

11 Decommissioning

The work described in this section is only to be performed by personnel appropriately qualified to carry out such tasks.

DANGER

Risk of electric shock while performing electrical connection.

For electrical installation, you are required to observe the relevant electrotechnical regulations of the country of use as well as the regulations of the local power suppliers.

- *Before connecting wiring, performing any work on the industrial controller or opening the controller, disconnect the supply voltage and protect it against unintentional reconnection.*
 - *Only use power interruption devices that can be protected against unintentional reconnection of the power supply.*
 - *Do not remove any covers to perform adjustment work on live parts.*
-

To put the industrial controller out of operation, the controller must be disconnected from the electrical power supply:

- Disconnect the supply voltage and protect it against unintentional reconnection.
- Make sure that the terminals of the inputs and outputs are de-energized.

12 Removal

The work described in this section is only to be performed by personnel appropriately qualified to carry out such tasks.

1. Pull off terminal strips.
2. Unscrew the threaded rods of the mounting clamps using a screwdriver.
3. Remove the mounting clamps.
4. Pull the controller out of the panel cut-out.

13 Repairs

A defective industrial controller must be repaired or replaced.

NOTICE

Risk of controller damage due to incorrect service or repair work.

- *Do not perform any repair work on your own.*
 - *Contact SAMSON's After-sales Service for service and repair work.*
-

13.1 Returning devices to SAMSON

Defective industrial controllers can be returned to SAMSON for repair.

Proceed as follows to return devices to SAMSON:

1. Put the industrial controller out of operation (see the 'Decommissioning' section).
2. Remove the industrial controller (see the 'Removal' section).
3. Proceed as described on the Returning goods page of our website
 - ▶ www.samsongroup.com > Service & Support > After-sales Service > Returning goods

14 Disposal

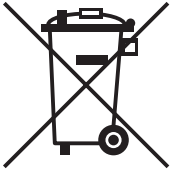

SAMSON is a producer registered at the following European institution
▶ <https://www.ewrn.org/national-registers/national-registers>.
WEEE reg. no.:
DE 62194439/FR 025665

- Observe local, national and international refuse regulations.
- Do not dispose of components, lubricants and hazardous substances together with your other household waste.

i Note

We can provide you with a recycling passport according to PAS 1049 on request. Simply e-mail us at aftersaleservice@samsongroup.com giving details of your company address.

Tip

On request, we can appoint a service provider to dismantle and recycle the product as part of a distributor take-back scheme.

15 Certificates

The following certificates are included on the next pages:

- EU declaration of conformity
- TR CU certificate

The certificates shown were up to date at the time of publishing. The latest certificates can be found on our website:

▶ www.samsongroup.com > Products & Applications > Product selector > Automation Systems > 6495-2

EU declaration of conformity

SMART IN FLOW CONTROL



SAMSON

**EU Konformitätserklärung / EU Declaration of Conformity /
Déclaration UE de conformité**

Die alleinige Verantwortung für die Ausstellung dieser Konformitätserklärung trägt der Hersteller/
This declaration of conformity is issued under the sole responsibility of the manufacturer/
La présente déclaration de conformité est établie sous la seule responsabilité du fabricant.
Für das folgende Produkt / For the following product / Nous certifions que le produit

**Industrieregler / Industrial Controller / Régulateur industriel
Typ/Type/Type TROVIS 6495**

wird die Konformität mit den einschlägigen Harmonisierungsrechtsvorschriften der Union bestätigt/
the conformity with the relevant Union harmonisation legislation is declared with/
est conforme à la législation d'harmonisation de l'Union applicable selon les normes:

EMC 2014/30/EU	EN 61000-6-2:2005, EN 61000-6-3:2010 +A1:2011, EN 61326:2013
LVD 2014/35/EU	EN 60730-1:2016, EN 61010-1:2010
RoHS 2011/65/EU	EN 50581:2012

Hersteller / Manufacturer / Fabricant:

SAMSON AKTIENGESELLSCHAFT
Weismüllerstraße 3
D-60314 Frankfurt am Main
Deutschland/Germany/Allemagne

Frankfurt / Francfort, 2017-07-29
Im Namen des Herstellers/ On behalf of the Manufacturer/ Au nom du fabricant.

 _____ Gert Nahler Zentralabteilungsleiter/Head of Department/Chef du département Entwicklung Automation und Integrationstechnologien/ Development Automation and Integration Technologies	 _____ Hanno Zager Leiter Qualitätssicherung/Head of Quality Management/ Responsable de l'assurance de la qualité
--	--

SAMSON AKTIENGESELLSCHAFT
Weismüllerstraße 3 60314 Frankfurt am Main

Telefon: 069 4009-0 · Telefax: 069 4009-1507
E-Mail: samson@samson.de

Revision 07

ce_5495-0_de_en_fr_07.pdf

TR CU certificate

ЕВРАЗИЙСКИЙ ЭКОНОМИЧЕСКИЙ СОЮЗ	
СЕРТИФИКАТ СООТВЕТСТВИЯ	
№ ЕАЭС RU C-DE.3A11.B.00051/19	
Серия RU № 0197360	
<p>ОРГАН ПО СЕРТИФИКАЦИИ Общества с ограниченной ответственностью «ТМС РУС» Место нахождения (адрес юридического лица): Российская Федерация, 127083, город Москва, улица Верхняя Масловка, дом 20, строение 2; адрес места осуществления деятельности: Российская Федерация, 127083, город Москва, улица Верхняя Масловка, дом 20, строение 2, помещения № 18, 28. Аттестат аккредитации № РОСС RU.0001.113А11 от 02.07.2015. Номер телефона: +7 (495) 221-18-04; адрес электронной почты: info@tms-cs.ru.</p>	
<p>ЗАЯВИТЕЛЬ Общество с ограниченной ответственностью «Самсон Контролс». Место нахождения (адрес юридического лица) и адрес места осуществления деятельности: Российская Федерация, 109544, город Москва, бульвар Энтузиастов, дом 2, этаж 5, комната 11. ОГРН 1037700041026. Номер телефона: +7 (495) 777-45-45; адрес электронной почты: samson@samson.ru.</p>	
<p>ИЗГОТОВИТЕЛЬ «SAMSON AG Mess- und Regeltechnik» Место нахождения (адрес юридического лица) и адрес места осуществления деятельности по изготовлению продукции: Weismullerstrasse 3, D-60314 Frankfurt am Main, Германия.</p>	
<p>ПРОДУКЦИЯ Регуляторы электронные систем локального и центрального отопления, регуляторы промышленные TROVIS, типы 5573, 5575, 5576, 5579, 5610, 6493, 6495. Изготовление в соответствии со стандартами, указанными в приложении к сертификату соответствия на бланке № 0676636. Серийный выпуск.</p>	
<p>КОД ТН ВЭД ЕАЭС 9032 89 000 0</p>	
<p>СООТВЕТСТВУЕТ ТРЕБОВАНИЯМ технических регламентов Таможенного союза «О безопасности низковольтного оборудования» (ТР ТС 004/2011), «Электромагнитная совместимость технических средств» (ТР ТС 020/2011).</p>	
<p>СЕРТИФИКАТ СООТВЕТСТВИЯ ВЫДАН НА ОСНОВАНИИ протокола сертификационных испытаний № 190919-008-009-02/ИР от 28.10.2019, выданного испытательной лабораторией Общества с ограниченной ответственностью «Иновационные решения», аттестат аккредитации РОСС RU.0001.21AB90; акта о результатах анализа состояния производства № 00062-А от 04.07.2019 органа по сертификации Общества с ограниченной ответственностью «ТМС РУС»; руководства по эксплуатации 4218-5570-5610-6490-2018.РЭ. Схема сертификации – 1с.</p>	
<p>ДОПОЛНИТЕЛЬНАЯ ИНФОРМАЦИЯ Стандарты, в результате применения которых на добровольной основе обеспечивается соблюдение требований технических регламентов, указаны в приложении к сертификату соответствия на бланке № 0676637. Назначенный срок службы – 12 лет. Назначенный срок хранения – 2 года. Условия хранения указаны в руководстве по эксплуатации 4218-5570-5610-6490-2018.РЭ.</p>	
<p>СРОК ДЕЙСТВИЯ С 25.12.2019</p>	<p>ПО 24.12.2024</p>
<p>ВКЛЮЧИТЕЛЬНО</p>	
<p>Руководитель (уполномоченное лицо) органа по сертификации</p>	<p>Назарова Лилия Юрьевна М.П. (Ф.И.О.)</p>
<p>Эксперт (эксперт-аудитор) (эксперты (эксперты-аудиторы))</p>	<p>Ходоров Владимир Игоревич (Ф.И.О.)</p>

ЕВРАЗИЙСКИЙ ЭКОНОМИЧЕСКИЙ СОЮЗ

ПРИЛОЖЕНИЕ

К СЕРТИФИКАТУ СООТВЕТСТВИЯ № ЕАЭС RU C-DE.ЭА11.В.00051/19

Серия **RU** № **0676636** Лист 1 из 1

Стандарты, в соответствии с которыми изготавливается продукция

Обозначение стандарта	Наименование стандарта
IEC 60730-1:2013 / Cor. 1:2014	Automatic electrical controls for household and similar use. Part 1. General requirements. Corrigendum 1
EN 50344-1:2002	Routine tests for controls within the scope of the EN 60730 series. General requirements
EN 55032:2012	Electromagnetic compatibility of multimedia equipment - Emission requirements
EN 61000-6-1:2007	Electromagnetic compatibility (EMC) - Part 6-1: Generic standards - Immunity for residential, commercial and light-industrial environments
IEC 61000-6-2:2016	Electromagnetic compatibility (EMC). Part 6-2: Generic standards. Immunity for industrial environments
EN 61000-6-3:2007	Electromagnetic compatibility (EMC). Part 6-3: Generic standards. Emission standard for residential, commercial and light-industrial environments
IEC 61010-1:2010	Safety requirements for electrical equipment for measurement, control, and laboratory use. Part 1: General requirements
EN 61326-1:2013	Electrical equipment for measurement, control and laboratory use. EMC requirements. Part 1: General requirements

Руководитель (уполномоченное
лицо) органа по сертификации

Л.И. Назорова
(подпись)

Назорова Лилия Юрьевна

(Ф.И.О.)

Эксперт (эксперт-аудитор)
(эксперты (эксперты-аудиторы))

М.П.

Ходоров Владимир Игоревич

(Ф.И.О.)



ЕВРАЗИЙСКИЙ ЭКОНОМИЧЕСКИЙ СОЮЗ

ПРИЛОЖЕНИЕ

К СЕРТИФИКАТУ СООТВЕТСТВИЯ № ЕАЭС RU C-DE ЭА11.В.00051/19

Серия **RU** № **0676637** Лист 2 из 2

Стандарты, в результате применения которых на добровольной основе обеспечивается соблюдение требований технического регламента

Обозначение стандарта	Наименование стандарта
ГОСТ IEC 61010-1-2014	Безопасность электрических контрольно-измерительных приборов и лабораторного оборудования. Часть 1. Общие требования
ГОСТ Р 51522.1-2011 (МЭК 61326-1:2005) подразделы 6.2 и 7.2	Электрическое оборудование для измерения, управления и лабораторного применения. Часть 1. Общие требования и методы испытаний
ГОСТ 30804.6.1-2013 (IEC 61000-6-1:2005) раздел 8	Совместимость технических средств электромагнитная. Устойчивость к электромагнитным помехам технических средств, применяемых в жилых, коммерческих зонах и производственных зонах с малым энергопотреблением. Требования и методы испытаний
ГОСТ 30804.6.3-2013 (IEC 61000-6-3:2006) раздел 7	Совместимость технических средств электромагнитная. Электромагнитные помехи от технических средств, применяемых в жилых, коммерческих зонах и производственных зонах с малым энергопотреблением. Нормы и методы испытаний

Руководитель (уполномоченное лицо) органа по сертификации

Эксперт (эксперт-аудитор) (эксперты (эксперты-аудиторы))

Игорь
(подпись)



Назарова Лилия Юрьевна (Ф.И.О.)

Ходоров Владимир Игоревич (Ф.И.О.)

16 Annex A (configuration guide)

16.1 Abbreviations

Abbreviation	Meaning
AI	Analogeingang (Analog Input)
AO	Analogausgang (Analog Output)
DI	Digitaleingang (Digital Input)
DO	Digitalausgang (Digital Output)
DV	Auxiliary variable, disturbance variable or leading process variable in ratio control
e	Error
FB	Position feedback
KP	Proportional-action coefficient
PV	Process variable
PVO	Actual value at comparator
PVR	Process Variable Ratio
PWM	Pulse width modulation
SO	Switching output
SP	Set point
SP1...4	Set point 1...4
SPI	Internal set point
SPO	Set point at comparator
SPC	Set point via interface
SPE	External set point, auxiliary variable, disturbance variable
SPM	Set point of slave controller (cascade control) (Set Point from Master)
SPR	Set Point Ratio
TN	Reset time
TR	Input variable for output tracking, auxiliary variable, disturbance variable
TRC	Output tracking via interface
TV	Derivative-action time
TV.K	Derivative-action gain
Y	Manipulated variable
YO	Operating point
YM	Output variable of master controller (cascade control)

16.2 Configuration list · Functions and parameters

Information on the configuration list

Some functions and parameters can only be selected after certain initial settings have been made beforehand. The initial settings required are specified in angle brackets in the following list. A comma represents “and” and a slash represents “or” in the following list.

Example: <M.1-5/-6, I.3.50>: Either the configuration M.1-5 and I.3.50 or the configuration M.1-6 and I.3.50 must initially be set.

M Control mode

NOTICE! Changing the control mode causes the controller to be reset to its default settings.		Default setting	Setting
M.1	Control mode	M.1.1-1	
-1	1x Fixed set point/follow-up control		
-2	Ratio control		
-3	Cascade control		
-4	Override control		
-5	2x Fixed set point/follow-up control		
-6	Ratio control + Controller		

I Input

I.1	Analog input AI1	Default setting	Setting
I.1.1	Input signal	I.1.1-6	
-1	4–20 mA <both DIP switches on right: mA/V>		
-2	0–20 mA <both DIP switches on right: mA/V>		
-3	0–10 V <both DIP switches on right: mA/V>		
-4	2–10 V <both DIP switches on right: mA/V>		
-5	Via interface		
-6	Pt 100 <both DIP switches on left: Pt 100/Pt 1000>		
-7	Pt 1000 <both DIP switches on left: Pt 100/Pt 1000>		
AI1.MIN	Lower measuring range value [-999.0...9999.0]	0.0	
AI1.MAX	Upper measuring range value [-999.0...9999.0]	100.0	
AI1.K1	Initial value <I.1.1-5> · Default value <I.1.5-2> [-999.0...9999.0]	0.0	

I.1	Analog input AI1	Default setting	Setting
I.1.2	Decimal point	I.1.2-1	
-0	XXXX	No decimal place	
-1	XXX.X	1 decimal place	
-2	XX.XX	2 decimal places	
-3	X.XXX	3 decimal places	
I.1.3	Physical unit	I.1.3-1	
-0	Off	<not with I.1.1-6/-7>	
-1	°C	Temperature	
-2	°F	Temperature	
-3	K	Temperature	<not with I.1.1-6/-7>
-4	bar	Pressure	<not with I.1.1-6/-7>
-5	mbar	Pressure	<not with I.1.1-6/-7>
-6	psi	Pressure	<not with I.1.1-6/-7>
-7	kPa	Pressure	<not with I.1.1-6/-7>
-8	m ³ /h	Flow rate	<not with I.1.1-6/-7>
-9	l/h	Flow rate	<not with I.1.1-6/-7>
-10	ft ³ /h	Flow rate	<not with I.1.1-6/-7>
-11	kg/h	Mass flow	<not with I.1.1-6/-7>
-12	t/h	Mass flow	<not with I.1.1-6/-7>
-13	lb/h	Mass flow	<not with I.1.1-6/-7>
-14	%		<not with I.1.1-6/-7>
-15	mFS	Filling level	<not with I.1.1-6/-7>
-16	mmFS	Filling level	<not with I.1.1-6/-7>
-17	inH ₂ O	Filling level (inch water column)	<not with I.1.1-6/-7>
-18	%rF	Relative humidity	<not with I.1.1-6/-7>
-19	kg/m ³	Density	<not with I.1.1-6/-7>
-20	pH	pH	<not with I.1.1-6/-7>
I.1.4	Input signal increase/decrease	I.1.4-0	
-0	Off		
-1	On		
AI1.COR	Correction value <I.1.4-1>	[−999.0...9999.0]	0.0
I.1.5	Signal monitoring	I.1.5-0	
-0	Off		
-1	On		
-2	On (with default value)		
AI1.K1	Default value <I.1.5-2> · Initial value <I.1.1-5>	[−999.0...9999.0]	
AI1.TOUT	Timeout interface <I.1.1-5, I.1.5≠0>	[1...99999 s]	

Annex A (configuration guide)

I.1	Analog input AI1		Default setting	Setting
I.1.6	Manual mode Controller [1] upon signal failure <I.1.5≠0>		I.1.6-0	
-0	Off			
-1	Constant output value at AO1 <O.1.1-1>			
-2	Constant output value at AO2 <O.2.1-1>			
-3	Constant output value at AO3 <O.3.1-1>			
-4	Constant output value at AO1 <O.4.1-1>			
-5	Constant output value at SO2 <O.5.1-1>			
-6	With last output value <O.1.1-1/O.2.1-1/O.3.1-1/O.4.1-1/O.5.1-1>			
AO1.K1	Constant output value at AO1 <I.1.6-1>	[-10.0 ... 110.0 %]	0.0 %	
AO2.K1	Constant output value at AO2 <I.1.6-2>	[-10.0 ... 110.0 %]	0.0 %	
AO3.K1	Constant output value at AO3 <I.1.6-3>	[-10.0 ... 110.0 %]	0.0 %	
SO1.K1	Constant output value at SO1 <I.1.6-4>	[-10.0 ... 110.0 %]	0.0 %	
SO2.K1	Constant output value at SO2 <I.1.6-5>	[-10.0 ... 110.0 %]	0.0 %	
I.1.7	Manual mode Controller [2] upon signal failure <M.1-5/-6, I.1.5≠0>		I.1.7-0	
-0	Off			
-1	Constant output value at AO1 <O.1.1-2>			
-2	Constant output value at AO2 <O.2.1-2>			
-3	Constant output value at AO3 <O.3.1-2>			
-4	Constant output value at AO1 <O.4.1-2>			
-5	Constant output value at SO2 <O.5.1-2>			
-6	With last output value <O.1.1-2/O.2.1-2/O.3.1-2/O.4.1-2/O.5.1-2>			
AO1.K1	Constant output value at AO1 <I.1.7-1>	[-10.0 ... 110.0 %]	0.0 %	
AO2.K1	Constant output value at AO2 <I.1.7-2>	[-10.0 ... 110.0 %]	0.0 %	
AO3.K1	Constant output value at AO3 <I.1.7-3>	[-10.0 ... 110.0 %]	0.0 %	
SO1.K1	Constant output value at SO1 <I.1.7-4>	[-10.0 ... 110.0 %]	0.0 %	
SO2.K1	Constant output value at SO2 <I.1.7-5>	[-10.0 ... 110.0 %]	0.0 %	

I.2	Analog input AI2	Default setting	Setting
I.2.1	Input signal	I.2.1-6	
-1	4–20 mA <both DIP switches on right: mA/V>		
-2	0–20 mA <both DIP switches on right: mA/V>		
-3	0–10 V <both DIP switches on right: mA/V>		
-4	2–10 V <both DIP switches on right: mA/V>		
-5	Via interface		
-6	Pt 100 <both DIP switches on left: Pt 100/Pt 1000/potentiometer>		
-7	Pt 1000 <both DIP switches on left: Pt 100/Pt 1000/potentiometer>		
-8	Potentiometer 100 Ω <both DIP switches on left: Pt 100/Pt 1000/potentiometer>		
-9	Potentiometer 200 Ω <both DIP switches on left: Pt 100/Pt 1000/potentiometer>		
-10	Potentiometer 500 Ω <both DIP switches on left: Pt 100/Pt 1000/potentiometer>		
-11	Potentiometer 1000 Ω <both DIP switches on left: Pt 100/Pt 1000/potentiometer>		
AI2.MIN	Lower measuring range value [-999.0... 9999.0]	0.0	
AI2.MAX	Upper measuring range value [-999.0... 9999.0]	100.0	
AI2.K1	Initial value <I.2.1-5> · Default value <I.2.5-2> [-999.0... 9999.0]	0.0	
I.2.2	Decimal point	I.2.2-1	
-0	XXXX No decimal place		
-1	XXX.X 1 decimal place		
-2	XX.XX 2 decimal places		
-3	X.XXX 3 decimal places		
I.2.3	Physical unit	I.2.3-1	
-0	Off <not with I.2.1-6/-7>		
-1	°C Temperature		
-2	°F Temperature		
-3	K Temperature <not with I.2.1-6/-7>		
-4	bar Pressure <not with I.2.1-6/-7>		
-5	mbar Pressure <not with I.2.1-6/-7>		
-6	psi Pressure <not with I.2.1-6/-7>		
-7	kPa Pressure <not with I.2.1-6/-7>		
-8	m ³ /h Flow rate <not with I.2.1-6/-7>		
-9	l/h Flow rate <not with I.2.1-6/-7>		
-10	ft ³ /h Flow rate <not with I.2.1-6/-7>		
-11	kg/h Mass flow <not with I.2.1-6/-7>		
-12	t/h Mass flow <not with I.2.1-6/-7>		
-13	lb/h Mass flow <not with I.2.1-6/-7>		
-14	% <not with I.2.1-6/-7>		
-15	mFS Filling level <not with I.2.1-6/-7>		

Annex A (configuration guide)

I.2	Analog input AI2			Default setting	Setting
-16	mmFS	Filling level	<not with I.2.1-6/-7>		
-17	inH ₂ O	Filling level (inch water column)	<not with I.2.1-6/-7>		
-18	%rF	Relative humidity	<not with I.2.1-6/-7>		
-19	kg/m ³	Density	<not with I.2.1-6/-7>		
-20	pH	pH	<not with I.2.1-6/-7>		
I.2.4	Input signal increase/decrease			I.2.4-0	
-0	Off				
-1	On				
AI2.COR	Correction value <I.2.4-1>		[-999.0...9999.0]	0.0	
I.2.5	Signal monitoring			I.2.5-0	
-0	Off				
-1	On				
-2	On (with default value)				
AI2.K1	Default value <I.2.5-2> · Initial value <I.2.1-5>		[-999.0...9999.0]	0.0	
AI2.TOUT	Timeout interface <I.2.1-5, I.2.5≠0>		[1...99999 s]	60 s	
I.2.6	Manual mode Controller [1] upon signal failure <I.2.5≠0>			I.2.6-0	
-0	Off				
-1	Constant output value at AO1		<O.1.1-1>		
-2	Constant output value at AO2		<O.2.1-1>		
-3	Constant output value at AO3		<O.3.1-1>		
-4	Constant output value at AO1		<O.4.1-1>		
-5	Constant output value at SO2		<O.5.1-1>		
-6	With last output value		<O.1.1-1/O.2.1-1/O.3.1-1/O.4.1-1/O.5.1-1>		
AO1.K1	Constant output value at AO1 <I.2.6-1>		[-10.0 ... 110.0 %]	0.0 %	
AO2.K1	Constant output value at AO2 <I.2.6-2>		[-10.0 ... 110.0 %]	0.0 %	
AO3.K1	Constant output value at AO3 <I.2.6-3>		[-10.0 ... 110.0 %]	0.0 %	
SO1.K1	Constant output value at SO1 <I.2.6-4>		[-10.0 ... 110.0 %]	0.0 %	
SO2.K1	Constant output value at SO2 <I.2.6-5>		[-10.0 ... 110.0 %]	0.0 %	
I.2.7	Manual mode Controller [2] upon signal failure			I.2.7-0	
	<M.1-5/-6, I.2.5≠0>				
-0	Off				
-1	Constant output value at AO1		<O.1.1-2>		
-2	Constant output value at AO2		<O.2.1-2>		
-3	Constant output value at AO3		<O.3.1-2>		
-4	Constant output value at AO1		<O.4.1-2>		
-5	Constant output value at SO2		<O.5.1-2>		

I.2	Analog input AI2	Default setting	Setting
-6	With last output value <0.1.1-2/0.2.1-2/0.3.1-2/ 0.4.1-2/0.5.1-2>		
AO1.K1	Constant output value at AO1 <I.2.7-1> [-10.0 ... 110.0 %]	0.0 %	
AO2.K1	Constant output value at AO2 <I.2.7-2> [-10.0 ... 110.0 %]	0.0 %	
AO3.K1	Constant output value at AO3 <I.2.7-3> [-10.0 ... 110.0 %]	0.0 %	
SO1.K1	Constant output value at SO1 <I.2.7-4> [-10.0 ... 110.0 %]	0.0 %	
SO2.K1	Constant output value at SO2 <I.2.7-5> [-10.0 ... 110.0 %]	0.0 %	

I.3	Analog input AI3	Default setting	Setting
I.3.1	Input signal	I.3.1-1	
-1	4-20 mA <both DIP switches on right: mA/V>		
-2	0-20 mA <both DIP switches on right: mA/V>		
-3	0-10 V <both DIP switches on right: mA/V>		
-4	2-10 V <both DIP switches on right: mA/V>		
-5	Via interface		
-6	Pt 100 <both DIP switches on left: Pt 100/Pt 1000>		
-7	Pt 1000 <both DIP switches on left: Pt 100/Pt 1000>		
AI3.MIN	Lower measuring range value [-999.0... 9999.0]	0.0	
AI3.MAX	Upper measuring range value [-999.0... 9999.0]	100.0	
AI3.K1	Initial value <I.3.1-5> · Default value <I.3.5-2> [-999.0... 9999.0]	0.0	
I.3.2	Decimal point	I.3.2-1	
-0	XXXX No decimal place		
-1	XXX.X 1 decimal place		
-2	XX.XX 2 decimal places		
-3	X.XXX 3 decimal places		
I.3.3	Physical unit	I.3.3-0	
-0	Off <not with I.3.1-6/-7>		
-1	°C Temperature		
-2	°F Temperature		
-3	K Temperature <not with I.3.1-6/-7>		
-4	bar Pressure <not with I.3.1-6/-7>		
-5	mbar Pressure <not with I.3.1-6/-7>		
-6	psi Pressure <not with I.3.1-6/-7>		
-7	kPa Pressure <not with I.3.1-6/-7>		
-8	m³/h Flow rate <not with I.3.1-6/-7>		
-9	l/h Flow rate <not with I.3.1-6/-7>		
-10	ft³/h Flow rate <not with I.3.1-6/-7>		
-11	kg/h Mass flow <not with I.3.1-6/-7>		

Annex A (configuration guide)

I.3	Analog input AI3	Default setting	Setting
-12	f/h Mass flow	<not with I.3.1-6/-7>	
-13	lb/h Mass flow	<not with I.3.1-6/-7>	
-14	%	<not with I.3.1-6/-7>	
-15	mFS Filling level	<not with I.3.1-6/-7>	
-16	mmFS Filling level	<not with I.3.1-6/-7>	
-17	inH ₂ O Filling level (inch water column)	<not with I.3.1-6/-7>	
-18	%rF Relative humidity	<not with I.3.1-6/-7>	
-19	kg/m ³ Density	<not with I.3.1-6/-7>	
-20	pH pH	<not with I.3.1-6/-7>	
I.3.4	Input signal increase/decrease	I.3.4-0	
-0	Off		
-1	On		
AI3.COR	Correction value <I.3.4-1>	[-999.0...9999.0]	0.0
I.3.5	Signal monitoring	I.3.5-0	
-0	Off		
-1	On		
-2	On (with default value)		
AI3.K1	Default value <I.3.5-2> · Initial value <I.3.1-5>	[-999.0...9999.0]	0.0
AI3.TOUT	Timeout interface <I.3.1-5, I.3.5≠0>	[1...99999 s]	60 s
I.3.6	Manual mode Controller [1] upon signal failure <I.3.5≠0>	I.3.6-0	
-0	Off		
-1	Constant output value at AO1	<O.1.1-1>	
-2	Constant output value at AO2	<O.2.1-1>	
-3	Constant output value at AO3	<O.3.1-1>	
-4	Constant output value at AO1	<O.4.1-1>	
-5	Constant output value at SO2	<O.5.1-1>	
-6	With last output value	<O.1.1-1/O.2.1-1/O.3.1-1/O.4.1-1/O.5.1-1>	
AO1.K1	Constant output value at AO1 <I.3.6-1>	[-10.0 ... 110.0 %]	0.0 %
AO2.K1	Constant output value at AO2 <I.3.6-2>	[-10.0 ... 110.0 %]	0.0 %
AO3.K1	Constant output value at AO3 <I.3.6-3>	[-10.0 ... 110.0 %]	0.0 %
SO1.K1	Constant output value at SO1 <I.3.6-4>	[-10.0 ... 110.0 %]	0.0 %
SO2.K1	Constant output value at SO2 <I.3.6-5>	[-10.0 ... 110.0 %]	0.0 %

I.3	Analog input AI3	Default setting	Setting
I.3.7	Manual mode Controller [2] upon signal failure <M.1-5/-6, I.3.5≠0>	I.3.7-0	
-0	Off		
-1	Constant output value at AO1 <O.1.1-2>		
-2	Constant output value at AO2 <O.2.1-2>		
-3	Constant output value at AO3 <O.3.1-2>		
-4	Constant output value at AO1 <O.4.1-2>		
-5	Constant output value at SO2 <O.5.1-2>		
-6	With last output value <O.1.1-2/O.2.1-2/O.3.1-2/ O.4.1-2/O.5.1-2>		
AO1.K1	Constant output value at AO1 <I.3.7-1> [-10.0 ... 110.0 %]	0.0 %	
AO2.K1	Constant output value at AO2 <I.3.7-2> [-10.0 ... 110.0 %]	0.0 %	
AO3.K1	Constant output value at AO3 <I.3.7-3> [-10.0 ... 110.0 %]	0.0 %	
SO1.K1	Constant output value at SO1 <I.3.7-4> [-10.0 ... 110.0 %]	0.0 %	
SO2.K1	Constant output value at SO2 <I.3.7-5> [-10.0 ... 110.0 %]	0.0 %	
I.4	Analog input AI4	Default setting	Setting
I.4.1	Input signal	I.4.1-1	
-1	4-20 mA <both DIP switches on right: mA/V>		
-2	0-20 mA <both DIP switches on right: mA/V>		
-3	0-10 V <both DIP switches on right: mA/V>		
-4	2-10 V <both DIP switches on right: mA/V>		
-5	Via interface		
-6	Pt 100 <both DIP switches on left: Pt 100/Pt 1000>		
-7	Pt 1000 <both DIP switches on left: Pt 100/Pt 1000>		
AI4.MIN	Lower measuring range value [-999.0... 9999.0]	0.0	
AI4.MAX	Upper measuring range value [-999.0... 9999.0]	100.0	
AI4.K1	Initial value <I.4.1-5> · Default value <I.4.5-2> [-999.0... 9999.0]	0.0	
I.4.2	Decimal point	I.4.2-1	
-0	XXXX No decimal place		
-1	XXX.X 1 decimal place		
-2	XX.XX 2 decimal places		
-3	X.XXX 3 decimal places		

Annex A (configuration guide)

I.4	Analog input AI4	Default setting	Setting
I.4.3	Physical unit	I.4.3-0	
-0	Off	<not with I.4.1-6/-7>	
-1	°C Temperature		
-2	°F Temperature		
-3	K Temperature	<not with I.4.1-6/-7>	
-4	bar Pressure	<not with I.4.1-6/-7>	
-5	mbar Pressure	<not with I.4.1-6/-7>	
-6	psi Pressure	<not with I.4.1-6/-7>	
-7	kPa Pressure	<not with I.4.1-6/-7>	
-8	m³/h Flow rate	<not with I.4.1-6/-7>	
-9	l/h Flow rate	<not with I.4.1-6/-7>	
-10	ft³/h Flow rate	<not with I.4.1-6/-7>	
-11	kg/h Mass flow	<not with I.4.1-6/-7>	
-12	t/h Mass flow	<not with I.4.1-6/-7>	
-13	lb/h Mass flow	<not with I.4.1-6/-7>	
-14	% <not with I.4.1-6/-7>	<not with I.4.1-6/-7>	
-15	mFS Filling level	<not with I.4.1-6/-7>	
-16	mmFS Filling level	<not with I.4.1-6/-7>	
-17	inH₂O Filling level (inch water column)	<not with I.4.1-6/-7>	
-18	%rF Relative humidity	<not with I.4.1-6/-7>	
-19	kg/m³ Density	<not with I.4.1-6/-7>	
-20	pH pH	<not with I.4.1-6/-7>	
I.4.4	Input signal increase/decrease	I.4.4-0	
-0	Off		
-1	On		
AI4.COR	Correction value <I.4.4-1>	[-999.0...9999.0]	0.0
I.4.5	Signal monitoring	I.4.5-0	
-0	Off		
-1	On		
-2	On (with default value)		
AI4.K1	Default value <I.4.5-2> · Initial value <I.4.1-5>	[-999.0...9999.0]	0.0
AI4.TOUT	Timeout interface<I.4.1-5, I.4.5≠0>	[1...99999 s]	60 s

I.4	Analog input AI4	Default setting	Setting
I.4.6	Manual mode Controller [1] upon signal failure <I.4.5≠0>	I.4.6-0	
-0	Off		
-1	Constant output value at AO1 <O.1.1-1>		
-2	Constant output value at AO2 <O.2.1-1>		
-3	Constant output value at AO3 <O.3.1-1>		
-4	Constant output value at AO1 <O.4.1-1>		
-5	Constant output value at SO2 <O.5.1-1>		
-6	With last output value <O.1.1-1/O.2.1-1/O.3.1-1/ O.4.1-1/O.5.1-1>		
AO1.K1	Constant output value at AO1 <I.4.6-1> [-10.0 ... 110.0 %]	0.0 %	
AO2.K1	Constant output value at AO2 <I.4.6-2> [-10.0 ... 110.0 %]	0.0 %	
AO3.K1	Constant output value at AO3 <I.4.6-3> [-10.0 ... 110.0 %]	0.0 %	
SO1.K1	Constant output value at SO1 <I.4.6-4> [-10.0 ... 110.0 %]	0.0 %	
SO2.K1	Constant output value at SO2 <I.4.6-5> [-10.0 ... 110.0 %]	0.0 %	
I.4.7	Manual mode Controller [2] upon signal failure <M.1-5/-6, I.4.5≠0>	I.4.7-0	
-0	Off		
-1	Constant output value at AO1 <O.1.1-2>		
-2	Constant output value at AO2 <O.2.1-2>		
-3	Constant output value at AO3 <O.3.1-2>		
-4	Constant output value at AO1 <O.4.1-2>		
-5	Constant output value at SO2 <O.5.1-2>		
-6	With last output value <O.1.1-2/O.2.1-2/O.3.1-2/ O.4.1-2/O.5.1-2>		
AO1.K1	Constant output value at AO1 <I.4.7-1> [-10.0 ... 110.0 %]	0.0 %	
AO2.K1	Constant output value at AO2 <I.4.7-2> [-10.0 ... 110.0 %]	0.0 %	
AO3.K1	Constant output value at AO3 <I.4.7-3> [-10.0 ... 110.0 %]	0.0 %	
SO1.K1	Constant output value at SO1 <I.4.7-4> [-10.0 ... 110.0 %]	0.0 %	
SO2.K1	Constant output value at SO2 <I.4.7-5> [-10.0 ... 110.0 %]	0.0 %	
I.5	Digital input DI1	Default setting	Setting
I.5.1	Invert	I.5.1-0	
-0	Off		
-1	On		

Annex A (configuration guide)

I.6	Digital input DI2	Default setting	Setting
I.6.1	Invert	I.6.1-0	
-0	Off		
-1	On		
I.7	Digital input DI3	Default setting	Setting
I.7.1	Invert	I.7.1-0	
-0	Off		
-1	On		
I.8	Digital input DI4	Default setting	Setting
I.8.1	Invert	I.8.1-0	
-0	Off		
-1	On		

C Controller

i Note

Controller [2] can only be selected with M.1-3/-4/-5/-6.

C.1 Input variables

Con- troller	C.1.1	Input variable PV	Default setting	Setting		
				[1]	[2]	
[1] [2]	C.1.1.1	Assign source	C.1.1.1-1			
		-0				Off
		-1				Analog input AI1
		-2				Analog input AI2
		-3				Analog input AI3
-4	Analog input AI4					
[1] [2]	C.1.1.2	Filter <C.1.1.1≠0>	C.1.1.2-0			
		-0				Off
		-1				On
[1] [2]	PV.T	Time constant <C.1.1.2-1> [0.1 ... 100.0 s]	1.0 s			
[1] [2]	C.1.1.3	Root extraction <C.1.1.1≠0>	C.1.1.3-0			
		-0				Off
		-1				On

Con- troller		C.1.1	Input variable PV	Default setting	Setting [1] [2]	
		C.1.1.4	Function generation <C.1.1.1≠0>	C.1.1.4-0		
[1]	[2]	-0	Off			
[1]	[2]	-1	On			
[1]	[2]	PV.MIN	Lower range value output function generation <C.1.1.4-1> [-999.0 ... 9999.0]	0.0		
[1]	[2]	PV.MAX	Upper range value output function generation <C.1.1.4-1> [-999.0 ... 9999.0]	100.0		
[1]	[2]	PV.I1	Input value 1 <C.1.1.4-1> [-999.0 ... 9999.0]	0.0		
[1]	[2]	PV.O1	Output value 1 <C.1.1.4-1> [-999.0 ... 9999.0]	0.0		
[1]	[2]	PV.I2	Input value 2 <C.1.1.4-1> [-999.0 ... 9999.0]	0.0		
[1]	[2]	PV.O2	Output value 2 <C.1.1.4-1> [-999.0 ... 9999.0]	0.0		
[1]	[2]	PV.I3	Input value 3 <C.1.1.4-1> [-999.0 ... 9999.0]	0.0		
[1]	[2]	PV.O3	Output value 3 <C.1.1.4-1> [-999.0 ... 9999.0]	0.0		
[1]	[2]	PV.I4	Input value 4 <C.1.1.4-1> [-999.0 ... 9999.0]	0.0		
[1]	[2]	PV.O4	Output value 4 <C.1.1.4-1> [-999.0 ... 9999.0]	0.0		
[1]	[2]	PV.I5	Input value 5 <C.1.1.4-1> [-999.0 ... 9999.0]	0.0		
[1]	[2]	PV.O5	Output value 5 <C.1.1.4-1> [-999.0 ... 9999.0]	0.0		
[1]	[2]	PV.I6	Input value 6 <C.1.1.4-1> [-999.0 ... 9999.0]	0.0		
[1]	[2]	PV.O6	Output value 6 <C.1.1.4-1> [-999.0 ... 9999.0]	0.0		
[1]	[2]	PV.I7	Input value 7 <C.1.1.4-1> [-999.0 ... 9999.0]	100.0		
[1]	[2]	PV.O7	Output value 7 <C.1.1.4-1> [-999.0 ... 9999.0]	100.0		
		C.1.1.5	Physical unit after function generation <C.1.1.4-1>	C.1.1.5-0		
[1]	[2]	-0	Off			
[1]	[2]	-1	°C Temperature			
[1]	[2]	-2	°F Temperature			
[1]	[2]	-3	K Temperature			
[1]	[2]	-4	bar Pressure			
[1]	[2]	-5	mbar Pressure			
[1]	[2]	-6	psi Pressure			
[1]	[2]	-7	kPa Pressure			
[1]	[2]	-8	m³/h Flow rate			
[1]	[2]	-9	l/h Flow rate			
[1]	[2]	-10	ft³/h Flow rate			
[1]	[2]	-11	kg/h Mass flow			
[1]	[2]	-12	t/h Mass flow			
[1]	[2]	-13	lb/h Mass flow			
[1]	[2]	-14	%			

Annex A (configuration guide)

Con- troller		C.1.1	Input variable PV		Default setting	Setting [1] [2]	
[1]	[2]	-15	mFS	Filling level			
[1]	[2]	-16	mmFS	Filling level			
[1]	[2]	-17	inH ₂ O	Filling level (inch water column)			
[1]	[2]	-18	%rF	Relative humidity			
[1]	[2]	-19	kg/m ³	Density			
[1]	[2]	-20	pH	pH			

Con- troller		C.1.2	Input variable SPE		Default setting	Setting [1] [2]	
		C.1.2.1	Assign source		C.1.2.1-0		
[1]	[2]	-0	Off				
[1]	[2]	-1	Analog input AI1				
[1]	[2]	-2	Analog input AI2				
[1]	[2]	-3	Analog input AI3				
[1]	[2]	-4	Analog input AI4				
		C.1.2.2	Filter <C.1.2.1≠0>		C.1.2.2-0		
[1]	[2]	-0	Off				
[1]	[2]	-1	On				
[1]	[2]	SPE.T	Time constant <C.1.2.2-1>	[0.1 ... 100.0 s]	1.0 s		
		C.1.2.3	Root extraction <C.1.2.1≠0>		C.1.2.3-0		
[1]	[2]	-0	Off				
[1]	[2]	-1	On				
		C.1.2.4	Function generation <C.1.2.1≠0>		C.1.2.4-0		
[1]	[2]	-0	Off				
[1]	[2]	-1	On				
[1]	[2]	SPE.MIN	Lower range value output function generation <C.1.2.4-1>	[-999.0 ... 9999.0]	0.0		
[1]	[2]	SPE.MAX	Upper range value output function generation <C.1.2.4-1>	[-999.0 ... 9999.0]	100.0		
[1]	[2]	SPE.I1	Input value 1 <C.1.2.4-1>	[-999.0 ... 9999.0]	0.0		
[1]	[2]	SPE.O1	Output value 1 <C.1.2.4-1>	[-999.0 ... 9999.0]	0.0		
[1]	[2]	SPE.I2	Input value 2 <C.1.2.4-1>	[-999.0 ... 9999.0]	0.0		
[1]	[2]	SPE.O2	Output value 2 <C.1.2.4-1>	[-999.0 ... 9999.0]	0.0		
[1]	[2]	SPE.I3	Input value 3 <C.1.2.4-1>	[-999.0 ... 9999.0]	0.0		
[1]	[2]	SPE.O3	Output value 3 <C.1.2.4-1>	[-999.0 ... 9999.0]	0.0		
[1]	[2]	SPE.I4	Input value 4 <C.1.2.4-1>	[-999.0 ... 9999.0]	0.0		
[1]	[2]	SPE.O4	Output value 4 <C.1.2.4-1>	[-999.0 ... 9999.0]	0.0		
[1]	[2]	SPE.I5	Input value 5 <C.1.2.4-1>	[-999.0 ... 9999.0]	0.0		

Con- troller	C.1.2	Input variable SPE	Default setting	Setting		
				[1]	[2]	
[1]	[2]	SPE.O5	Output value 5 <C.1.2.4-1> [-999.0 ... 9999.0]	0.0		
[1]	[2]	SPE.I6	Input value 6 <C.1.2.4-1> [-999.0 ... 9999.0]	0.0		
[1]	[2]	SPE.O6	Output value 6 <C.1.2.4-1> [-999.0 ... 9999.0]	0.0		
[1]	[2]	SPE.I7	Input value 7 <C.1.2.4-1> [-999.0 ... 9999.0]	100.0		
[1]	[2]	SPE.O7	Output value 7 <C.1.2.4-1> [-999.0 ... 9999.0]	100.0		
		C.1.2.5	Physical unit after function generation <C.1.2.4-1>	C.1.2.5-0		
[1]	[2]	-0	Off			
[1]	[2]	-1	°C Temperature			
[1]	[2]	-2	°F Temperature			
[1]	[2]	-3	K Temperature			
[1]	[2]	-4	bar Pressure			
[1]	[2]	-5	mbar Pressure			
[1]	[2]	-6	psi Pressure			
[1]	[2]	-7	kPa Pressure			
[1]	[2]	-8	m ³ /h Flow rate			
[1]	[2]	-9	l/h Flow rate			
[1]	[2]	-10	ft ³ /h Flow rate			
[1]	[2]	-11	kg/h Mass flow			
[1]	[2]	-12	t/h Mass flow			
[1]	[2]	-13	lb/h Mass flow			
[1]	[2]	-14	%			
[1]	[2]	-15	mFS Filling level			
[1]	[2]	-16	mmFS Filling level			
[1]	[2]	-17	inH ₂ O Filling level (inch water column)			
[1]	[2]	-18	%rF Relative humidity			
[1]	[2]	-19	kg/m ³ Density			
[1]	[2]	-20	pH pH			
Con- troller	C.1.3	Input variable DV	Default setting	Setting		
				[1]	[2]	
		C.1.3.1	Assign source	C.1.3.1-0		
[1]	[2]	-0	Off			
[1]	[2]	-1	Analog input AI1			
[1]	[2]	-2	Analog input AI2			
[1]	[2]	-3	Analog input AI3			
[1]	[2]	-4	Analog input AI4			

Annex A (configuration guide)

Con- troller		C.1.3	Input variable DV	Default setting	Setting [1] [2]	
[1]	[2]	C.1.3.2	Filter <C.1.3.1≠0>	C.1.3.2-0		
[1]	[2]		-0 Off			
[1]	[2]		-1 On			
[1]	[2]	DV.T	Time constant <C.1.3.2-1> [0.1 ... 100.0 s]	1.0 s		
[1]	[2]	C.1.3.3	Root extraction <C.1.3.1≠0>	C.1.3.3-0		
[1]	[2]		-0 Off			
[1]	[2]		-1 On			
[1]	[2]	C.1.3.4	Function generation <C.1.3.1≠0>	C.1.3.4-0		
[1]	[2]		-0 Off			
[1]	[2]		-1 On			
[1]	[2]	DV.MIN	Lower range value output function generation <C.1.3.4-1> [-999.0 ... 9999.0]	0.0		
[1]	[2]	DV.MAX	Upper range value output function generation <C.1.3.4-1> [-999.0 ... 9999.0]	100.0		
[1]	[2]	DV.I1	Input value 1 <C.1.3.4-1> [-999.0 ... 9999.0]	0.0		
[1]	[2]	DV.O1	Output value 1 <C.1.3.4-1> [-999.0 ... 9999.0]	0.0		
[1]	[2]	DV.I2	Input value 2 <C.1.3.4-1> [-999.0 ... 9999.0]	0.0		
[1]	[2]	DV.O2	Output value 2 <C.1.3.4-1> [-999.0 ... 9999.0]	0.0		
[1]	[2]	DV.I3	Input value 3 <C.1.3.4-1> [-999.0 ... 9999.0]	0.0		
[1]	[2]	DV.O3	Output value 3 <C.1.3.4-1> [-999.0 ... 9999.0]	0.0		
[1]	[2]	DV.I4	Input value 4 <C.1.3.4-1> [-999.0 ... 9999.0]	0.0		
[1]	[2]	DV.O4	Output value 4 <C.1.3.4-1> [-999.0 ... 9999.0]	0.0		
[1]	[2]	DV.I5	Input value 5 <C.1.3.4-1> [-999.0 ... 9999.0]	0.0		
[1]	[2]	DV.O5	Output value 5 <C.1.3.4-1> [-999.0 ... 9999.0]	0.0		
[1]	[2]	DV.I6	Input value 6 <C.1.3.4-1> [-999.0 ... 9999.0]	0.0		
[1]	[2]	DV.O6	Output value 6 <C.1.3.4-1> [-999.0 ... 9999.0]	0.0		
[1]	[2]	DV.I7	Input value 7 <C.1.3.4-1> [-999.0 ... 9999.0]	100.0		
[1]	[2]	DV.O7	Output value 7 <C.1.3.4-1> [-999.0 ... 9999.0]	100.0		
[1]	[2]	C.1.3.5	Physical unit after function generation <C.1.3.4-1>	C.1.3.5-0		
[1]	[2]		-0 Off			
[1]	[2]		-1 °C Temperature			
[1]	[2]		-2 °F Temperature			
[1]	[2]		-3 K Temperature			
[1]	[2]		-4 bar Pressure			
[1]	[2]		-5 mbar Pressure			
[1]	[2]		-6 psi Pressure			
[1]	[2]	-7 kPa Pressure				

Con- troller	C.1.3	Input variable DV	Default setting	Setting	
				[1]	[2]
[1] [2]	-8	m ³ /h Flow rate			
[1] [2]	-9	l/h Flow rate			
[1] [2]	-10	ft ³ /h Flow rate			
[1] [2]	-11	kg/h Mass flow			
[1] [2]	-12	t/h Mass flow			
[1] [2]	-13	lb/h Mass flow			
[1] [2]	-14	%			
[1] [2]	-15	mFS Filling level			
[1] [2]	-16	mmFS Filling level			
[1] [2]	-17	inH ₂ O Filling level (inch water column)			
[1] [2]	-18	%rF Relative humidity			
[1] [2]	-19	kg/m ³ Density			
[1] [2]	-20	pH pH			

Con- troller	C.1.4	Input variable TR	Default setting	Setting	
				[1]	[2]
	C.1.4.1	Assign source	C.1.4.1-0		
[1] [2]	-0	Off			
[1] [2]	-1	Analog input AI1			
[1] [2]	-2	Analog input AI2			
[1] [2]	-3	Analog input AI3			
[1] [2]	-4	Analog input AI4			
	C.1.4.2	Filter <C.1.4.1≠0>	C.1.4.2-0		
[1] [2]	-0	Off			
[1] [2]	-1	On			
[1] [2]	TR.T	Time constant <C.1.4.2-1> [0.1 ... 100.0 s]	1.0 s		
	C.1.4.3	Root extraction <C.1.4.1≠0>	C.1.4.3-0		
[1] [2]	-0	Off			
[1] [2]	-1	On			
	C.1.4.4	Function generation <C.1.4.1≠0>	C.1.4.4-0		
[1] [2]	-0	Off			
[1] [2]	-1	On			
[1] [2]	TR.MIN	Lower range value output function generation <C.1.4.4-1> [-999.0 ... 9999.0]	0.0		
[1] [2]	TR.MAX	Upper range value output function generation <C.1.4.4-1> [-999.0 ... 9999.0]	100.0		
[1] [2]	TR.I1	Input value 1 <C.1.4.4-1> [-999.0 ... 9999.0]	0.0		
[1] [2]	TR.O1	Output value 1 <C.1.4.4-1> [-999.0 ... 9999.0]	0.0		

Annex A (configuration guide)

Con- troller	C.1.4	Input variable TR	Default setting	Setting		
				[1]	[2]	
[1]	[2]	TR.I2	Input value 2 <C.1.4.4-1> [-999.0 ... 9999.0]	0.0		
[1]	[2]	TR.O2	Output value 2 <C.1.4.4-1> [-999.0 ... 9999.0]	0.0		
[1]	[2]	TR.I3	Input value 3 <C.1.4.4-1> [-999.0 ... 9999.0]	0.0		
[1]	[2]	TR.O3	Output value 3 <C.1.4.4-1> [-999.0 ... 9999.0]	0.0		
[1]	[2]	TR.I4	Input value 4 <C.1.4.4-1> [-999.0 ... 9999.0]	0.0		
[1]	[2]	TR.O4	Output value 4 <C.1.4.4-1> [-999.0 ... 9999.0]	0.0		
[1]	[2]	TR.I5	Input value 5 <C.1.4.4-1> [-999.0 ... 9999.0]	0.0		
[1]	[2]	TR.O5	Output value 5 <C.1.4.4-1> [-999.0 ... 9999.0]	0.0		
[1]	[2]	TR.I6	Input value 6 <C.1.4.4-1> [-999.0 ... 9999.0]	0.0		
[1]	[2]	TR.O6	Output value 6 <C.1.4.4-1> [-999.0 ... 9999.0]	0.0		
[1]	[2]	TR.I7	Input value 7 <C.1.4.4-1> [-999.0 ... 9999.0]	100.0		
[1]	[2]	TR.O7	Output value 7 <C.1.4.4-1> [-999.0 ... 9999.0]	100.0		
		C.1.4.5	Physical unit after function generation <C.1.4.4-1>	C.1.4.5-0		
[1]	[2]	-0	Off			
[1]	[2]	-1	°C Temperature			
[1]	[2]	-2	°F Temperature			
[1]	[2]	-3	K Temperature			
[1]	[2]	-4	bar Pressure			
[1]	[2]	-5	mbar Pressure			
[1]	[2]	-6	psi Pressure			
[1]	[2]	-7	kPa Pressure			
[1]	[2]	-8	m ³ /h Flow rate			
[1]	[2]	-9	l/h Flow rate			
[1]	[2]	-10	ft ³ /h Flow rate			
[1]	[2]	-11	kg/h Mass flow			
[1]	[2]	-12	t/h Mass flow			
[1]	[2]	-13	lb/h Mass flow			
[1]	[2]	-14	%			
[1]	[2]	-15	mFS Filling level			
[1]	[2]	-16	mmFS Filling level			
[1]	[2]	-17	inH ₂ O Filling level (inch water column)			
[1]	[2]	-18	%rF Relative humidity			
[1]	[2]	-19	kg/m ³ Density			
[1]	[2]	-20	pH pH			

Con- troller		C.1.5	Input variable FB	Default setting	Setting [1] [2]	
[1]	[2]	C.1.5.1	Assign source	C.1.5.1-0		
[1]	[2]	-0	Off			
[1]	[2]	-1	Analog input AI1			
[1]	[2]	-2	Analog input AI2			
[1]	[2]	-3	Analog input AI3			
[1]	[2]	-4	Analog input AI4			
[1]	[2]	C.1.5.2	Filter <C.1.5.1≠0>	C.1.5.2-0		
[1]	[2]	-0	Off			
[1]	[2]	-1	On			
[1]	[2]	FB.T	Time constant <C.1.5.2-1>	[0.1 ... 100.0 s]	1.0 s	

C.2 Set point

Con- troller		C.2.1	Set point adjustment	Default setting	Setting [1] [2]	
[1]	[2]	C.2.1.1	Number of internal set points	C.2.1.1-1		
[1]	[2]	-1	1			
[1]	[2]	-2	2			
[1]	[2]	-3	3			
[1]	[2]	-4	4			
[1]	[2]	SP1	Set point [1]<M.1-2/-6>:	[-999.0 ... 9999.0] [0.0 ... 9999.0]	0.0	
[1]	[2]	SP1.MIN	Lower adjustment limit [1]<M.1-2/-6>:	[-999.0 ... 9999.0] [0.0 ... 9999.0]	0.0	
[1]	[2]	SP1.MAX	Upper adjustment limit [1]<M.1-2/-6>:	[-999.0 ... 9999.0] [0.0 ... 9999.0]	100.0	
[1]	[2]	SP2	Set point <C.2.1.1-2/-3/-4> [1]<M.1-2/-6>:	[-999.0 ... 9999.0] [0.0 ... 9999.0]	0.0	
[1]	[2]	SP2.MIN	Lower adjustment limit <C.2.1.1≠1> [1]<M.1-2/-6>:	[-999.0 ... 9999.0] [0.0 ... 9999.0]	0.0	
[1]	[2]	SP2.MAX	Upper adjustment limit <C.2.1.1≠1> [1]<M.1-2/-6>:	[-999.0 ... 9999.0] [0.0 ... 9999.0]	100.0	
[1]	[2]	SP3	Set point <C.2.1.1-3/-4> [1]<M.1-2/-6>:	[-999.0 ... 9999.0] [0.0 ... 9999.0]	0.0	
[1]	[2]	SP3.MIN	Lower adjustment limit <C.2.1.1-3/-4> [1]<M.1-2/-6>:	[-999.0 ... 9999.0] [0.0 ... 9999.0]	0.0	

Annex A (configuration guide)

Con- troller	C.2.1	Set point adjustment	Default setting	Setting	
				[1]	[2]
[1]	[2]	SP3.MAX Upper adjustment limit <C.2.1.1-3/-4> [-999.0 ... 9999.0] [1]<M.1-2/-6>: [0.0 ... 9999.0]	100.0		
[1]	[2]	SP4 Set point <C.2.1.1-4> [-999.0 ... 9999.0] [1]<M.1-2/-6>: [0.0 ... 9999.0]	0.0		
[1]	[2]	SP4.MIN Lower adjustment limit <C.2.1.1-4> [-999.0 ... 9999.0] [1]<M.1-2/-6>: [0.0 ... 9999.0]	0.0		
[1]	[2]	SP4.MAX Upper adjustment limit <C.2.1.1-4> [-999.0 ... 9999.0] [1]<M.1-2/-6>: [0.0 ... 9999.0]	100.0		
		C.2.1.2 External set point	C.2.1.2-0		
[1]	[2]	-0 Off			
[1]	[2]	-1 Via input variable SPE <C.1.2.1≠0>			
[1]	[2]	-2 Via interface SPC; only with M.1-3 Controller [2]			
[1]		SPC.K1 Initial value <C.2.1.2-2> [-999.0 ... 9999.0] Default value <C.2.1.6-2>	0.0		
		C.2.1.3 Ratio formula <M.1-2/-6>	C.2.1.3-1		
[1]		-1 (PV/DV)*K11			
[1]		-2 (PV/(PV+DV*K13))*K11			
[1]		-3 ((PV+DV*K13)/PV)*K11			
[1]		-4 Universal formula $\frac{(PV*K12+DV*K13+TR*K14)}{(PV*K22+DV*K23+TR*K24)} * K11$			
[1]		K11 Factor [0.0 ... 9999.0]	1.0		
[1]		K12 Factor for PV <C.2.1.3-4> [-999.0 ... 9999.0]	1.00		
[1]		K13 Factor for DV <C.2.1.3≠1> [-999.0 ... 9999.0]	1.00		
[1]		K14 Factor for TR <C.2.1.3-4> [-999.0 ... 9999.0]	1.00		
[1]		K22 Factor for PV <C.2.1.3-4> [-999.0 ... 9999.0]	1.00		
[1]		K23 Factor for DV <C.2.1.3-4> [-999.0 ... 9999.0]	0.00		
[1]		K24 Factor for TR <C.2.1.3-4> [-999.0 ... 9999.0]	0.00		
		C.2.1.4 Decimal point for set points	C.2.1.4-1		
[1]	[2]	-0 XXXX No decimal place			
[1]	[2]	-1 XXX.X 1 decimal place			
[1]	[2]	-2 XX.XX 2 decimal places			
[1]	[2]	-3 X.XXX 3 decimal places			

Con- troller		C.2.1	Set point adjustment	Default setting	Setting [1] [2]	
		C.2.1.5	Physical unit for set points	C.2.1.5-1		
[1]	[2]	-0	Off	The unit is already set depending on PV. Ratio controller: C.2.1.5-0		
[1]	[2]	-1	°C Temperature			
[1]	[2]	-2	°F Temperature			
[1]	[2]	-3	K Temperature			
[1]	[2]	-4	bar Pressure			
[1]	[2]	-5	mbar Pressure			
[1]	[2]	-6	psi Pressure			
[1]	[2]	-7	kPa Pressure			
[1]	[2]	-8	m ³ /h Flow rate			
[1]	[2]	-9	l/h Flow rate			
[1]	[2]	-10	ft ³ /h Flow rate			
[1]	[2]	-11	kg/h Mass flow			
[1]	[2]	-12	t/h Mass flow			
[1]	[2]	-13	lb/h Mass flow			
[1]	[2]	-14	%			
[1]	[2]	-15	mFS Filling level			
[1]	[2]	-16	mmFS Filling level			
[1]	[2]	-17	inH ₂ O Filling level (inch water column)			
[1]	[2]	-18	%rF Relative humidity			
[1]	[2]	-19	kg/m ³ Density			
[1]	[2]	-20	pH pH			
		C.2.1.6	Signal monitoring SPC <C.2.1.2-2>	C.2.1.6-0		
[1]	[2]	-0	Off			
[1]	[2]	-1	On			
[1]	[2]	-2	On (with default value)			
[1]	[2]	SPC.K1	Default value <C.2.1.6-1/-2> [-999.0 ... 9999.0] Initial value <C.2.1.2-2>	0.0		
[1]	[2]	SPC.TOUT	Timeout interface <C.2.1.6-1/-2> [1 ... 99999 s]	60 s		
		C.2.1.7	Manual mode controller at signal error SPC <C.2.1.6≠0>	C.2.1.7-0		
[1]	[2]	-0	Off			
[1]		-1	Constant output value at AO1 <O.1.1-1/-38/-39>			
[1]		-2	Constant output value at AO2 <O.1.2-1/-38/-39>			
[1]		-3	Constant output value at AO3 <O.1.3-1/-38/-39>			
[1]		-4	Constant output value at SO1 <O.1.4-1/-38/-39>			

Annex A (configuration guide)

Con- troller	C.2.1	Set point adjustment	Default setting	Setting	
				[1]	[2]
[1]		-5 Constant output value at SO2 <O.1.5-1/-38/-39>			
[1]		-6 With last output value <O.1.1-1/-38/-39/O.2.1-1/-38/-39/O.3.1-1/-38/-39/ O.4.1-1/-38/-39/O.5.1-1/-38/-39>			
	[2]	-1 Constant output value at AO1 <O.1.1-2/-38/-39>			
	[2]	-2 Constant output value at AO2 <O.1.2-2/-38/-39>			
	[2]	-3 Constant output value at AO3 <O.1.3-2/-38/-39>			
	[2]	-4 Constant output value at SO1 <O.1.4-2/-38/-39>			
	[2]	-5 Constant output value at SO2 <O.1.5-2/-38/-39>			
	[2]	-6 With last output value <O.1.1-2/-38/-39/O.2.1-2/-38/-39/O.3.1-2/-38/-39/ O.4.1-2/-38/-39/O.5.1-2/-38/-39>			
[1]	[2]	AO1.K1 Constant output value at AO1 <C.2.1.7-1> [-10.0 ... 110.0 %]	0.0 %		
[1]	[2]	AO2.K1 Constant output value at AO2 <C.2.1.7-2> [-10.0 ... 110.0 %]	0.0 %		
[1]	[2]	AO3.K1 Constant output value at AO3 <C.2.1.7-3> [-10.0 ... 110.0 %]	0.0 %		
[1]	[2]	SO1.K1 Constant output value at AO1 <C.2.1.7-4> [-10.0 ... 110.0 %]	0.0 %		
[1]	[2]	SO2.K1 Constant output value at SO2 <C.2.1.7-5> [-10.0 ... 110.0 %]	0.0 %		

Con- troller	C.2.2	Set point switchover	Default setting	Setting	
				[1]	[2]
	C.2.2.1	Changeover internal set points with DI	C.2.2.1-0		
[1]	[2]	-0 Off			
[1]	[2]	-1 SP1/SP2 with DI1 <C.2.1.1-2>			
[1]	[2]	-2 SP1/SP2 with DI2 <C.2.1.1-2>			
[1]	[2]	-3 SP1/SP2 with DI3 <C.2.1.1-2>			
[1]	[2]	-4 SP1/SP2 with DI4 <C.2.1.1-2>			
[1]	[2]	-5 SP1...SP4 with DI1, DI2 <C.2.1.1-4>			
[1]	[2]	-6 SP1...SP4 with DI3, DI4 <C.2.1.1-4>			
[1]	[2]	-7 SP1...SP3 with DI2, DI3 <C.2.1.1-3>			
[1]	[2]	-8 SP1...SP4 with DI2, 3, 4 <C.2.1.1-4>			

Con- troller		C.2.2	Set point switchover	Default setting	Setting [1] [2]	
[1]	[2]	C.2.2.2	Changeover to external set point with DI <C.2.1.2≠0>; M.1-3: Controller [2] only	C.2.2.2-0		
		-0	Off			
[1]	[2]	-1	With digital input DI1			
[1]	[2]	-2	With digital input DI2			
[1]	[2]	-3	With digital input DI3			
[1]	[2]	-4	With digital input DI4			
[1]		C.2.2.3	Open cascade with DI <M.1-3>	C.2.2.3-0		
		-0	Off			
[1]		-1	With digital input DI1			
[1]		-2	With digital input DI2			
[1]		-3	With digital input DI3			
[1]		-4	With digital input DI4			
[1]	[2]	C.2.2.4	Tracking SPI to SPE/SPC <C.2.1.2≠0>	C.2.2.4-0		
		-0	Off			
[1]	[2]	-1	On			
[1]	[2]	C.2.2.5	Incremental/decremental set point change <M.1-3>	C.2.2.5-0		
		-0	Off			
[1]	[2]	-1	With digital input DI1, 2			
[1]	[2]	-2	With digital input DI3, 4			
[1]	[2]	K10.A	Incremental value [-999.0 ... 9999.0] <C.2.2.4≠0>	0.0		
[1]	[2]	K10.B	Decremental value [-999.0 ... 9999.0] <C.2.2.4≠0>	0.0		
[1]	[2]	C.2.2.6	Set point increase/decrease by constant	C.2.2.6-0		
		-0	Off			
[1]	[2]	-1	With digital input DI1			
[1]	[2]	-2	With digital input DI2			
[1]	[2]	-3	With digital input DI3			
[1]	[2]	-4	With digital input DI4			
[1]	[2]	K10	Incremental/decremental value <C.2.2.6≠0> [-999.0 ... 9999.0]	0.0		

Annex A (configuration guide)

Con- troller		C.2.3	Set point ramp function	Default setting	Setting [1] [2]	
		C.2.3.1	Set point ramp	C.2.3.1-0		
[1]	[2]	-0	Off			
[1]	[2]	-1	Start with DI1, SP=Pv			
[1]	[2]	-2	Start with DI2, SP=Pv			
[1]	[2]	-3	Start with DI3, SP=Pv			
[1]	[2]	-4	Start with DI4, SP=Pv			
[1]	[2]	-5	Start with DI1, SP=SP.ST			
[1]	[2]	-6	Start with DI2, SP=SP.ST			
[1]	[2]	-7	Start with DI3, SP=SP.ST			
[1]	[2]	-8	Start with DI4, SP=SP.ST			
[1]	[2]	-9	Continuously active			
[1]	[2]	SP.GD	Gradient <C.2.3.1≠0> [0.0 ... 9999.0]	1.0		
[1]	[2]	SP.TB	Time base <C.2.3.1≠0> [s, min, h]	s		
[1]	[2]	SP.ST	Initial set point <C.2.3.1-5/-6/-7/-8> [-999.0 ... 9999.0]	0.0		
[1]	[2]	SP.RH	Hold set point ramp at deviation band <C.2.3.1≠0> [0.1 ... 1000.0 %] Firmware version 1.11 and lower: [0.1 ... 100.0 %]	1000.0 % 100.0 %		
		C.2.3.2	Hold set point ramp with DI <C.2.3.1≠0>	C.2.3.2-0		
[1]	[2]	-0	Off			
[1]	[2]	-1	With digital input DI1			
[1]	[2]	-2	With digital input DI2			
[1]	[2]	-3	With digital input DI3			
[1]	[2]	-4	With digital input DI4			

Con- troller		C.2.4	Additional set point functions	Default setting	Setting [1] [2]	
		C.2.4.1	Valuate external set point SPE <C.2.1.2≠0>	C.2.3.2-0		
[1]	[2]	-0	Off			
[1]	[2]	-1	On			
[1]	[2]	K1	Valuation: $SPE' = SPE \cdot K1 + K2$ <C.2.4.1-1> [-100.00 ... 100.00]	1.00		
[1]	[2]	K2	Valuation: $SPE' = SPE \cdot K1 + K2$ <C.2.4.1-1> [-9999.0 ... 9999.0]	0.0		

Con- troller		C.2.4	Additional set point functions	Default setting	Setting [1] [2]	
[1]	[2]	C.2.4.2	Linking up external/internal set point <C.2.1.2≠0>	C.2.4.2-0		
[1]	[2]		-0 Off			
[1]	[2]		-1 Min. selection (SPI, SPE)			
[1]	[2]		-2 Max. selection (SPI, SPE)			
[1]	[2]		-3 SPI + SPE			
[1]	[2]		-4 SPI – SPE			
[1]	[2]	-5 SPE – SPI				
[1]		C.2.4.3	Function generation set point SPM at slave con- troller <M.1-3>	C.2.4.3-0		
[1]			-0 Off			
[1]		-1 On				
[1]		SPM.I1	Input value 1 <C.2.4.3-1> [0.0 ... 100.0 %]	0.0 %		
[1]		SPM.O1	Output value 1 <C.2.4.3-1> [-999.0 ... 9999.0]	0.0		
[1]		SPM.I2	Input value 2 <C.2.4.3-1> [0.0 ... 100.0 %]	0.0 %		
[1]		SPM.O2	Output value 2 <C.2.4.3-1> [-999.0 ... 9999.0]	0.0		
[1]		SPM.I3	Input value 3 <C.2.4.3-1> [0.0 ... 100.0 %]	0.0 %		
[1]		SPM.O3	Output value 3 <C.2.4.3-1> [-999.0 ... 9999.0]	0.0		
[1]		SPM.I4	Input value 4 <C.2.4.3-1> [0.0 ... 100.0 %]	0.0 %		
[1]		SPM.O4	Output value 4 <C.2.4.3-1> [-999.0 ... 9999.0]	0.0		
[1]		SPM.I5	Input value 5 <C.2.4.3-1> [0.0 ... 100.0 %]	0.0 %		
[1]		SPM.O5	Output value 5 <C.2.4.3-1> [-999.0 ... 9999.0]	0.0		
[1]		SPM.I6	Input value 6 <C.2.4.3-1> [0.0 ... 100.0 %]	0.0 %		
[1]		SPM.O6	Output value 6 <C.2.4.3-1> [-999.0 ... 9999.0]	0.0		
[1]		SPM.I7	Input value 7 <C.2.4.3-1> [0.0 ... 100.0 %]	0.0 %		
[1]		SPM.O7	Output value 7 <C.2.4.3-1> [-999.0 ... 9999.0]	100.0		

C.3 Control function

Con- troller		C.3.1	Control response	Default setting	Setting [1] [2]	
[1]	[2]	C.3.1.1	Control algorithm	C.3.1.1-1		
[1]	[2]		-1 PI			
[1]	[2]		-2 P			
[1]	[2]		-3 PD			
[1]	[2]		-4 PID			
[1]	[2]		-5 I			

Annex A (configuration guide)

Con- troller	C.3.1	Control response	Default setting	Setting		
				[1]	[2]	
[1]	[2]	KP	Proportional-action coefficient [0.01 ... 100.0]	1.00		
[1]	[2]	TN	Reset time <C.3.1.1-1/-4/-5> [1 ... 9999 s]	120 s		
[1]	[2]	TV	Derivative-action time <C.3.1.1-3/-4> [1 ... 9999 s]	10 s		
[1]	[2]	Y0	Operating point [-10.0 ... 110.0 %]	0.0 %		
[1]	[2]	TV.K	Derivative-action gain <C.3.1.1-3/-4> [0.00 ... 10.00]	1.00		
		C.3.1.2 Limit I-component <C.3.1.1-1/-4/-5>		C.3.1.2-0		
[1]	[2]	-0	Off			
[1]	[2]	-1	On			
[1]	[2]	I.MIN	Minimum I-component <C.3.1.2-1> [-120.0 ... 0.0 %]	-100.0 %		
[1]	[2]	I.MAX	Maximum I-component <C.3.1.2-1> [0.0 ... 120.0 %]	100.0 %		
		C.3.1.3 Error		C.3.1.3-1		
[1]	[2]	-1	Not inverted			
[1]	[2]	-2	Inverted			
[1]	[2]	-3	Inverted via DI1			
[1]	[2]	-4	Inverted via DI2			
[1]	[2]	-5	Inverted via DI3			
[1]	[2]	-6	Inverted via DI4			
[1]	[2]	E.TZ	Dead band [0.00 ... 110.00 %] Firmware version 1.11 and lower [0.0 ... 110.0 %]			
[1]	[2]	E.MIN	Min. effective error signal [-110.0 ... 110.0 %]			
[1]	[2]	E.MAX	Max. effective error signal [-110.0 ... 110.0 %]			
		C.3.1.4 Assign D-component <C.3.1.1-3/-4>		C.3.1.4-1		
[1]	[2]	-1	To error signal			
[1]	[2]	-2	To controlled variable			
		C.3.1.5 Control mode changeover P(D)/PI(D) <C.3.1.1-1/-4>		C.3.1.5-0		
[1]	[2]	-0	Off			
[1]	[2]	-1	With digital input DI1			
[1]	[2]	-2	With digital input DI2			
[1]	[2]	-3	With digital input DI3			
[1]	[2]	-4	With digital input DI4			
[1]	[2]	-5	By error			
[1]	[2]	E.SMIN	Min. limit for PI(D) behavior <C.3.1.5-5> [-999.0 ... 999.0 %]	-10.0 %		

Con- troller	C.3.1	Control response	Default setting	Setting	
				[1]	[2]
[1] [2]	E.SMAX	Max. limit for PI(D) behavior <C.3.1.5-5> [-999.0 ... 999.0 %]	10.0 %		
[1] [2]	KP.S	Prop.-action coefficient for P(D) behavior <C.3.1.5≠0> [0.01 ... 100.0]	1.00		
	C.3.1.6	Function generation KP	C.3.1.6-0		
[1] [2]	-0	Off			
[1] [2]	-1	With set point SPO			
[1] [2]	-2	With actual value PVO			
[1] [2]	-3	With error signal +/-e			
[1] [2]	-4	With output AO1			
[1] [2]	-5	With output AO2			
[1] [2]	-6	With output AO3			
[1] [2]	-7	With output SO1			
[1] [2]	-8	With output SO2			
[1] [2]	FKP.I1	Input value 1 <C.3.1.6≠0> [-999.0 ... 9999.0]	0.00		
[1] [2]	FKP.O1	Output value 1 <C.3.1.6≠0> [0.01 ... 100.0]	1.00		
[1] [2]	FKP.I2	Input value 2 <C.3.1.6≠0> [-999.0 ... 9999.0]	0.00		
[1] [2]	FKP.O2	Output value 2 <C.3.1.6≠0> [0.01 ... 100.0]	1.00		
[1] [2]	FKP.I3	Input value 3 <C.3.1.6≠0> [-999.0 ... 9999.0]	0.00		
[1] [2]	FKP.O3	Output value 3 <C.3.1.6≠0> [0.01 ... 100.0]	1.00		
[1] [2]	FKP.I4	Input value 4 <C.3.1.6≠0> [-999.0 ... 9999.0]	0.00		
[1] [2]	FKP.O4	Output value 4 <C.3.1.6≠0> [0.01 ... 100.0]	1.00		
[1] [2]	FKP.I5	Input value 5 <C.3.1.6≠0> [-999.0 ... 9999.0]	0.00		
[1] [2]	FKP.O5	Output value 5 <C.3.1.6≠0> [0.01 ... 100.0]	1.00		
[1] [2]	FKP.I6	Input value 6 <C.3.1.6≠0> [-999.0 ... 9999.0]	0.00		
[1] [2]	FKP.O6	Output value 6 <C.3.1.6≠0> [0.01 ... 100.0]	1.00		
[1] [2]	FKP.I7	Input value 7 <C.3.1.6≠0> [-999.0 ... 9999.0]	0.00		
[1] [2]	FKP.O7	Output value 7 <C.3.1.6≠0> [0.01 ... 100.0]	1.00		
	C.3.1.7	Function generation TN <C.3.1.1-1/-4/-5>	C.3.1.7-0		
[1] [2]	-0	Off			
[1] [2]	-1	With set point SPO			
[1] [2]	-2	With actual value PVO			
[1] [2]	-3	With error signal +/-e			
[1] [2]	-4	With output AO1			
[1] [2]	-5	With output AO2			
[1] [2]	-6	With output AO3			
[1] [2]	-7	With output SO1			
[1] [2]	-8	With output SO2			

Annex A (configuration guide)

Con- troller	C.3.1	Control response	Default setting	Setting		
				[1]	[2]	
[1]	[2]	FTN.I1	Input value 1 <C.3.1.7#0> [-999.0 ... 9999.0]	0.00		
[1]	[2]	FTN.O1	Output value 1 <C.3.1.7#0> [0.01 ... 100.0]	1.00		
[1]	[2]	FTN.I2	Input value 2 <C.3.1.7#0> [-999.0 ... 9999.0]	0.00		
[1]	[2]	FTN.O2	Output value 2 <C.3.1.7#0> [0.01 ... 100.0]	1.00		
[1]	[2]	FTN.I3	Input value 3 <C.3.1.7#0> [-999.0 ... 9999.0]	0.00		
[1]	[2]	FTN.O3	Output value 3 <C.3.1.7#0> [0.01 ... 100.0]	1.00		
[1]	[2]	FTN.I4	Input value 4 <C.3.1.7#0> [-999.0 ... 9999.0]	0.00		
[1]	[2]	FTN.O4	Output value 4 <C.3.1.7#0> [0.01 ... 100.0]	1.00		
[1]	[2]	FTN.I5	Input value 5 <C.3.1.7#0> [-999.0 ... 9999.0]	0.00		
[1]	[2]	FTN.O5	Output value 5 <C.3.1.7#0> [0.01 ... 100.0]	1.00		
[1]	[2]	FTN.I6	Input value 6 <C.3.1.7#0> [-999.0 ... 9999.0]	0.00		
[1]	[2]	FTN.O6	Output value 6 <C.3.1.7#0> [0.01 ... 100.0]	1.00		
[1]	[2]	FTN.I7	Input value 7 <C.3.1.7#0> [-999.0 ... 9999.0]	0.00		
[1]	[2]	FTN.O7	Output value 7 <C.3.1.7#0> [0.01 ... 100.0]	1.00		
		C.3.1.8	Set operating point by set point	C.3.1.8-0		
[1]	[2]	-0	Off			
[1]	[2]	-1	On			
[1]	[2]	OP.I1	Input value 1 <C.3.1.6-1> [-999.0 ... 9999.0]	0.0		
[1]	[2]	OP.O1	Output value 1 <C.3.1.6-1> [-10.0 ... 110.0 %]	0.0 %		
[1]	[2]	OP.I2	Input value 2 <C.3.1.6-1> [-999.0 ... 9999.0]	0.0		
[1]	[2]	OP.O2	Output value 2 <C.3.1.6-1> [-10.0 ... 110.0 %]	0.0 %		
[1]	[2]	OP.I3	Input value 3 <C.3.1.6-1> [-999.0 ... 9999.0]	0.0		
[1]	[2]	OP.O3	Output value 3 <C.3.1.6-1> [-10.0 ... 110.0 %]	0.0 %		
[1]	[2]	OP.I4	Input value 4 <C.3.1.6-1> [-999.0 ... 9999.0]	0.0		
[1]	[2]	OP.O4	Output value 4 <C.3.1.6-1> [-10.0 ... 110.0 %]	0.0 %		
[1]	[2]	OP.I5	Input value 5 <C.3.1.6-1> [-999.0 ... 9999.0]	0.0		
[1]	[2]	OP.O5	Output value 5 <C.3.1.6-1> [-10.0 ... 110.0 %]	0.0 %		
[1]	[2]	OP.I6	Input value 6 <C.3.1.6-1> [-999.0 ... 9999.0]	0.0		
[1]	[2]	OP.O6	Output value 6 <C.3.1.6-1> [-10.0 ... 110.0 %]	0.0 %		
[1]	[2]	OP.I7	Input value 7 <C.3.1.6-1> [-999.0 ... 9999.0]	0.0		
[1]	[2]	OP.O7	Output value 7 <C.3.1.6-1> [-10.0 ... 110.0 %]	0.0 %		
		C.3.1.9	Operating point 1 with DI	C.3.1.9-0		
[1]	[2]	-0	Off			
[1]	[2]	-1	With digital input DI1			
[1]	[2]	-2	With digital input DI2			
[1]	[2]	-3	With digital input DI3			
[1]	[2]	-4	With digital input DI4			
[1]	[2]	Y0.1	Operating point 1 <C3.1.9#0> [-110.0 ... 110.0 %]	0.0 %		

Con- troller		C.3.1	Control response	Default setting	Setting [1] [2]	
[1]	[2]	C.3.1.10	Operating point 2 with DI	C.3.1.10-0		
[1]	[2]		-0 Off			
[1]	[2]		-1 With digital input DI1			
[1]	[2]		-2 With digital input DI2			
[1]	[2]		-3 With digital input DI3			
[1]	[2]		-4 With digital input DI4			
[1]	[2]	Y0.2	Operating point 2 [-110.0 ... 110.0 %] <C3.1.10≠0>	0.0 %		
[1]		C.3.1.11	Internally controlled output limitation <M.1-4>	C.3.1.11-1		
[1]			-1 Minimum selection			
[1]		-2 Maximum selection				
[1]		OC.K1	Limiting band master control- ler [0.1 ... 110.0 %]	5.0 %		
[1]		OC.K2	Limiting band override control- ler [0.1 ... 110.0 %]	5.0 %		

Con- troller		C.3.2	Feedforward control	Default setting	Setting [1] [2]	
[1]	[2]	C.3.2.1	Link input variable SPE	C3.2.1-0		
[1]	[2]		-0 Off			
[1]	[2]		-1 To input variable PV			
[1]	[2]	-2 To inputs DV, TR M.1-2/-6 Controller [1]: To input TR				
[1]	[2]	C.3.2.2	Valuate input variable SPE <C.3.2.1≠0>	C.3.2.2-1		
[1]	[2]		-1 Result pos./neg.			
[1]	[2]		-2 Result ≥ 0			
[1]	[2]	-3 Result ≤ 0				
[1]	[2]	K3	Constant, formula: SPE*K3+K4 [-100.00 ... 100.00]	1.00		
[1]	[2]	K4	Constant, formula: SPE*K3+K4 [-9999.0 ... 9999.0]	0.0		
[1]	[2]	C.3.2.3	Link input variables DV, TR	C.3.2.3-0		
[1]	[2]		M.1-2/-6 Controller [1]: Link input variable TR			
[1]	[2]		-0 Off			
[1]	[2]		-1 To input variable PV			
[1]	[2]		-2 To set point SP			
[1]	[2]		-3 To output YPID			
[1]	[2]	-5 To input variable DV <M.1-2/-6>				

Annex A (configuration guide)

Con- troller		C.3.2	Feedforward control	Default setting	Setting [1] [2]	
		C.3.2.4	Valuate input variable DV, TR <C.3.2.3≠0> M.1-2: Link input variable TR	C.3.2.4-1		
[1]	[2]	-1	Result pos./neg.			
[1]	[2]	-2	Result≥= 0			
[1]	[2]	-3	Result <= 0			
[1]	[2]	K5	Constant, formula: [-100.0 ... 100.0] (DV+TR*K5-K6)*K7+K8 M.1-2/-6 Controller [1]: without DV	0.00		
[1]	[2]	K6	Constant, formula: [-9999.0 ... 9999.0] (DV+TR*K5-K6)*K7+K8 M.1-2/-6 Controller [1]: without DV	0.0		
[1]	[2]	K7	Constant, formula: [-100.0 ... 100.0] (DV+TR*K5-K6)*K7+K8 M.1-2/-6 Controller [1]: without DV	1.00		
[1]	[2]	K8	Constant, formula: [-9999.0 ... 9999.0] (DV+TR*K5-K6)*K7+K8 M.1-2/-6 Controller [1]: without DV	0.0		
		C.3.2.5	Transfer function for disturbance variables <C.3.2.3≠0>	C.3.2.5-1		
[1]	[2]	-1	P behavior			
[1]	[2]	-2	D behavior 1			
[1]	[2]	-3	D behavior 2			
[1]	[2]	-4	D behavior 3			
[1]	[2]	-5	PD behavior			
[1]	[2]	KP.PD	Proportional-action coefficient [0.1 ...100.0]	1.0		
[1]	[2]	TV.PD	Derivative-action time [0.1 ... 9999 s] <C.3.2.5≠1>	0.1 s		
[1]	[2]	B.MIN	Minimum output value [-9999.0 ... 9999.0]	-9999.0 %		
[1]	[2]	B.MAX	Maximum output value [-9999.0 ... 9999.0]	9999.0 %		
		C.3.2.6	Arithmetic operation input variable PV	C.3.2.6-0		
[1]	[2]	-0	Off			
[1]	[2]	-1	PV + A <C.1.1.1-1/-2/-3/-4, C.3.2.1-1/C.3.2.3-1>			
[1]	[2]	-2	PV - A <C.1.1.1-1/-2/-3/-4, C.3.2.1-1/C.3.2.3-1>			
[1]	[2]	-3	PV * A <C.1.1.1-1/-2/-3/-4, C.3.2.1-1/C.3.2.3-1>			
[1]	[2]	-4	PV / A <C.1.1.1-1/-2/-3/-4, C.3.2.1-1/C.3.2.3-1>			
[1]	[2]	-5	(PV + A) / 2 <C.1.1.1-1/-2/-3/-4, C.3.2.1-1/C.3.2.3-1>			

Con- troller	C.3.2	Feedforward control	Default setting	Setting	
				[1]	[2]
[1] [2]	-6	Min (PV, A) <C.1.1.1-1/-2/-3/-4, C.3.2.1-1/C.3.2.3-1>			
[1] [2]	-7	Max (PV, A) <C.1.1.1-1/-2/-3/-4, C.3.2.1-1/C.3.2.3-1>			
[1] [2]	-8	PV – SPE <C.1.1.1-1/-2/-3/-4, C.1.2.1-1/-2/-3/-4>			
[1] [2]	-9	(PV + SPE) / 2 <C.1.1.1-1/-2/-3/-4, C.1.2.1-1/-2/-3/-4>			
[1] [2]	-10	Min (PV, SPE) <C.1.1.1-1/-2/-3/-4, C.1.2.1-1/-2/-3/-4>			
[1] [2]	-11	Max (PV, SPE) <C.1.1.1-1/-2/-3/-4, C.1.2.1-1/-2/-3/-4>			
[1] [2]	-12	PV – DV <C.1.1.1-1/-2/-3/-4, C.1.3.1-1/-2/-3/-4>			
[1] [2]	-13	(PV – DV) / 2 <C.1.1.1-1/-2/-3/-4, C.1.3.1-1/-2/-3/-4>			
[1] [2]	-14	Min (PV, DV) <C.1.1.1-1/-2/-3/-4, C.1.3.1-1/-2/-3/-4>			
[1] [2]	-15	Max (PV, DV) <C.1.1.1-1/-2/-3/-4, C.1.3.1-1/-2/-3/-4>			
[1] [2]	-16	(PV + SPE + DV) / 3 <C.1.1.1-1/-2/-3/-4, C.1.2.1-1/-2/-3/-4, C.1.3.1-1/-2/-3/-4>			
[1] [2]	-17	Min (PV, SPE, DV) <C.1.1.1-1/-2/-3/-4, C.1.2.1-1/-2/-3/-4, C.1.3.1-1/-2/-3/-4>			
[1] [2]	-18	Max (PV, SPE, DV) <C.1.1.1-1/-2/-3/-4, C.1.2.1-1/-2/-3/-4, C.1.3.1-1/-2/-3/-4>			
[1] [2]	-19	(PV + SPE + DV + TR) / 4 <C.1.1.1-1/-2/-3/-4, C.1.2.1-1/-2/-3/-4, C.1.3.1-1/-2/-3/-4, C.1.4.1-1/-2/-3/-4>			
[1] [2]	-20	Min (PV, SPE, DV, TR) <C.1.1.1-1/-2/-3/-4, C.1.2.1-1/-2/-3/-4, C.1.3.1-1/-2/-3/-4, C.1.4.1-1/-2/-3/-4>			
[1] [2]	-21	Max (PV, SPE, DV, TR) <C.1.1.1-1/-2/-3/-4, C.1.2.1-1/-2/-3/-4, C.1.3.1-1/-2/-3/-4, C.1.4.1-1/-2/-3/-4>			

Annex A (configuration guide)

Con- troller		C.3.2	Feedforward control	Default setting	Setting [1] [2]	
[1]	[2]	C3.2.7	Arithmetic operation input variable DV <M.1-2/-6, C.3.2.3-5>	C.3.2.7-0		
[1]	[2]		-0 Off			
[1]	[2]		-1 DV + B			
[1]	[2]		-2 DV – B			
[1]	[2]		-3 DV * B			
[1]	[2]	-4 DV / B				
[1]	[2]	C3.2.8	Arithmetic operation set point SP <C.3.2.3-2>	C.3.2.8-0		
[1]	[2]		-0 Off			
[1]	[2]		-1 SP + B			
[1]	[2]		-2 SP – B			
[1]	[2]		-3 SP * B			
[1]	[2]	-4 SP / B				
[1]	[2]	C3.2.9	Arithmetic operation output YPID <C.3.2.3-3>	C.3.2.9-0		
[1]	[2]		-0 Off			
[1]	[2]		-1 YPID + B			
[1]	[2]		-2 YPID – B			
[1]	[2]		-3 YPID * B			
[1]	[2]	-4 YPID / B				

Con- troller		C.3.3	Additional control functions	Default setting	Setting [1] [2]	
[1]	[2]	C.3.3.1	Change over to manual mode DI M.1-3/-4: Controller [1] only	C.3.3.1-0		
[1]	[2]		-0 Off			
[1]	[2]		-1 With digital input DI1			
[1]	[2]		-2 With digital input DI2			
[1]	[2]		-3 With digital input DI3			
[1]	[2]	-4 With digital input DI4				
[1]	[2]	C.3.3.2	Hold output YPID with DI	C.3.3.2-0		
[1]	[2]		-0 Off			
[1]	[2]		-1 With digital input DI1			
[1]	[2]		-2 With digital input DI2			
[1]	[2]		-3 With digital input DI3			
[1]	[2]	-4 With digital input DI4				

Con- troller		C.3.3	Additional control functions	Default setting	Setting [1] [2]	
[1]	[2]	C.3.3.3	Output tracking <C.1.4.1-1/-2/-3/-4> M.1-1/-2/-3/-5/-6; M.1-4: Controller [1] only	C.3.3.3-0		
		-0	Off			
[1]	[2]	-1	With input TR, DI1			
[1]	[2]	-2	With input TR, DI2			
[1]	[2]	-3	With input TR, DI3			
[1]	[2]	-4	With input TR, DI4			
[1]	[2]	C.3.3.6	Increase/decrease actual value with DI	C.3.3.6-0		
		-0	Off			
[1]	[2]	-1	With digital input DI1			
[1]	[2]	-2	With digital input DI2			
[1]	[2]	-3	With digital input DI3			
[1]	[2]	-4	With digital input DI4			
[1]	[2]	K9	Constant to increase/decrease actual value [-999.0 ... 9999.0]	0.0		
[1]	[2]	C.3.3.7	Limit output in manual mode M.1-3/-4: Controller [1] only	C.3.3.7-1		
		-0	Off			
[1]	[2]	-1	On			
[2]	[2]	C.3.3.8	Limit master controller output YM <M.1-3>	C.3.3.8-0		
		-0	Off			
[2]	[2]	-1	Min/Max value = constant			
[2]	[2]	-2	Minimum value = f(SPO)			
[2]	[2]	-3	Maximum value = f(SPO)			
[2]	[2]	-4	Min/Max value = f(SPO)			
[2]	[2]	YM.MIN	Minimum value output master controller <C.3.3.8≠0> [-10.0 ... 110.0 %]	0.0 %		
[2]	[2]	YM.MAX	Maximum value output master controller <C.3.3.8≠0> [-10.0 ... 110.0 %]	100.0 %		
[2]	[2]	YM.K1	Constant minimum value = SP - YM.K1 <C.3.3.8-2/-4> [0.0 ... 100.0 %]	100.0 %		
[2]	[2]	YM.K2	Constant maximum value = SP + YM.K2 <C.3.3.8-3/-4> [0.0 ... 100.0 %]	100.0 %		

Annex A (configuration guide)

Con- troller		C.4	Restart conditions	Default setting	Setting	
					[1]	[2]
		C.4.1	Operation mode after restart	C.4.1-0		
[1]	[2]	-0	Auto			
[1]	[2]	-1	Auto, start AO1 = AO1.K1 <0.1.1-1/-2/-38/-39>			
[1]	[2]	-2	Auto, start AO2 = AO2.K1 <0.2.1-1/-2/-38/-39>			
[1]	[2]	-3	Auto, start AO3 = AO3.K1 <0.3.1-1/-2/-38/-39>			
[1]	[2]	-4	Auto, start SO1 = SO1.K1 <0.4.1-1/-2/-38/-39>			
[1]	[2]	-5	Auto, start SO2 = SO2.K1 <0.5.1-1/-2/-38/-39>			
[1]	[2]	-6	Manual, start AO1 = AO1.K1 <0.1.1-1/-2/-38/-39>			
[1]	[2]	-7	Manual, start AO2 = AO2.K1 <0.2.1-1/-2/-38/-39>			
[1]	[2]	-8	Manual, start AO3 = AO3.K1 <0.3.1-1/-2/-38/-39>			
[1]	[2]	-9	Manual, start SO1 = SO1.K1 <0.4.1-1/-2/-38/-39>			
[1]	[2]	-10	Manual, start SO2 = SO2.K2 <0.5.1-1/-2/-38/-39>			
[1]	[2]	-11	Auto, confirm. AO1 = AO1.K1 <0.1.1-1/-2/-38/-39>			
[1]	[2]	-12	Auto, confirm. AO2 = AO2.K1 <0.2.1-1/-2/-38/-39>			
[1]	[2]	-13	Auto, confirm. AO3 = AO3.K1 <0.3.1-1/-2/-38/-39>			
[1]	[2]	-14	Auto, confirm. SO1 = SO1.K1 <0.4.1-1/-2/-38/-39>			
[1]	[2]	-15	Auto, confirm. SO2 = SO2.K1 <0.5.1-1/-2/-38/-39>			
[1]	[2]	AO1.K1	Constant output value at AO1 <C.4.1-1/-6/-11> [-10.0 ... 110.0 %]			
[1]	[2]	AO2.K1	Constant output value at AO2 <C.4.1-2/-7/-12> [-10.0 ... 110.0 %]			
[1]	[2]	AO3.K1	Constant output value at AO3 <C.4.1-3/-8/-13> [-10.0 ... 110.0 %]			
[1]	[2]	SO1.K1	Constant output value at AO1 <C.4.1-4/-9/-14> [-10.0 ... 110.0 %]			
[1]	[2]	SO2.K1	Constant output value at SO2 <C.4.1-5/-10/-15> [-10.0 ... 110.0 %]			
Con- troller		C.5	Controller display	Default setting	Setting	
					[1]	[2]
		C.5.1	Row 1	C.5.1-1		
[1]	[2]	-0	Off	Ratio con- troller:		
[1]	[2]	-1	Actual value PV0 at comparator	C.5.1-4		
[1]	[2]	-2	Input PV after function generation			
[1]	[2]	-3	Input PV before filter			
[1]	[2]	-4	Actual ratio PVR <M.1-2/-6>			
		C.5.2	Row 2	C.5.2-1		
[1]	[2]	-0	Off			
[1]	[2]	-1	Error signal +/-e			
[1]	[2]	-2	Abs. error signal e			

Con- troller		C.5	Controller display	Default setting	Setting [1] [2]	
[1]	[2]	C.5.3	Row 3	C.5.3-1 Ratio con- troller: C.5.3-3		
[1]	[2]		-0 Off			
[1]	[2]		-1 SP1 ... SP4, SPE, SPC · SPM with M.1-3 Controller [2]			
[1]	[2]		-2 Set point SP0 at comparator			
[1]			-3 Set point ratio SPR <M.1-2/-6>			
[1]	[2]	C.5.4	Row 4	C.5.4-1		
[1]	[2]		-0 Off			
[1]	[2]		-1 Output according to priority			
[1]	[2]		-2 Output AO1 <O.1.1≠0>			
[1]	[2]		-3 Output AO2 <O.2.1≠0>			
[1]	[2]		-4 Output AO3 <O.3.1≠0>			
[1]	[2]		-5 Output SO1 <O.4.1≠0>			
[1]	[2]		-6 Output SO2 <O.5.1≠0>			
[1]			-7 Controller [1] output Y			
	[2]		-8 Controller [2] output Y			
	[2]		-10 Output master controller YM <M.1-3>			
[1]	[2]		-11 Input PV before filter <C.1.1.1≠0>			
[1]	[2]		-12 Input PV after function generation <C.1.1.1≠0>			
[1]	[2]		-13 Actual value PV0 at comparator <C.1.1.1≠0>			
[1]			-14 Actual ratio PVR <M.1-2/-6>			
[1]	[2]		-15 Input SPE before filter <C.1.2.1≠0>			
[1]	[2]		-16 Input SPE after function generation <C.1.2.1≠0>			
[1]	[2]		-17 Input DV before filter <C.1.3.1≠0>			
[1]	[2]		-18 Input DV after function generation <C.1.3.1≠0>			
[1]	[2]		-19 Input TR before filter <C.1.4.1≠0>			
[1]	[2]		-20 Input TR after function generation <C.1.4.1≠0>			
[1]	[2]		-22 Input FB before filter <C.1.5.1≠0>			
[1]	[2]		-23 Input FB after filter <C.1.5.1≠0>			
[1]	[2]		-24 Signal A <C.3.2.1≠0/C.3.2.3≠0>			
[1]	[2]		-25 Signal B <C.3.2.3≠0>			
[1]	[2]		-26 Set point SP1 <C.2.1.1-1/-2/-3/-4>			
[1]	[2]		-27 Set point SP2 <C.2.1.1-2/-3/-4>			
[1]	[2]		-28 Set point SP3 <C.2.1.1-3/-4>			
[1]	[2]		-29 Set point SP4 <C.2.1.1-4>			
[1]	[2]		-30 Set point SPI			
[1]			-31 Set point SPM <M.1-3>			
[1]	[2]		-32 Set point SPC <C.2.1.2-2>			

Annex A (configuration guide)

Con- troller	C.5	Controller display	Default setting	Setting	
				[1]	[2]
[1]	[2]	-33 Set point SP			
[1]	[2]	-34 Set point SP0 at comparator			
[1]		-35 Set point ratio SPR <M.1-2/-6>			
[1]	[2]	-36 Error signal +/-e			
[1]	[2]	-37 Digital outputs DO1...4 <0.6.1≠0/0.7.1≠0/0.8.1≠0/0.9.1≠0>			
[1]	[2]	-38 Digital outputs DO5...7			
[1]	[2]	-39 Digital inputs DI1...4			
[1]	[2]	-40 KP			
[1]	[2]	-41 TN			
		C.5.5 Row 4 representation	C.5.5-1		
[1]	[2]	-1 Numerical	C.5.5-5, if		
[1]	[2]	-2 Numerical, inverted	C.5.4-5/-6		
[1]	[2]	-3 Bar graph	C.5.5-6, if		
[1]	[2]	-4 Bar graph, inverted	C.5.4-37/ -38/-39		
[1]	[2]	-5 Switching signal			
[1]	[2]	-6 Digital signal			
		C.5.6 Row 5	C.5.6-0		
[1]	[2]	-0 Off			
[1]	[2]	-1 Output according to priority			
[1]	[2]	-2 Output AO1 <0.1.1≠0>			
[1]	[2]	-3 Output AO2 <0.2.1≠0>			
[1]	[2]	-4 Output AO3 <0.3.1≠0>			
[1]	[2]	-5 Output SO1 <0.4.1≠0>			
[1]	[2]	-6 Output SO2 <0.5.1≠0>			
[1]		-7 Controller [1] output Y			
	[2]	-8 Controller [2] output Y			
	[2]	-10 Output master controller YM <M.1-3>			
[1]	[2]	-11 Input PV before filter <C.1.1.1≠0>			
[1]	[2]	-12 Input PV after function generation <C.1.1.1≠0>			
[1]	[2]	-13 Actual value PV0 at comparator <C.1.1.1≠0>			
[1]		-14 Actual ratio PVR <M.1-2/-6>			
[1]	[2]	-15 Input SPE before filter <C.1.2.1≠0>			
[1]	[2]	-16 Input SPE after function generation <C.1.2.1≠0>			
[1]	[2]	-17 Input DV before filter <C.1.3.1≠0>			
[1]	[2]	-18 Input DV after function generation <C.1.3.1≠0>			
[1]	[2]	-19 Input TR before filter <C.1.4.1≠0>			

Con- troller	C.5	Controller display	Default setting	Setting		
				[1]	[2]	
[1]	[2]	-20	Input TR after function generation <C.1.4.1≠0>			
[1]	[2]	-22	Input FB before filter <C.1.5.1≠0>			
[1]	[2]	-23	Input FB after filter <C.1.5.1≠0>			
[1]	[2]	-24	Signal A <C.3.2.1≠0/C.3.2.3≠0>			
[1]	[2]	-25	Signal B <C.3.2.3≠0>			
[1]	[2]	-26	Set point SP1 <C.2.1.1-1/-2/-3/-4>			
[1]	[2]	-27	Set point SP2 <C.2.1.1-2/-3/-4>			
[1]	[2]	-28	Set point SP3 <C.2.1.1-3/-4>			
[1]	[2]	-29	Set point SP4 <C.2.1.1-4>			
[1]	[2]	-30	Set point SPI			
[1]		-31	Set point SPM <M.1-3>			
[1]	[2]	-32	Set point SPC <C.2.1.2-2>			
[1]	[2]	-33	Set point SP			
[1]	[2]	-34	Set point SP0 at comparator			
[1]		-35	Set point ratio SPR <M.1-2/-6>			
[1]	[2]	-36	Error signal +/-e			
[1]	[2]	-37	Digital outputs DO1...4 <O.6.1≠0/O.7.1≠0/O.8.1≠0/O.9.1≠0>			
[1]	[2]	-38	Digital outputs DO5...7			
[1]	[2]	-39	Digital inputs DI1...4			
[1]	[2]	-40	Effective KP			
[1]	[2]	-41	Effective TN			
		C.5.7	Row 5 representation	C.5.7-1		
[1]	[2]	-1	Numerical	C.5.7-5, if		
[1]	[2]	-2	Numerical, inverted	C.5.6-5/-6		
[1]	[2]	-3	Bar graph	C.5.7-6, if		
[1]	[2]	-4	Bar graph, inverted	C.5.6-37/ -38/-39		
[1]	[2]	-5	Switching signal			
[1]	[2]	-6	Digital signal			
Con- troller	C.6	Additional display		Default setting	Setting	
		C.6.1	Row 1	C.6.1-1		
[1]	[2]	-0	Off			
[1]	[2]	-1	Output according to priority			
[1]	[2]	-2	Output AO1 <O.1.1≠0>			
[1]	[2]	-3	Output AO2 <O.2.1≠0>			
[1]	[2]	-4	Output AO3 <O.3.1≠0>			

Annex A (configuration guide)

Con- troller	C.6	Additional display	Default setting	Setting	
				[1]	[2]
[1]	[2]	-5 Output SO1 <O.4.1≠0>			
[1]	[2]	-6 Output SO2 <O.5.1≠0>			
[1]		-7 Controller [1] output Y			
	[2]	-8 Controller [2] output Y			
	[2]	-10 Output master controller YM <M.1-3>			
[1]	[2]	-11 Input PV before filter <C.1.1.1≠0>			
[1]	[2]	-12 Input PV after function generation <C.1.1.1≠0>			
[1]	[2]	-13 Actual value PV0 at comparator <C.1.1.1≠0>			
[1]		-14 Actual ratio PVR <M.1-2/-6>			
[1]	[2]	-15 Input SPE before filter <C.1.2.1≠0>			
[1]	[2]	-16 Input SPE after function generation <C.1.2.1≠0>			
[1]	[2]	-17 Input DV before filter <C.1.3.1≠0>			
[1]	[2]	-18 Input DV after function generation <C.1.3.1≠0>			
[1]	[2]	-19 Input TR before filter <C.1.4.1≠0>			
[1]	[2]	-20 Input TR after function generation <C.1.4.1≠0>			
[1]	[2]	-22 Input FB before filter <C.1.5.1≠0>			
[1]	[2]	-23 Input FB after filter <C.1.5.1≠0>			
[1]	[2]	-24 Signal A <C.3.2.1≠0/C.3.2.3≠0>			
[1]	[2]	-25 Signal B <C.3.2.3≠0>			
[1]	[2]	-26 Set point SP1 <C.2.1.1-1/-2/-3/-4>			
[1]	[2]	-27 Set point SP2 <C.2.1.1-2/-3/-4>			
[1]	[2]	-28 Set point SP3 <C.2.1.1-3/-4>			
[1]	[2]	-29 Set point SP4 <C.2.1.1-4>			
[1]	[2]	-30 Set point SPI			
[1]		-31 Set point SPM <M.1-3>			
[1]	[2]	-32 Set point SPC <C.2.1.2-2>			
[1]	[2]	-33 Set point SP			
[1]	[2]	-34 Set point SP0 at comparator			
[1]		-35 Set point ratio SPR <M.1-2/-6>			
[1]	[2]	-36 Error signal +/-e			
[1]	[2]	-37 Digital outputs DO1...4 <O.6.1≠0/O.7.1≠0/O.8.1≠0/O.9.1≠0>			
[1]	[2]	-38 Digital outputs DO5...7			
[1]	[2]	-39 Digital inputs DI1...4			
[1]	[2]	-40 Effective KP			
[1]	[2]	-41 Effective TN			

Con- troller		C.6	Additional display	Default setting	Setting [1] [2]	
		C.6.2	Row 1 representation <C.6.1≠0>	C.6.2-1		
[1]	[2]	-1	Numerical	C.6.2-5, if		
[1]	[2]	-2	Numerical, inverted	C.6.1-5/-6		
[1]	[2]	-3	Bar graph	C.6.2-6, if		
[1]	[2]	-4	Bar graph, inverted	C.6.1-37/ -38/-39		
[1]	[2]	-5	Switching signal			
[1]	[2]	-6	Digital signal			
		C.6.3	Row 2	C.6.3-1		
[1]	[2]	-0	Off			
[1]	[2]	-1	Output according to priority			
[1]	[2]	-2	Output AO1 <O.1.1≠0>			
[1]	[2]	-3	Output AO2 <O.2.1≠0>			
[1]	[2]	-4	Output AO3 <O.3.1≠0>			
[1]	[2]	-5	Output SO1 <O.4.1≠0>			
[1]	[2]	-6	Output SO2 <O.5.1≠0>			
[1]		-7	Controller [1] output Y			
	[2]	-8	Controller [2] output Y			
	[2]	-10	Output master controller YM <M.1-3>			
[1]	[2]	-11	Input PV before filter <C.1.1.1≠0>			
[1]	[2]	-12	Input PV after function generation <C.1.1.1≠0>			
[1]	[2]	-13	Actual value PVO at comparator <C.1.1.1≠0>			
[1]		-14	Actual ratio PVR <M.1-2/-6>			
[1]	[2]	-15	Input SPE before filter <C.1.2.1≠0>			
[1]	[2]	-16	Input SPE after function generation <C.1.2.1≠0>			
[1]	[2]	-17	Input DV before filter <C.1.3.1≠0>			
[1]	[2]	-18	Input DV after function generation <C.1.3.1≠0>			
[1]	[2]	-19	Input TR before filter <C.1.4.1≠0>			
[1]	[2]	-20	Input TR after function generation <C.1.4.1≠0>			
[1]	[2]	-22	Input FB before filter <C.1.5.1≠0>			
[1]	[2]	-23	Input FB after filter <C.1.5.1≠0>			
[1]	[2]	-24	Signal A <C.3.2.1≠0/C.3.2.3≠0>			
[1]	[2]	-25	Signal B <C.3.2.3≠0>			
[1]	[2]	-26	Set point SP1 <C.2.1.1-1/-2/-3/-4>			
[1]	[2]	-27	Set point SP2 <C.2.1.1-2/-3/-4>			
[1]	[2]	-28	Set point SP3 <C.2.1.1-3/-4>			
[1]	[2]	-29	Set point SP4 <C.2.1.1-4>			
[1]	[2]	-30	Set point SPI			

Annex A (configuration guide)

Con- troller	C.6	Additional display	Default setting	Setting	
				[1]	[2]
[1]		-31 Set point SPM <M.1-3>			
[1]	[2]	-32 Set point SPC <C.2.1.2-2>			
[1]	[2]	-33 Set point SP			
[1]	[2]	-34 Set point SP0 at comparator			
[1]		-35 Set point ratio SPR <M.1-2/-6>			
[1]	[2]	-36 Error signal +/-e			
[1]	[2]	-37 Digital outputs DO1...4			
[1]		<O.6.1≠0/O.7.1≠0/O.8.1≠0/O.9.1≠0>			
[1]	[2]	-38 Digital outputs DO5...7			
	[2]	-39 Digital inputs DI1...4			
[1]	[2]	-40 Effective KP			
[1]	[2]	-41 Effective TN			
		C.6.4			
		Row 2 representation <C.6.3≠0>	C.6.4-1		
[1]	[2]	-1 Numerical	C.6.4-5, if		
[1]	[2]	-2 Numerical, inverted	C.6.3-5/-6		
[1]	[2]	-3 Bar graph	C.6.4-6, if		
[1]	[2]	-4 Bar graph, inverted	C.6.3-37/ -38/-39		
[1]	[2]	-5 Switching signal			
[1]	[2]	-6 Digital signal			
		C.6.5			
		Row 3	C.6.5-1		
[1]	[2]	-0 Off			
[1]	[2]	-1 Output according to priority			
[1]	[2]	-2 Output AO1 <O.1.1≠0>			
[1]	[2]	-3 Output AO2 <O.2.1≠0>			
[1]	[2]	-4 Output AO3 <O.3.1≠0>			
[1]	[2]	-5 Output SO1 <O.4.1≠0>			
[1]	[2]	-6 Output SO2 <O.5.1≠0>			
[1]		-7 Controller [1] output Y			
	[2]	-8 Controller [2] output Y			
	[2]	-10 Output master controller YM <M.1-3>			
[1]	[2]	-11 Input PV before filter <C.1.1.1≠0>			
[1]	[2]	-12 Input PV after function generation <C.1.1.1≠0>			
[1]	[2]	-13 Actual value PV0 at comparator <C.1.1.1≠0>			
[1]		-14 Actual ratio PVR <M.1-2/-6>			
[1]	[2]	-15 Input SPE before filter <C.1.2.1≠0>			
[1]	[2]	-16 Input SPE after function generation <C.1.2.1≠0>			
[1]	[2]	-17 Input DV before filter <C.1.3.1≠0>			

Con- troller	C.6	Additional display	Default setting	Setting	
				[1]	[2]
[1] [2]	-18	Input DV after function generation <C.1.3.1≠0>			
[1] [2]	-19	Input TR before filter <C.1.4.1≠0>			
[1] [2]	-20	Input TR after function generation <C.1.4.1≠0>			
[1] [2]	-22	Input FB before filter <C.1.5.1≠0>			
[1] [2]	-23	Input FB after filter <C.1.5.1≠0>			
[1] [2]	-24	Signal A <C.3.2.1≠0/C.3.2.3≠0>			
[1] [2]	-25	Signal B <C.3.2.3≠0>			
[1] [2]	-26	Set point SP1 <C.2.1.1-1/-2/-3/-4>			
[1] [2]	-27	Set point SP2 <C.2.1.1-2/-3/-4>			
[1] [2]	-28	Set point SP3 <C.2.1.1-3/-4>			
[1] [2]	-29	Set point SP4 <C.2.1.1-4>			
[1] [2]	-30	Set point SPI			
[1] [2]	-31	Set point SPM <M.1-3>			
[1] [2]	-32	Set point SPC <C.2.1.2-2>			
[1] [2]	-33	Set point SP			
[1] [2]	-34	Set point SP0 at comparator			
[1] [2]	-35	Set point ratio SPR <M.1-2/-6>			
[1] [2]	-36	Error signal +/-e			
[1] [2]	-37	Digital outputs DO1...4 <O.6.1≠0/O.7.1≠0/O.8.1≠0/O.9.1≠0>			
[1] [2]	-38	Digital outputs DO5...7			
[1] [2]	-39	Digital inputs DI1...4			
[1] [2]	-40	Effective KP			
[1] [2]	-41	Effective TN			
	C.6.6	Row 3 representation <C.6.5≠0>	C.6.6-1		
[1] [2]	-1	Numerical	C.6.6-5, if		
[1] [2]	-2	Numerical, inverted	C.6.5-5/-6		
[1] [2]	-3	Bar graph	C.6.6-6, if		
[1] [2]	-4	Bar graph, inverted	C.6.5-37/ -38/-39		
[1] [2]	-5	Switching signal			
[1] [2]	-6	Digital signal			
	C.6.7	Row 4	C.6.7-1		
[1] [2]	-0	Off			
[1] [2]	-1	Output according to priority			
[1] [2]	-2	Output AO1 <O.1.1≠0>			
[1] [2]	-3	Output AO2 <O.2.1≠0>			
[1] [2]	-4	Output AO3 <O.3.1≠0>			

Annex A (configuration guide)

Con- troller	C.6	Additional display	Default setting	Setting	
				[1]	[2]
[1]	[2]	-5 Output SO1 <O.4.1≠0>			
[1]	[2]	-6 Output SO2 <O.5.1≠0>			
[1]		-7 Controller [1] output Y			
	[2]	-8 Controller [2] output Y			
	[2]	-10 Output master controller YM <M.1-3>			
[1]	[2]	-11 Input PV before filter <C.1.1.1≠0>			
[1]	[2]	-12 Input PV after function generation <C.1.1.1≠0>			
[1]	[2]	-13 Actual value PV0 at comparator <C.1.1.1≠0>			
[1]		-14 Actual ratio PVR <M.1-2/-6>			
[1]	[2]	-15 Input SPE before filter <C.1.2.1≠0>			
[1]	[2]	-16 Input SPE after function generation <C.1.2.1≠0>			
[1]	[2]	-17 Input DV before filter <C.1.3.1≠0>			
[1]	[2]	-18 Input DV after function generation <C.1.3.1≠0>			
[1]	[2]	-19 Input TR before filter <C.1.4.1≠0>			
[1]	[2]	-20 Input TR after function generation <C.1.4.1≠0>			
[1]	[2]	-22 Input FB before filter <C.1.5.1≠0>			
[1]	[2]	-23 Input FB after filter <C.1.5.1≠0>			
[1]	[2]	-24 Signal A <C.3.2.1≠0/C.3.2.3≠0>			
[1]	[2]	-25 Signal B <C.3.2.3≠0>			
[1]	[2]	-26 Set point SP1 <C.2.1.1-1/-2/-3/-4>			
[1]	[2]	-27 Set point SP2 <C.2.1.1-2/-3/-4>			
[1]	[2]	-28 Set point SP3 <C.2.1.1-3/-4>			
[1]	[2]	-29 Set point SP4 <C.2.1.1-4>			
[1]	[2]	-30 Set point SPI			
[1]		-31 Set point SPM <M.1-3>			
[1]	[2]	-32 Set point SPC <C.2.1.2-2>			
[1]	[2]	-33 Set point SP			
[1]	[2]	-34 Set point SP0 at comparator			
[1]		-35 Set point ratio SPR <M.1-2/-6>			
[1]	[2]	-36 Error signal +/-e			
[1]	[2]	-37 Digital outputs DO1...4 <O.6.1≠0/O.7.1≠0/O.8.1≠0/O.9.1≠0>			
[1]	[2]	-38 Digital outputs DO5...7			
	[2]	-39 Digital inputs DI1...4			
[1]	[2]	-40 Effective KP			
[1]	[2]	-41 Effective TN			

Con- troller		C.6	Additional display	Default setting	Setting [1] [2]	
		C.6.8	Row 4 representation <C.6.7≠0>	C.6.8-1		
[1]	[2]	-1	Numerical	C.6.8-5, if		
[1]	[2]	-2	Numerical, inverted	C.6.7-5/-6		
[1]	[2]	-3	Bar graph	C.6.8-6, if		
[1]	[2]	-4	Bar graph, inverted	C.6.7-37/ -38/-39		
[1]	[2]	-5	Switching signal			
[1]	[2]	-6	Digital signal			
		C.6.9	Row 5	C.6.9-1		
[1]	[2]	-0	Off			
[1]	[2]	-1	Output according to priority			
[1]	[2]	-2	Output AO1 <O.1.1≠0>			
[1]	[2]	-3	Output AO2 <O.2.1≠0>			
[1]	[2]	-4	Output AO3 <O.3.1≠0>			
[1]	[2]	-5	Output SO1 <O.4.1≠0>			
[1]	[2]	-6	Output SO2 <O.5.1≠0>			
[1]		-7	Controller [1] output Y			
	[2]	-8	Controller [2] output Y			
	[2]	-10	Output master controller YM <M.1-3>			
[1]	[2]	-11	Input PV before filter <C.1.1.1≠0>			
[1]	[2]	-12	Input PV after function generation <C.1.1.1≠0>			
[1]	[2]	-13	Actual value PV0 at comparator <C.1.1.1≠0>			
[1]		-14	Actual ratio PVR <M.1-2/-6>			
[1]	[2]	-15	Input SPE before filter <C.1.2.1≠0>			
[1]	[2]	-16	Input SPE after function generation <C.1.2.1≠0>			
[1]	[2]	-17	Input DV before filter <C.1.3.1≠0>			
[1]	[2]	-18	Input DV after function generation <C.1.3.1≠0>			
[1]	[2]	-19	Input TR before filter <C.1.4.1≠0>			
[1]	[2]	-20	Input TR after function generation <C.1.4.1≠0>			
[1]	[2]	-22	Input FB before filter <C.1.5.1≠0>			
[1]	[2]	-23	Input FB after filter <C.1.5.1≠0>			
[1]	[2]	-24	Signal A <C.3.2.1≠0/C.3.2.3≠0>			
[1]	[2]	-25	Signal B <C.3.2.3≠0>			
[1]	[2]	-26	Set point SP1 <C.2.1.1-1/-2/-3/-4>			
[1]	[2]	-27	Set point SP2 <C.2.1.1-2/-3/-4>			
[1]	[2]	-28	Set point SP3 <C.2.1.1-3/-4>			
[1]	[2]	-29	Set point SP4 <C.2.1.1-4>			
[1]	[2]	-30	Set point SPI			

Annex A (configuration guide)

Con- troller		C.6	Additional display	Default setting	Setting	
					[1]	[2]
[1]		-31	Set point SPM <M.1-3>			
[1]	[2]	-32	Set point SPC <C.2.1.2-2>			
[1]	[2]	-33	Set point SP			
[1]	[2]	-34	Set point SPO at comparator			
[1]		-35	Set point ratio SPR <M.1-2/-6>			
[1]	[2]	-36	Error signal +/-e			
[1]	[2]	-37	Digital outputs DO1...4 <O.6.1≠0/O.7.1≠0/O.8.1≠0/O.9.1≠0>			
[1]	[2]	-38	Digital outputs DO5...7			
	[2]	-39	Digital inputs DI1...4			
[1]	[2]	-40	Effective KP			
[1]	[2]	-41	Effective TN			
		C.6.10	Row 5 representation <C.6.9≠0>	C.6.10-1		
[1]	[2]	-1	Numerical	C.6.10-5, if		
[1]	[2]	-2	Numerical, inverted	C.6.9-5/-6		
[1]	[2]	-3	Bar graph	C.6.10-6, if		
[1]	[2]	-4	Bar graph, inverted	C.6.9-37/ -38/-39		
[1]	[2]	-5	Switching signal			
[1]	[2]	-6	Digital signal			
Con- troller		C.7	Operating keys	Default setting	Setting	
					[1]	[2]
		C.7.1	Invert manual output value	C.7.1-0		
[1]	[2]	-0	Off			
[1]	[2]	-1	On			
		C.7.2	Lock manual/automatic key	C.7.2-0		
[1]	[2]	-0	Off			
[1]	[2]	-1	On			
		C.7.3	Lock set point keys	C.7.3-0		
[1]	[2]	-0	Off			
[1]	[2]	-1	On			

O Output

O.1	Analog output AO1	Default setting	Setting
O.1.1 -0 Off -1 Controller [1] output Y -2 Controller [2] output Y <M.1-3/-4/-5/-6> -4 Constant positioning value -5 [1] Input PV before filter <1C.1.1.1≠0> -6 [1] Input PV after function generation <1C.1.1.1≠0> -7 [1] Actual value PVO <1C.1.1.1≠0> -8 [1] Input SPE before filter <1C.1.2.1≠0> -9 [1] Input SPE after function generation <1C.1.2.1≠0> -10 [1] Input DV before filter <1C.1.3.1≠0> -11 [1] Input DV after function generation <1C.1.3.1≠0> -12 [1] Input TR before filter <1C.1.4.1≠0> -13 [1] Input TR after function generation <1C.1.4.1≠0> -14 [1] Input FB before filter <1C.1.5.1≠0> -15 [1] Signal A <1C.3.2.1-1/1C.3.2.3-1> -16 [1] Signal B <1C.3.2.3≠0> -17 [1] Set point SP0 -18 [1] Error signal +/-e -19 [1] Abs. error signal e -20 [1] Set point ratio SPR <M.1-2/-6> -21 [1] Actual ratio PVR <M.1-2/-6> -22 [2] Input PV before filter <M.1-3/-4/-5/-6, 2C.1.1.1≠0> -23 [2] Input PV after function generation <M.1-3/-4/-5/-6, 2C.1.1.1≠0> -24 [2] Actual value PVO <M.1-3/-4/-5/-6, 2C.1.1.1≠0> -25 [2] Input SPE before filter <M.1-3/-4/-5/-6, 2C.1.2.1≠0> -26 [2] Input SPE after function generation <M.1-3/-4/-5/-6, 2C.1.2.1≠0> -27 [2] Input DV before filter <M.1-3/-4/-5/-6, 2C.1.3.1≠0> -28 [2] Input DV after function generation <M.1-3/-4/-5/-6, 2C.1.3.1≠0> -29 [2] Input TR before filter <M.1-3/-4/-5/-6, 2C.1.4.1≠0> -30 [2] Input TR after function generation <M.1-3/-4/-5/-6, 2C.1.4.1≠0> -31 [2] Input FB before filter <M.1-3/-4/-5/-6, 2C.1.5.1≠0> -32 [2] Signal A <M.1-3/-4/-5/-6, 2C.3.2.1-1, 2C.3.2.3-1> -33 [2] Signal B <M.1-3/-4/-5/-6, 2C.3.2.3≠0> -34 [2] Set point SP0 <M.1-3/-4/-5/-6> -35 [2] Error signal +/-e <M.1-3/-4/-5/-6>	Assign source	O.1.1-1	

Annex A (configuration guide)

O.1	Analog output AO1	Default setting	Setting
-36	[2] Abs. error signal e <M.1-3/-4/-5/-6>		
-37	Output master controller YM <M.1-3>		
-38	$Y1*Y2*AO1.KM/100$ <M.1-5/-6>		
-39	$(100-Y1)*Y2*AO1.KM/100$ <M.1-5/-6>		
AO1.FX	Constant output value <O.1.1-4> [-10.0 ... 110.0 %]	0.0 %	
AO1.KM	Constant, mixing operation <O.1.1-38/-39> [0.0 ... 100.0 %]	1.0	
O.1.2	Output signal <O.1.1≠0>	O.1.2-1	
-1	4-20 mA		
-2	0-20 mA		
-3	0-10 V		
-4	2-10 V		
AO1.MIN	Minimum output value [-10.0 ... 110.0 %]	0.0 %	
AO1.MAX	Maximum output value [-10.0 ... 110.0 %]	100.0 %	
O.1.3	Operating direction <O.1.1≠0>	O.1.3-1	
-1	Increasing		
-2	Decreasing		
AO1.P1	Y value for AO1=AO1.MIN <O.1.3-1> [-10.0 ... 110.0 %] Y value for AO1=AO1.MAX <O.1.3-2> The default value of AO1.P1 is the same as AO1.MIN. If AO1.MIN is changed, AO1.P1 is set to AO1.MIN.	0.0 %	
AO1.P2	Y value for AO1=AO1.MAX <O.1.3-1> [-10.0 ... 110.0 %] Y value for AO1=AO1.MIN <O.1.3-2> The default value of AO1.P2 is the same as AO1.MAX. If AO1.MAX is changed, AO1.P2 is set to AO1.MAX.	100.0 %	
O.1.4	Output ramp <O.1.1≠0, O.1.5-0>	O.1.4-1	
-0	Off		
-1	Start with DI1		
-2	Start with DI2		
-3	Start with DI3		
-4	Start with DI4		
AO1.GD	Gradient <O.1.4≠0> [0.1 ... 100.0 %]	1.0 %	
AO1.TB	Time base <O.1.4≠0> [s, min, h]	s	
AO1.ST	Initial value <O.1.4≠0> [-10.0 ... 110.0 %]	0.0 %	

O.1	Analog output AO1	Default setting	Setting
O.1.5	Limit output rate <O.1.1≠0, O.1.4-0>	O.1.5-0	
-0	Off		
-1	Increasing, continuously active		
-2	Decreasing, continuously active		
-3	Increasing and decreasing		
-4	Increasing. Start with DI1		
-5	Increasing. Start with DI2		
-6	Increasing. Start with DI3		
-7	Increasing. Start with DI4		
-8	Decreasing. Start with DI1		
-9	Decreasing. Start with DI2		
-10	Decreasing. Start with DI3		
-11	Decreasing. Start with DI4		
AO1.GD1	Gradient for increasing output signal <O.1.5-1/-3/-4/-5/-6/-7>	[0.1 ... 100.0 %]	1.0 %
AO1.GD2	Gradient for decreasing output signal <O.1.5-2/-3/-8/-9/-10/-11>	[0.1 ... 100.0 %]	1.0 %
AO1.TB2	Time base <O.1.5≠0>	[s, min, h]	s
O.1.6	Constant output value 1 with DI (auto mode) <O.1.1≠0>	O.1.6-0	
-0	Off		
-1	With digital input DI1		
-2	With digital input DI2		
-3	With digital input DI3		
-4	With digital input DI4		
AO1.K1	Constant output value 1 <O.1.6≠0>	[-10.0 ... 110.0 %]	0.0 %
O.1.7	Constant output value 2 with DI (man/auto) <O.1.1≠0>	O.1.7-0	
-0	Off		
-1	With digital input DI1		
-2	With digital input DI2		
-3	With digital input DI3		
-4	With digital input DI4		
AO1.K2	Constant output value 2 <O.1.7≠0>	[-10.0 ... 110.0 %]	0.0 %
O.1.8	Limit output by input TR <O.1.1≠0>	O.1.8-0	
-0	Off		
-1	To minimum value		
-2	To maximum value		

Annex A (configuration guide)

O.1	Analog output AO1	Default setting	Setting
O.1.9	Function generation <O.1.1≠0>	0.1.9-0	
-0	Off		
-1	Setting as required		
-2	Equal percentage		
-3	Reverse equal percentage		
AO1.I1	Input value 1 <O.1.9-1>	[-9999.0 ... 9999.0]	0.0
AO1.O1	Output value 1 <O.1.9-1>	[-10.0 ... 110.0 %]	0.0 %
AO1.I2	Input value 2 <O.1.9-1>	[-9999.0 ... 9999.0]	0.0
AO1.O2	Output value 2 <O.1.9-1>	[-10.0 ... 110.0 %]	0.0 %
AO1.I3	Input value 3 <O.1.9-1>	[-9999.0 ... 9999.0]	0.0
AO1.O3	Output value 3 <O.1.9-1>	[-10.0 ... 110.0 %]	0.0 %
AO1.I4	Input value 4 <O.1.9-1>	[-9999.0 ... 9999.0]	0.0
AO1.O4	Output value 4 <O.1.9-1>	[-10.0 ... 110.0 %]	0.0 %
AO1.I5	Input value 5 <O.1.9-1>	[-9999.0 ... 9999.0]	0.0
AO1.O5	Output value 5 <O.1.9-1>	[-10.0 ... 110.0 %]	0.0 %
AO1.I6	Input value 6 <O.1.9-1>	[-9999.0 ... 9999.0]	0.0
AO1.O6	Output value 6 <O.1.9-1>	[-10.0 ... 110.0 %]	0.0 %
AO1.I7	Input value 7 <O.1.9-1>	[-9999.0 ... 9999.0]	100.0
AO1.O7	Output value 7 <O.1.9-1>	[-10.0 ... 110.0 %]	100.0 %
O.2	Analog output AO2	Default setting	Setting
O.2.1	Assign source	0.2.1-0	
-0	Off		
-1	Controller [1] output Y		
-2	Controller [2] output Y <M.1-3/-4/-5/-6>		
-4	Constant positioning value		
-5	[1] Input PV before filter <1C.1.1.1≠0>		
-6	[1] Input PV after function generation <1C.1.1.1≠0>		
-7	[1] Actual value PVO <1C.1.1.1≠0>		
-8	[1] Input SPE before filter <1C.1.2.1≠0>		
-9	[1] Input SPE after function generation <1C.1.2.1≠0>		
-10	[1] Input DV before filter <1C.1.3.1≠0>		
-11	[1] Input DV after function generation <1C.1.3.1≠0>		
-12	[1] Input TR before filter <1C.1.4.1≠0>		
-13	[1] Input TR after function generation <1C.1.4.1≠0>		
-14	[1] Input FB before filter <1C.1.5.1≠0>		
-15	[1] Signal A <1C.3.2.1≠0/1C.3.2.3≠0>		
-16	[1] Signal B <1C.3.2.3≠0>		

O.2	Analog output AO2	Default setting	Setting
-17	[1] Set point SPO		
-18	[1] Error signal +/-e		
-19	[1] Abs. error signal e		
-20	[1] Set point ratio SPR <M.1-2/-6>		
-21	[1] Actual ratio PVR <M.1-2/-6>		
-22	[2] Input PV before filter <M.1-3/-4/-5/-6, 2C.1.1.1≠0>		
-23	[2] Input PV after function generation <M.1-3/-4/-5/-6, 2C.1.1.1≠0>		
-24	[2] Actual value PVO <M.1-3/-4/-5/-6, 2C.1.1.1≠0>		
-25	[2] Input SPE before filter <M.1-3/-4/-5/-6, 2C.1.2.1≠0>		
-26	[2] Input SPE after function generation <M.1-3/-4/-5/-6, 2C.1.2.1≠0>		
-27	[2] Input DV before filter <M.1-3/-4/-5/-6, 2C.1.3.1≠0>		
-28	[2] Input DV after function generation <M.1-3/-4/-5/-6, 2C.1.3.1≠0>		
-29	[2] Input TR before filter <M.1-3/-4/-5/-6, 2C.1.4.1≠0>		
-30	[2] Input TR after function generation <M.1-3/-4/-5/-6, 2C.1.4.1≠0>		
-31	[2] Input FB before filter <M.1-3/-4/-5/-6, 2C.1.5.1≠0>		
-32	[2] Signal A <M.1-3/-4/-5/-6, 2C.3.2.1≠0, 2C.3.2.3≠0>		
-33	[2] Signal B <M.1-3/-4/-5/-6, 2C.3.2.3≠0>		
-34	[2] Set point SPO <M.1-3/-4/-5/-6>		
-35	[2] Error signal +/-e <M.1-3/-4/-5/-6>		
-36	[2] Abs. error signal e <M.1-3/-4/-5/-6>		
-37	Output master controller YM <M.1-3>		
-38	Y1*Y2*AO2.KM/100 <M.1-5/-6>		
-39	(100-Y1)*Y2*AO2.KM/100 <M.1-5/-6>		
AO2.FX	Constant output value <O.2.1-4> [-10.0 ... 110.0 %]	0.0 %	
AO2.KM	Constant, mixing operation <O.2.1-38/-39> [0.0 ... 100.0]	1.0	
O.2.2	Output signal <O.2.1≠0>	O.2.2-1	
-1	4-20 mA		
-2	0-20 mA		
-3	0-10 V		
-4	2-10 V		
AO2.MIN	Minimum output value [-10.0 ... 110.0 %]	0.0 %	
AO2.MAX	Maximum output value [-10.0 ... 110.0 %]	100.0 %	

Annex A (configuration guide)

O.2	Analog output AO2	Default setting	Setting
O.2.3	Operating direction <O.2.1≠0>	O.2.3-1	
-1	Increasing		
-2	Decreasing		
AO2.P1	Y value for AO2=AO2.MIN <O.2.3-1> [-10.0 ... 110.0 %] Y value for AO2=AO2.MAX <O.2.3-2> The default value of AO2.P1 is the same as AO2.MIN. If AO2.MIN is changed, AO2.P1 is set to AO2.MIN.	0.0 %	
AO2.P2	Y value for AO2=AO2.MAX <O.2.3-1> [-10.0 ... 110.0 %] Y value for AO2=AO2.MIN <O.2.3-2> The default value of AO2.P2 is the same as AO2.MIN. If AO2.MAX is changed, AO2.P2 is set to AO2.MAX.	100.0 %	
O.2.4	Output ramp <O.2.1≠0, O.2.5-0>	O.2.4-0	
-0	Off		
-1	Start with DI1		
-2	Start with DI2		
-3	Start with DI3		
-4	Start with DI4		
AO2.GD	Gradient <O.2.4≠0> [0.1 ... 100.0 %]	1.0 %	
AO2.TB	Time base <O.2.4≠0> [s, min, h]	s	
AO2.ST	Initial value <O.2.4≠0> [-10.0 ... 110.0 %]	0.0 %	
O.2.5	Limit output rate <O.2.1≠0, O.2.4-0>	O.2.5-0	
-0	Off		
-1	Increasing, continuously active		
-2	Decreasing, continuously active		
-3	Increasing and decreasing		
-4	Increasing. Start with DI1		
-5	Increasing. Start with DI2		
-6	Increasing. Start with DI3		
-7	Increasing. Start with DI4		
-8	Decreasing. Start with DI1		
-9	Decreasing. Start with DI2		
-10	Decreasing. Start with DI3		
-11	Decreasing. Start with DI4		
AO2.GD1	Gradient for increasing output signal <O.2.5-1/-3/-4/-5/-6/-7> [0.1 ... 100.0 %]	1.0 %	
AO2.GD2	Gradient for decreasing output signal <O.2.5-2/-3/-8/-9/-10/-11> [0.1 ... 100.0 %]	1.0 %	
AO2.TB2	Time base <O.2.5≠0> [s, min, h]	s	

O.2	Analog output AO2	Default setting	Setting
O.2.6	Constant output value 1 with DI (auto mode) <O.2.1≠0>	0.2.6-0	
-0	Off		
-1	With digital input DI1		
-2	With digital input DI2		
-3	With digital input DI3		
-4	With digital input DI4		
AO2.K1	Constant output value 1 <O.2.6≠0> [-10.0 ... 110.0 %]	0.0 %	
O.2.7	Constant output value 2 with DI (man/auto) <O.2.1≠0>	0.2.7-0	
-0	Off		
-1	With digital input DI1		
-2	With digital input DI2		
-3	With digital input DI3		
-4	With digital input DI4		
AO2.K2	Constant output value 2 <O.2.7≠0> [-10.0 ... 110.0 %]	0.0 %	
O.2.8	Limit output by input TR <O.2.1≠0>	0.2.8-0	
-0	Off		
-1	To minimum value		
-2	To maximum value		
O.2.9	Function generation <O.2.1≠0>	0.2.9-0	
-0	Off		
-1	Setting as required		
-2	Equal percentage		
-3	Reverse equal percentage		
AO2.I1	Input value 1 <O.2.9-1> [-9999.0 ... 9999.0]	0.0	
AO2.O1	Output value 1 <O.2.9-1> [-10.0 ... 110.0 %]	0.0 %	
AO2.I2	Input value 2 <O.2.9-1> [-9999.0 ... 9999.0]	0.0	
AO2.O2	Output value 2 <O.2.9-1> [-10.0 ... 110.0 %]	0.0 %	
AO2.I3	Input value 3 <O.2.9-1> [-9999.0 ... 9999.0]	0.0	
AO2.O3	Output value 3 <O.2.9-1> [-10.0 ... 110.0 %]	0.0 %	
AO2.I4	Input value 4 <O.2.9-1> [-9999.0 ... 9999.0]	0.0	
AO2.O4	Output value 4 <O.2.9-1> [-10.0 ... 110.0 %]	0.0 %	
AO2.I5	Input value 5 <O.2.9-1> [-9999.0 ... 9999.0]	0.0	
AO2.O5	Output value 5 <O.2.9-1> [-10.0 ... 110.0 %]	0.0 %	
AO2.I6	Input value 6 <O.2.9-1> [-9999.0 ... 9999.0]	0.0	
AO2.O6	Output value 6 <O.2.9-1> [-10.0 ... 110.0 %]	0.0 %	
AO2.I7	Input value 7 <O.2.9-1> [-9999.0 ... 9999.0]	100.0	
AO2.O7	Output value 7 <O.2.9-1> [-10.0 ... 110.0 %]	100.0 %	

Annex A (configuration guide)

O.3	Analog output AO3	Default setting	Setting
O.3.1 -0 Off -1 Controller [1] output Y -2 Controller [2] output Y <M.1-3/-4/-5/-6> -4 Constant positioning value -5 [1] Input PV before filter <1C.1.1.1≠0> -6 [1] Input PV after function generation <1C.1.1.1≠0> -7 [1] Actual value PVO <1C.1.1.1≠0> -8 [1] Input SPE before filter <1C.1.2.1≠0> -9 [1] Input SPE after function generation <1C.1.2.1≠0> -10 [1] Input DV before filter <1C.1.3.1≠0> -11 [1] Input DV after function generation <1C.1.3.1≠0> -12 [1] Input TR before filter <1C.1.4.1≠0> -13 [1] Input TR after function generation <1C.1.4.1≠0> -14 [1] Input FB before filter <1C.1.5.1≠0> -15 [1] Signal A <1C.3.2.1≠0/1C.3.2.3≠0> -16 [1] Signal B <1C.3.2.3≠0> -17 [1] Set point SPO -18 [1] Error signal +/-e -19 [1] Abs. error signal e -20 [1] Set point ratio SPR <M.1-2/-6> -21 [1] Actual ratio PVR <M.1-2/-6> -22 [2] Input PV before filter <M.1-3/-4/-5/-6, 2C.1.1.1≠0> -23 [2] Input PV after function generation <M.1-3/-4/-5/-6, 2C.1.1.1≠0> -24 [2] Actual value PVO <M.1-3/-4/-5/-6, 2C.1.1.1≠0> -25 [2] Input SPE before filter <M.1-3/-4/-5/-6, 2C.1.2.1≠0> -26 [2] Input SPE after function generation <M.1-3/-4/-5/-6, 2C.1.2.1≠0> -27 [2] Input DV before filter <M.1-3/-4/-5/-6, 2C.1.3.1≠0> -28 [2] Input DV after function generation <M.1-3/-4/-5/-6, 2C.1.3.1≠0> -29 [2] Input TR before filter <M.1-3/-4/-5/-6, 2C.1.4.1≠0> -30 [2] Input TR after function generation <M.1-3/-4/-5/-6, 2C.1.4.1≠0> -31 [2] Input FB before filter <M.1-3/-4/-5/-6, 2C.1.5.1≠0> -32 [2] Signal A <M.1-3/-4/-5/-6, 2C.3.2.1≠0, 2C.3.2.3≠0> -33 [2] Signal B <M.1-3/-4/-5/-6, 2C.3.2.3≠0> -34 [2] Set point SPO <M.1-3/-4/-5/-6> -35 [2] Error signal +/-e <M.1-3/-4/-5/-6> -36 [2] Abs. error signal e <M.1-3/-4/-5/-6>	Assign source	O.3.1-1	

O.3	Analog output AO3	Default setting	Setting
-37	Output master controller YM <M.1-3>		
-38	$Y1*Y2*AO3.KM/100$ <M.1-5/-6>		
-39	$(100-Y1)*Y2*AO3.KM/100$ <M.1-5/-6>		
AO3.FX	Constant output value <O.3.1-4> [-10.0 ... 110.0 %]	0.0 %	
AO3.KM	Constant, mixing operation <O.3.1-38/-39> [0.0 ... 100.0]	1.0	
O.3.2	Output signal <O.3.1≠0>	0.3.2-1	
-1	4-20 mA		
-2	0-20 mA		
-3	0-10 V		
-4	2-10 V		
AO3.MIN	Minimum output value [-10.0 ... 110.0 %]	0.0 %	
AO3.MAX	Maximum output value [-10.0 ... 110.0 %]	100.0 %	
O.3.3	Operating direction <O.3.1≠0>	0.3.3-1	
-1	Increasing		
-2	Decreasing		
AO3.P1	Y value for AO3=AO3.MIN <O.3.3-1> [-10.0 ... 110.0 %] Y value for AO3=AO3.MAX <O.3.3-2> The default value of AO3.P1 is the same as AO3.MIN. If AO3.MIN is changed, AO3.P1 is set to AO3.MIN.	0.0 %	
AO3.P2	Y value for AO3=AO3.MAX <O.3.3-1> [-10.0 ... 110.0 %] Y value for AO3=AO3.MIN <O.3.3-2> The default value of AO3.P2 is the same as AO3.MAX. If AO3.MAX is changed, AO3.P2 is set to AO3.MAX.	100.0 %	
O.3.4	Output ramp <O.3.3-1, O.3.5-0>	0.3.4-0	
-0	Off		
-1	Increasing, start with DI1		
-2	Increasing, start with DI2		
-3	Increasing, start with DI3		
-4	Increasing, start with DI4		
AO3.GD	Gradient <O.3.4≠0> [0.1 ... 100.0 %]	1.0 %	
AO3.TB	Time base <O.3.4≠0> [s, min, h]	s	
AO3.ST	Initial value <O.3.4≠0> [-10.0 ... 110.0 %]	0.0 %	
O.3.5	Limit output rate <O.3.1≠0, O.3.4-0>	0.3.5-0	
-0	Off		
-1	Increasing, continuously active		
-2	Decreasing, continuously active		
-3	Increasing and decreasing		
-4	Increasing. Start with DI1		

Annex A (configuration guide)

O.3	Analog output AO3	Default setting	Setting
-5	Increasing. Start with DI2		
-6	Increasing. Start with DI3		
-7	Increasing. Start with DI4		
-8	Decreasing. Start with DI1		
-9	Decreasing. Start with DI2		
-10	Decreasing. Start with DI3		
-11	Decreasing. Start with DI4		
AO3.GD1	Gradient for increasing output signal <0.3.5-1/-3/-4/-5/-6/-7> [0.1 ... 100.0 %]	1.0 %	
AO3.GD2	Gradient for decreasing output signal <0.3.5-2/-3/-8/-9/-10/-11> [0.1 ... 100.0 %]	1.0 %	
AO3.TB2	Time base <0.3.5≠0> [s, min, h]	s	
O.3.6	Constant output value 1 with DI (auto mode) <0.3.1≠0>	0.3.6-0	
-0	Off		
-1	With digital input DI1		
-2	With digital input DI2		
-3	With digital input DI3		
-4	With digital input DI4		
AO3.K1	Constant output value 1 <0.3.6≠0> [-10.0 ... 110.0 %]	0.0 %	
O.3.7	Constant output value 2 with DI (man/auto) <0.3.1≠0>	0.3.7-0	
-0	Off		
-1	With digital input DI1		
-2	With digital input DI2		
-3	With digital input DI3		
-4	With digital input DI4		
AO3.K2	Constant output value 2 <0.3.7≠0> [-10.0 ... 110.0 %]	0.0 %	
O.3.8	Limit output by input TR <0.3.1≠0>	0.3.8-0	
-0	Off		
-1	To minimum value		
-2	To maximum value		
O.3.9	Function generation <0.3.1≠0>	0.3.9-0	
-0	Off		
-1	Setting as required		
-2	Equal percentage		
-3	Reverse equal percentage		
AO3.I1	Input value 1 <0.3.9-1> [-9999.0 ... 9999.0]	0.0	
AO3.O1	Output value 1 <0.3.9-1> [-10.0 ... 110.0 %]	0.0 %	
AO3.I2	Input value 2 <0.3.9-1> [-9999.0 ... 9999.0]	0.0	
AO3.O2	Output value 2 <0.3.9-1> [-10.0 ... 110.0 %]	0.0 %	

O.3	Analog output AO3		Default setting	Setting
AO3.I3	Input value 3 <O.3.9-1>	[-9999.0 ... 9999.0]	0.0	
AO3.O3	Output value 3 <O.3.9-1>	[-10.0 ... 110.0 %]	0.0 %	
AO3.I4	Input value 4 <O.3.9-1>	[-9999.0 ... 9999.0]	0.0	
AO3.O4	Output value 4 <O.3.9-1>	[-10.0 ... 110.0 %]	0.0 %	
AO3.I5	Input value 5 <O.3.9-1>	[-9999.0 ... 9999.0]	0.0	
AO3.O5	Output value 5 <O.3.9-1>	[-10.0 ... 110.0 %]	0.0 %	
AO3.I6	Input value 6 <O.3.9-1>	[-9999.0 ... 9999.0]	0.0	
AO3.O6	Output value 6 <O.3.9-1>	[-10.0 ... 110.0 %]	0.0 %	
AO3.I7	Input value 7 <O.3.9-1>	[-9999.0 ... 9999.0]	100.0	
AO3.O7	Output value 7 <O.3.9-1>	[-10.0 ... 110.0 %]	100.0 %	

O.4	Switching output SO1		Default setting	Setting
O.4.1	Assign source		0.4.1-0	
-0	Off			
-1	Controller [1] output Y			
-2	Controller [2] output Y <M.1-3/-4/-5/-6>			
-38	Y1*Y2*SO1.KM/100 <M.1-5/-6>			
-39	(100-Y1)*Y2*SO1.KM/100 <M.1-5/-6>			
SO1.KM	Constant, mixing operation <O.4.1-38/-39>	[0.0 ... 100.0]	1.0	
O.4.2	Output signal DO1/DO2 <O.4.1≠0>		0.4.2-0	
-0	Off			
-1	Three-step			
-2	Three-step with external feedback			
-3	On-off PWM "+" display			
-4	On-off PWM "-" display			
-5	Three-step PWM with internal feedback			
-6	Three-step PWM with external feedback			
SO1.TY	Transit time <O.4.2-1/-5>	[10 ... 1000 s]	60 s	
SO1.TZ	Dead band <O.4.2≠0>	[0.1 ... 100.0 %]	2.0 %	
SO1.SW	Increment <O.4.2-1/-2>	[1 ... 4]	1	
SO1.P+	Duty cycle (+) signal <O.4.2-3/-4/-5/-6>	[1.0 ... 1000.0 s]	10.0 s	
SO1.P-	Duty cycle (-) signal <O.4.2-5/-6>	[1.0 ... 1000.0 s]	10.0 s	
SO1.TMIN+	Minimum on-time (+) signal <O.4.2-3/-4/-5/-6>	[0.1 ... 100.0 %]	1.0 %	
SO1.TMIN-	Minimum on-time (-) signal <O.4.2-5/-6>	[0.1 ... 100.0 %]	1.0 %	

Annex A (configuration guide)

0.4	Switching output SO1	Default setting	Setting
SO1.TMAX+	Maximum on-time (+) signal <0.4.2-3/-4/-5/-6> [0.1 ... 100.0 %]		
SO1.TMAX-	Maximum on-time (-) signal <0.4.2-5/-6> [0.1 ... 100.0 %]		
SO1.MIN	Minimum output value <0.4.2≠0> [0.0 ... 100.0 %]	0.0 %	
SO1.MAX	Maximum output value <0.4.2≠0> [0.0 ... 100.0 %]	100.0 %	
0.4.3	Operating direction <0.4.1≠0>	0.4.3-1	
-1	Increasing		
-2	Decreasing		
SO1.P1	Y value for SO1=SO1.MIN <0.4.3-1> [0.0 ... 100.0 %] Y value for SO1=SO1.MAX <0.4.3-2> The default value of SO1.P1 is the same as SO1.MIN. If SO1.MIN is changed, SO1.P1 is set to SO1.MIN.	0.0 %	
SO1.P2	Y value for SO1=SO1.MAX <0.4.3-1> [0.0 ... 100.0 %] Y value for SO1=SO1.MIN <0.4.3-2> The default value of SO1.P2 is the same as SO1.MAX. If SO1.MAX is changed, SO1.P2 is set to SO1.MAX.	100.0 %	
0.4.4	Output ramp <0.4.1≠0>	0.4.4-0	
-0	Off		
-1	Start with DI1		
-2	Start with DI2		
-3	Start with DI3		
-4	Start with DI4		
SO1.GD	Gradient <0.4.4≠0> [0.1 ... 100.0 %]	1.0 %	
SO1.TB	Time base <0.4.4≠0> [s, min, h]	s	
SO1.ST	Initial value <0.4.4≠0> [-10.0 ... 110.0 %]	0.0 %	
0.4.6	Constant output value 1 with DI (auto mode) <0.4.1≠0>	0.4.6-0	
-0	Off		
-1	With digital input DI1		
-2	With digital input DI2		
-3	With digital input DI3		
-4	With digital input DI4		
SO1.K1	Constant output value 1 <0.4.6≠0> [-10.0 ... 110.0 %]	0.0 %	
0.4.7	Constant output value 2 with DI (man/auto) <0.4.1≠0>	0.4.7-0	
-0	Off		
-1	With digital input DI1		
-2	With digital input DI2		
-3	With digital input DI3		

O.4	Switching output SO1	Default setting	Setting
-4	With digital input DI4		
SO1.K2	Constant output value 2 <O.4.7≠0> [-10.0 ... 110.0 %]	0.0 %	
O.4.8	Limit output by input TR <O.4.1≠0>	0.4.8-0	
-0	Off		
-1	To minimum value		
-2	To maximum value		
O.4.9	Function generation <O.4.1≠0>	0.4.9-0	
-0	Off		
-1	Setting as required		
-2	Equal percentage		
-3	Reverse equal percentage		
SO1.I1	Input value 1 <O.4.9-1> [-10.0 ... 110.0 %]	0.0 %	
SO1.O1	Output value 1 <O.4.9-1> [-10.0 ... 110.0 %]	0.0 %	
SO1.I2	Input value 2 <O.4.9-1> [-10.0 ... 110.0 %]	0.0 %	
SO1.O2	Output value 2 <O.4.9-1> [-10.0 ... 110.0 %]	0.0 %	
SO1.I3	Input value 3 <O.4.9-1> [-10.0 ... 110.0 %]	0.0 %	
SO1.O3	Output value 3 <O.4.9-1> [-10.0 ... 110.0 %]	0.0 %	
SO1.I4	Input value 4 <O.4.9-1> [-10.0 ... 110.0 %]	0.0 %	
SO1.O4	Output value 4 <O.4.9-1> [-10.0 ... 110.0 %]	0.0 %	
SO1.I5	Input value 5 <O.4.9-1> [-10.0 ... 110.0 %]	0.0 %	
SO1.O5	Output value 5 <O.4.9-1> [-10.0 ... 110.0 %]	0.0 %	
SO1.I6	Input value 6 <O.4.9-1> [-10.0 ... 110.0 %]	0.0 %	
SO1.O6	Output value 6 <O.4.9-1> [-10.0 ... 110.0 %]	0.0 %	
SO1.I7	Input value 7 <O.4.9-1> [-10.0 ... 110.0 %]	100.0 %	
SO1.O7	Output value 7 <O.4.9-1> [-10.0 ... 110.0 %]	100.0 %	
O.5	Switching output SO2	Default setting	Setting
O.4.1	Assign source	0.5.1-0	
-0	Off		
-1	Controller [1] output Y		
-2	Controller [2] output Y <M.1-3/-4/-5/-6>		
-38	$Y1 * Y2 * SO2.KM/100$ <M.1-5/-6>		
-39	$(100 - Y1) * Y2 * SO2.KM/100$ <M.1-5/-6>		
SO2.KM	Constant, mixing operation <O.5.1-38/-39> [0.0 ... 100.0]	1.0	

Annex A (configuration guide)

O.5	Switching output SO2		Default setting	Setting
O.5.2	Output signal DO3/DO4 <O.5.1≠0>		0.5.2-0	
-0	Off			
-1	Three-step			
-2	Three-step with external feedback			
-3	On-off PWM "+" display			
-4	On-off PWM "-" display			
-5	Three-step PWM with internal feedback			
-6	Three-step PWM with external feedback			
SO2.TY	Transit time <O.5.2-1/-5>	[10 ... 1000 s]	60 s	
SO2.TZ	Dead band <O.5.2≠0>	[0.1 ... 100.0 %]	2.0 %	
SO2.SW	Increment <O.5.2-1/-2>	[1 ... 4]	1	
SO2.P+	Duty cycle (+) signal <O.5.2-3/-4/-5/-6>	[1.0 ... 1000.0 s]	10.0 s	
SO2.P-	Duty cycle (-) signal <O.5.2-5/-6>	[1.0 ... 1000.0 s]	10.0 s	
SO2.TMIN+	Minimum on-time (+) signal <O.5.2-3/-4/-5/-6>	[0.1 ... 100.0 %]	1.0 %	
SO2.TMIN-	Minimum on-time (-) signal <O.5.2-5/-6>	[0.1 ... 100.0 %]	1.0 %	
SO2.TMAX+	Maximum on-time (+) signal <O.5.2-3/-4/-5/-6>	[0.1 ... 100.0 %]		
SO2.TMAX-	Maximum on-time (-) signal <O.5.2-5/-6>	[0.1 ... 100.0 %]		
SO2.MIN	Minimum output value <O.5.2≠0>	[0.0 ... 100.0 %]	0.0 %	
SO2.MAX	Maximum output value <O.5.2≠0>	[0.0 ... 100.0 %]	100.0 %	
O.5.3	Operating direction <O.5.1≠0>		0.5.3-1	
-1	Increasing			
-2	Decreasing			
SO2.P1	Y value for SO2=SO2.MIN <O.5.3-1> Y value for SO2=SO2.MAX <O.5.3-2> The default value of SO2.P1 is the same as SO2.MIN. If SO2.MIN is changed, SO2.P1 is set to SO2.MIN.	[0.0 ... 100.0 %]	0.0 %	
SO2.P2	Y value for SO2=SO2.MAX <O.5.3-1> Y value for SO2=SO2.MIN <O.5.3-2> The default value of SO2.P2 is the same as SO2.MAX. If SO2.MAX is changed, SO2.P2 is set to SO2.MAX.	[0.0 ... 100.0 %]	100.0 %	

0.5	Switching output SO2	Default setting	Setting
0.5.4	Output ramp <0.5.1≠0>	0.5.4-0	
-0	Off		
-1	Start with DI1		
-2	Start with DI2		
-3	Start with DI3		
-4	Start with DI4		
SO2.GD	Gradient <0.5.4≠0> [0.1 ... 100.0 %]	1.0 %	
SO2.TB	Time base <0.5.4≠0> [s, min, h]	s	
SO2.ST	Initial value <0.5.4≠0> [-10.0 ... 110.0 %]	0.0 %	
0.5.6	Constant output value 1 with DI (auto mode) <0.5.1≠0>	0.5.6-0	
-0	Off		
-1	With digital input DI1		
-2	With digital input DI2		
-3	With digital input DI3		
-4	With digital input DI4		
SO2.K1	Constant output value 1 <0.5.6≠0> [-10.0 ... 110.0 %]	0.0 %	
0.5.7	Constant output value 2 with DI (man/auto) <0.5.1≠0>	0.5.7-0	
-0	Off		
-1	With digital input DI1		
-2	With digital input DI2		
-3	With digital input DI3		
-4	With digital input DI4		
SO2.K2	Constant output value 2 <0.5.7≠0> [-10.0 ... 110.0 %]	0.0 %	
0.5.8	Limit output by input TR <0.5.1≠0>	0.5.8-0	
-0	Off		
-1	To minimum value		
-2	To maximum value		
0.5.9	Function generation <0.5.1≠0>	0.5.9-0	
-0	Off		
-1	Setting as required		
-2	Equal percentage		
-3	Reverse equal percentage		
SO2.I1	Input value 1 <0.5.9-1> [-10.0 ... 110.0 %]	0.0 %	
SO2.O1	Output value 1 <0.5.9-1> [-10.0 ... 110.0 %]	0.0 %	
SO2.I2	Input value 2 <0.5.9-1> [-10.0 ... 110.0 %]	0.0 %	
SO2.O2	Output value 2 <0.5.9-1> [-10.0 ... 110.0 %]	0.0 %	
SO2.I3	Input value 3 <0.5.9-1> [-10.0 ... 110.0 %]	0.0 %	
SO2.O3	Output value 3 <0.5.9-1> [-10.0 ... 110.0 %]	0.0 %	

Annex A (configuration guide)

O.5	Switching output SO2	Default setting	Setting
SO2.I4	Input value 4 <0.5.9-1> [-10.0 ... 110.0 %]	0.0 %	
SO2.O4	Output value 4 <0.5.9-1> [-10.0 ... 110.0 %]	0.0 %	
SO2.I5	Input value 5 <0.5.9-1> [-10.0 ... 110.0 %]	0.0 %	
SO2.O5	Output value 5 <0.5.9-1> [-10.0 ... 110.0 %]	0.0 %	
SO2.I6	Input value 6 <0.5.9-1> [-10.0 ... 110.0 %]	0.0 %	
SO2.O6	Output value 6 <0.5.9-1> [-10.0 ... 110.0 %]	0.0 %	
SO2.I7	Input value 7 <0.5.9-1> [-10.0 ... 110.0 %]	100.0 %	
SO2.O7	Output value 7 <0.5.9-1> [-10.0 ... 110.0 %]	100.0 %	

O.6	Digital output DO1 <0.4.2-0>	Default setting	Setting
O.6.1	Assign function	0.6.1-0	
-0	Off		
-1	Limit relay Controller [1]		
-2	Limit relay Controller [2] <M.1-3/-4/-5/-6>		
-3	With digital input DI1		
-4	With digital input DI2		
-5	With digital input DI3		
-6	With digital input DI4		
-7	With digital output DO5 <0.10.1≥5>		
-8	With digital output DO6 <0.11.1≥5>		
O.6.2	Assign signal <0.6.1≠0>	0.6.2-0	
-0	Off		
-1	Input PV <C.1.1.1≠0>		
-2	Input SPE <C.1.2.1≠0>		
-3	Input DV <C.1.3.1≠0>		
-4	Input TR <C.1.4.1≠0>		
-5	Input FB <C.1.5.1≠0>		
-6	Actual value PV0 <C.1.1.1≠0>		
-7	Difference PV – SPE <C.1.1.1≠0, C.1.2.1≠0>		
-8	Difference PV – DV <C.1.1.1≠0, C.1.3.1≠0>		
-9	Difference SPE – DV <C.1.2.1≠0, C.1.3.1≠0>		
-10	Error signal e		
-11	Abs. error signal e		
-12	Output AO1 <0.1.1≠0>		
-13	Output AO2 <0.2.1≠0>		
-14	Output AO3 <0.3.1≠0>		
-15	Output SO1 <0.4.1≠0>		

O.6	Digital output DO1 <O.4.2-0>	Default setting	Setting
-16	Output SO2 <O.5.1≠0>		
-17	Actual ratio PVR <M.1-2/-6 Controller [1], O.6.1-1>		
-18	Difference PV[1] – PV[2] <M.1-3/-4/-5/-6, C.1.1.1≠0, O.6.1-1/-2>		
O.6.3	Switching function <O.6.2≠0>	0.6.3-0	
-0	Off		
-1	Signal under limit		
-2	Signal above limit		
DO1.LIM	Limit <O.6.3≠0>	0.00	
	<O.6.2-1/-2/-3/-4/-5/-6/-17>: [-999.00 ... 9999.00]		
	<O.6.2-7/-8/-9/-18>: [-9999.00 ... 9999.00]		
	<O.6.2-10>: [-110.00 ... 110.00 %]		
	<O.6.2-11>: [0.00 ... 110.00 %]		
	<O.6.2-12/-13/-14/-15/-16>: [-10.00 ... 110.00 %]		
DO1.HYS	Hysteresis	[0.00 ... 9999.00]	0.50
	<O.6.2-10/-11/-12/-13/-14/-15/-16>: [0.00 ... 110.00 %]		
O.6.4	Inverting <O.6.1≠0>	0.6.4-0	
-0	Off		
-1	On		
O.6.5	Storage <O.6.1≠0>	0.6.5-0	
-0	Off		
-1	Reset with DI1		
-2	Reset with DI2		
-3	Reset with DI3		
-4	Reset with DI4		
O.7	Digital output DO2 <O.4.2-0>	Default setting	Setting
O.7.1	Assign function	0.7.1-0	
-0	Off		
-1	Limit relay Controller [1]		
-2	Limit relay Controller [2] <M.1-3/-4/-5/-6>		
-3	With digital input DI1		
-4	With digital input DI2		
-5	With digital input DI3		
-6	With digital input DI4		
-7	With digital output DO5 <O.10.1≥5>		
-8	With digital output DO6 <O.11.1≥5>		

O.7	Digital output DO2 <O.4.2-0>	Default setting	Setting
O.7.5 -0 Off -1 Reset with DI1 -2 Reset with DI2 -3 Reset with DI3 -4 Reset with DI4	Storage <O.7.1≠0>	0.7.5-0	
O.8	Digital output DO3 <O.5.2-0>	Default setting	Setting
O.8.1 -0 Off -1 Limit relay Controller [1] -2 Limit relay Controller [2] <M.1-3/-4/-5/-6> -3 With digital input DI1 -4 With digital input DI2 -5 With digital input DI3	Assign function	0.8.1-0	
-6 With digital input DI4 -7 With digital output DO5 <O.10.1≥5> -8 With digital output DO6 <O.11.1≥5>			
O.8.2 -0 Off -1 Input PV <C.1.1.1≠0> -2 Input SPE <C.1.2.1≠0> -3 Input DV <C.1.3.1≠0> -4 Input TR <C.1.4.1≠0> -5 Input FB <C.1.5.1≠0> -6 Actual value PVO <C.1.1.1≠0> -7 Difference PV – SPE <C.1.1.1≠0, C.1.2.1≠0> -8 Difference PV – DV <C.1.1.1≠0, C.1.3.1≠0> -9 Difference SPE – DV <C.1.2.1≠0, C.1.3.1≠0> -10 Error signal e -11 Abs. error signal e -12 Output AO1 <O.1.1≠0> -13 Output AO2 <O.2.1≠0> -14 Output AO3 <O.3.1≠0> -15 Output SO1 <O.4.1≠0> -16 Output SO2 <O.5.1≠0> -17 Actual ratio PVR <M.1-2/-6 Controller [1], O.8.1-1/-2> -18 Difference PV[1] – PV[2] <M.1-3/-4/-5/-6, C.1.1.1≠0, O.8.1-1/-2>	Assign signal <O.8.1≠0>	0.8.2-0	

Annex A (configuration guide)

O.8	Digital output DO3 <O.5.2-0>	Default setting	Setting
O.8.3	Switching function <O.8.2≠0>	0.8.3-0	
-0	Off		
-1	Signal under limit		
-2	Signal above limit		
DO3.LIM	Limit <O.8.3≠0> <O.8.2-1/-2/-3/-4/-5/-6/-17>: [-999.00 ... 9999.00] <O.8.2-7/-8/-9/-18>: [-9999.00 ... 99999.00] <O.8.2-10>: [-110.00 ... 110.00 %] <O.8.2-11>: [0.00 ... 110.00 %] <O.8.2-12/-13/-14/-15/-16>: [-10.00 ... 110.00 %]	0.00	
DO3.HYS	Hysteresis <O.8.2-10/-11/-12/-13/-14/-15/-16>: [0.00 ... 110.00 %]	[0.00 ... 9999.00] [0.00 ... 110.00 %]	0.50
O.8.4	Inverting <O.8.1≠0>	0.8.4-0	
-0	Off		
-1	On		
O.8.5	Storage <O.8.1≠0>	0.8.5-0	
-0	Off		
-1	Reset with DI1		
-2	Reset with DI2		
-3	Reset with DI3		
-4	Reset with DI4		
O.9	Digital output DO4 <O.5.2-0>	Default setting	Setting
O.9.1	Assign function	0.9.1-0	
-0	Off		
-1	Limit relay Controller [1]		
-2	Limit relay Controller [2] <M.1-3/-4/-5/-6>		
-3	With digital input DI1		
-4	With digital input DI2		
-5	With digital input DI3		
-6	With digital input DI4		
-7	With digital output DO5 <O.10.1≥5>		
-8	With digital output DO6 <O.11.1≥5>		
O.9.2	Assign signal <O.9.1≠0>	0.9.2-0	
-0	Off		
-1	Input PV <C.1.1.1≠0>		
-2	Input SPE <C.1.2.1≠0>		
-3	Input DV <C.1.3.1≠0>		

O.9	Digital output DO4 <O.5.2-0>	Default setting	Setting
-4 -5 -6 -7 -8 -9 -10 -11 -12 -13 -14 -15 -16 -17 -18	Input TR <C.1.4.1≠0> Input FB <C.1.5.1≠0> Actual value PV0 <C.1.1.1≠0> Difference PV – SPE <C.1.1.1≠0, C.1.2.1≠0> Difference PV – DV <C.1.1.1≠0, C.1.3.1≠0> Difference SPE – DV <C.1.2.1≠0, C.1.3.1≠0> Error signal e Abs. error signal e Output AO1 <O.1.1≠0> Output AO2 <O.2.1≠0> Output AO3 <O.3.1≠0> Output SO1 <O.4.1≠0> Output SO2 <O.5.1≠0> Actual ratio PVR <M.1-2/-6 Controller [1], O.9.1-1> Difference PV[1] – PV[2] <M.1-3/-4/-5/-6, C.1.1.1≠0, O.9.1-1/-2>		
O.9.3 -0 -1 -2	Switching function <O.9.2≠0> Off Signal under limit Signal above limit	0.9.3-0	
DO4.LIM	Limit <O.9.3≠0> <O.9.2-1/-2/-3/-4/-5/-6/-17>: [-999.00 ... 9999.00] <O.9.2-7/-8/-9/-18>: [-9999.00 ... 9999.00] <O.9.2-10>: [-110.00 ... 110.00 %] <O.9.2-11>: [0.00 ... 110.00 %] <O.9.2-12/-13/-14/-15/-16>: [-10.00 ... 110.00 %]	0.00	
DO4.HYS	Hysteresis [0.00 ... 9999.00] <O.9.2-10/-11/-12/-13/-14/-15/-16>: [0.00 ... 110.00 %]	0.50	
O.9.4 -0 -1	Inverting <O.9.1≠0> Off On	0.9.4-0	
O.9.5 -0 -1 -2 -3 -4	Storage <O.9.1≠0> Off Reset with DI1 Reset with DI2 Reset with DI3 Reset with DI4	0.9.5-0	

Annex A (configuration guide)

O.10	Digital output DO5	Default setting	Setting
O.10.1	Assign function	O.10.1.1-0	
-0	Off		
-1	Digital input DI1 active		
-2	Digital input DI2 active		
-3	Digital input DI3 active		
-4	Digital input DI4 active		
-5	Sensor/signal error <I.1.5≠0/I.2.5≠0/I.3.5≠0/I.4.5≠0>		
-6	Communication failure <D.1.1-1>		
-7	Cascade opened <M.1-3>		
-8	[1] Automatic mode		
-9	[1] Manual mode		
-10	[1] External set point active <1C.2.1.2≠0>		
-11	[1] External output value active <1C.3.3.3≠0>		
-12	[2] Automatic mode <M.1-3/-4/-5/-6>		
-13	[2] Manual mode <M.1-3/-4/-5/-6>		
-14	[2] External set point active <M.1-3/-4/-5/-6, 2C.2.1.2≠0>		
-15	[2] External output value active <M.1-3/-4/-5/-6, 2C.3.3.3≠0>		
-16	Three-step SO1+ instead of DO1 <0.4.1-1/-2/-5/-6>		
-17	Three-step SO2+ instead of DO3 <0.5.1-1/-2/-5/-6>		
-18	On-off SO1+ instead of DO1 <0.4.1-3/-4>		
O.10.2	Inverting	O.10.2-0	
-0	Off		
-1	On		
O.11	Digital output DO6		
O.11.1	Assign function	O.11.1.1-0	
-0	Off		
-1	Digital input DI1 active		
-2	Digital input DI2 active		
-3	Digital input DI3 active		
-4	Digital input DI4 active		
-5	Sensor/signal error <I.1.5≠0/I.2.5≠0/I.3.5≠0/I.4.5≠0>		
-6	Communication failure <D.1.1-1>		
-7	Cascade opened <M.1-3>		
-8	[1] Automatic mode		

O.11	Digital output DO6	Default setting	Setting
-9 -10 -11 -12 -13 -14 -15 -16 -17 -18	[1] Manual mode [1] External set point active <1C.2.1.2≠0> [1] External output value active <1C.3.3.3≠0> [2] Automatic mode <M.1-3/-4/-5/-6> [2] Manual mode <M.1-3/-4/-5/-6> [2] External set point active <M.1-3/-4/-5/-6, 2C.2.1.2≠0> [2] External output value active <M.1-3/-4/-5/-6, 2C.3.3.3≠0> Three-step SO1- instead of DO2 <O.4.1-1/-2/-5/-6> Three-step SO2- instead of DO4 <O.5.1-1/-2/-5/-6> On-off SO1+ instead of DO3 <O.4.1-3/-4>		
O.11.2 -0 -1	Inverting Off On	0.11.2-0	
O.12	Digital output DO7	Default setting	Setting
O.12.2 -0 -1	Inverting Off On	0.12.2.-0	

D Communication

NOTICE

No function due to missing interface board.

The settings of D.2.1 and D.3.1 configuration items are only effective with the corresponding interface board.

➔ Select the interface board (see the 'Operation' section).

D.1	General settings	Default setting	Setting
D1.1	Communication monitoring	D.1.1-0	
-0	Off		
-1	On		
QRY.TOUT	Query timeout <D.1.1-1>	[1 ... 9999 s]	60 s

D.2	RS-232 interface	Default setting	Setting
D.2.1	Protocol	D.2.1-1	
-0	Off		
-1	Automatic (9600, 8, N, 1)		
-2	SSP (9600, 8, N, 1)		
-3	Modbus RTU		
STN	Station number <D.2.1.-3>	[1 ... 255]	1
BITRATE	Transmission rate <D.2.1-3>	[300, 600, 1200, 2400, 4800, 9600, 19200, 38400, 57600, 115200 bit/s]	9600 bit/s
PARITY	Parity <D.2.1-3>	[0 = none, 1 = even, 2 = odd]	0
STOPBIT	Stop bit <D.2.1-3>	1, 2	1
RSP.TOUT	Response timeout <D.2.1-3>	0.1 ... 100.0 s	10.0 s

D.3	RS-485 interface	Default setting	Setting
D.3.1	Protocol	D.3.1-1	
-0	Off		
-1	Automatic (9600, 8, N, 1)		
-2	SSP (9600, 8, N, 1)		
-3	Modbus RTU		
STN	Station number <D.3.1.-3>	[1 ... 255]	1

D.3	RS-485 interface		Default setting	Setting
BITRATE	Transmission rate <D.3.1-3>	[300, 600, 1200, 2400, 4800, 9600, 19200, 38400, 57600, 115200 bit/s]	9600 bit/s	
PARITY	Parity <D.3.1-3>	[0 = none, 1 = even, 2 = odd]	0	
STOPBIT	Stop bit <D.3.1-3>	1, 2	1	
RSP.TOUT	Response timeout <D.3.1-3>	0.1 ... 100.0 s	10.0 s	

A General settings

A.1	Sprache/Language		Default setting	Setting
A.1.1	Auswahl/Selection			
	-1	German		
	-2	English		
	-3	Français		

A.2	Status reading		Default setting	Setting
A.2.1	Left display		A.2.1-1	
	-0	Off <A.2.2≠0>		
	-1	Controller [1]		
	-2	Controller [1] additional display		
	-3	Controller [2] <M.1-3/-4/-5/-6>		
	-4	Controller [2] additional display <M.1-3/-4/-5/-6>		
A.2.2	Right display		A.2.2-0	
	-0	Off <A.2.1≠0>		
	-1	Controller [1]		
	-2	Controller [1] additional display		
	-3	Controller [2] <M.1-3/-4/-5/-6>		
	-4	Controller [2] additional display <M.1-3/-4/-5/-6>		
A.2.3	Contrast			
CTRST	Contrast	[0 ... 100]	50	

Annex A (configuration guide)

A.3	Operating keys	Default setting	Setting
A.3.1	Lock all keys	A.3.1-0	
-0	Off		
-1	With digital input DI1		
-2	With digital input DI2		
-3	With digital input DI3		
-4	With digital input DI4		
A.3.2	Manual/automatic dialog	A.3.2-0	
-0	Off		
-1	On		
A.4	Key number	Default setting	Setting
A.4.1	Key number operation	A.4.1-0	
-0	Off		
-1	On		
CODE	Key number <A.4.1-1>	[0 ... 9999]	0
A.5	Power line frequency	Default setting	Setting
A.5.1	Ripple filter for AI	A.5.1-1	
-1	50 Hz		
-2	60 Hz		
A.20	User calibration	Default setting	Setting
A.20.1	Analog input AI1		
A.20.1.1	Current zero (4 mA) <I.1.1-1>		
A.20.1.2	Current end (20 mA) <I.1.1-1>		
A.20.1.3	Current zero (0 mA) <I.1.1-2>		
A.20.1.4	Current end (20 mA) <I.1.1-2>		
A.20.1.5	Voltage zero (0 V) <I.1.1-3>		
A.20.1.6	Voltage end (10 V) <I.1.1-3>		
A.20.1.7	Voltage zero (2 V) <I.1.1-4>		
A.20.1.8	Voltage end (10 V) <I.1.1-4>		
A.20.1.9	Pt 100 zero (0 °C) <I.1.1-6>		
A.20.1.10	Pt 100 end (300 °C) <I.1.1-6>		
A.20.1.11	Pt 1000 zero (0 °C) <I.1.1-7>		
A.20.1.12	Pt 1000 end (300 °C) <I.1.1-7>		
A20.2	Analog input AI2		
A.20.2.1	Current zero (4 mA) <I.2.1-1>		

A.20	User calibration	Default setting	Setting
A.20.2.2	Current end (20 mA) <I.2.1-1>		
A.20.2.3	Current zero (0 mA) <I.2.1-2>		
A.20.2.4	Current end (20 mA) <I.2.1-2>		
A.20.2.5	Voltage zero (0 V) <I.2.1-3>		
A.20.2.6	Voltage end (10 V) <I.2.1-3>		
A.20.2.7	Voltage zero (2 V) <I.2.1-4>		
A.20.2.8	Voltage end (10 V) <I.2.1-4>		
A.20.2.9	Pt 100 zero (0 °C) <I.2.1-6>		
A.20.2.10	Pt 100 end (300 °C) <I.2.1-6>		
A.20.2.11	Pt 1000 zero (0 °C) <I.2.1-7>		
A.20.2.12	Pt 1000 end (300 °C) <I.2.1-7>		
A.20.2.13	Potentiometer zero <I.2.1-8/-9/-10/-11>		
A.20.2.14	Potentiometer end <I.2.1-8/-9/-10/-11>		
A20.3	Analog input AI3		
A.20.3.1	Current zero (4 mA) <I.3.1-1>		
A.20.3.2	Current end (20 mA) <I.3.1-1>		
A.20.3.3	Current zero (0 mA) <I.3.1-2>		
A.20.3.4	Current end (20 mA) <I.3.1-2>		
A.20.3.5	Voltage zero (0 V) <I.3.1-3>		
A.20.3.6	Voltage end (10 V) <I.3.1-3>		
A.20.3.7	Voltage zero (2 V) <I.3.1-4>		
A.20.3.8	Voltage end (10 V) <I.3.1-4>		
A.20.3.9	Pt 100 zero (0 °C) <I.3.1-6>		
A.20.3.10	Pt 100 end (300 °C) <I.3.1-6>		
A.20.3.11	Pt 1000 zero (0 °C) <I.3.1-7>		
A.20.3.12	Pt 1000 end (300 °C) <I.3.1-7>		
A20.4	Analog input AI4		
A.20.4.1	Current zero (4 mA) <I.4.1-1>		
A.20.4.2	Current end (20 mA) <I.4.1-1>		
A.20.4.3	Current zero (0 mA) <I.4.1-2>		
A.20.4.4	Current end (20 mA) <I.4.1-2>		
A.20.4.5	Voltage zero (0 V) <I.4.1-3>		
A.20.4.6	Voltage end (10 V) <I.4.1-3>		
A.20.4.7	Voltage zero (2 V) <I.4.1-4>		
A.20.4.8	Voltage end (10 V) <I.4.1-4>		
A.20.4.9	Pt 100 zero (0 °C) <I.4.1-6>		
A.20.4.10	Pt 100 end (300 °C) <I.4.1-6>		
A.20.4.11	Pt 1000 zero (0 °C) <I.4.1-7>		
A.20.4.12	Pt 1000 end (300 °C) <I.4.1-7>		

Annex A (configuration guide)

A.20	User calibration	Default setting	Setting
A20.5	Analog output AO1		
A.20.5.1	Current zero (0 mA) <0.1.2-2> · (4 mA) <0.1.2-1>		
A.20.5.2	Current end (20 mA) <0.1.2-1/-2>		
A.20.5.3	Voltage zero (0 V) <0.1.2-3> · (2 V) <0.1.2-4>		
A.20.5.4	Voltage end (10 V) <0.1.2-3/-4>		
A20.6	Analog output AO2		
A.20.6.1	Current zero (0 mA) <0.2.2-2> · (4 mA) <0.2.2-1>		
A.20.6.2	Current end (20 mA) <0.2.2-1/-2>		
A.20.6.3	Voltage zero (0 V) <0.2.2-3> · (2 V) <0.2.2-4>		
A.20.6.4	Voltage end (10 V) <0.2.2-3/-4>		
A20.7	Analog output AO3		
A.20.7.1	Current zero (0 mA) <0.3.2-2> · (4 mA) <0.3.2-1>		
A.20.7.2	Current end (20 mA) <0.3.2-1/-2>		
A.20.7.3	Voltage zero (0 V) <0.3.2-3> · (2 V) <0.3.2-4>		
A.20.7.4	Voltage end (10 V) <0.3.2-3/-4>		
A.21	Default setting		
A.21.1	Reset controller	A.21.1-0	
	-0 Off		
	-1 All except calibration		
	-2 Only user calibration		

17 Annex B

17.1 Accessories

Infrared adapter (RS-232)	Order no. 8864-0900
Fixture for infrared adapter	Order no. 1400-9769
USB to RS232 adapter	Order no. 8812-2001
Driver for USB to RS-232 adapter	▶ www.samsongroup.com > SERVICE & SUPPORT > Download > TROVIS-VIEW > USB/RS-232 adapter (8812-2001)
TROVIS-VIEW software (free of charge)	▶ www.samsongroup.com > SERVICE & SUPPORT > Downloads > TROVIS-VIEW
RS-232/USB interface board	Order no. 1400-9917
RS-485/USB interface board	Order no. 1400-9918
USB cable (2 m) with type A and 5-pin mini-B connectors	Order no. 8801-7301
Connecting cable RJ-12/D-sub, 9 pin (RS-232)	Order no. 1400-7699
Memory pen-64, RJ-12 connector (1170-3163)	Order no. 1400-9753
Modular adapter D-sub 9-pin/RJ-12 for memory pen-64	Order no. 1400-7698
Hardware package consisting of memory pen-64, modular adapter and connecting cable	Order no. 1400-9998

17.2 After-sales service

Contact SAMSON's After-sales Service for support concerning service or repair work or when malfunctions or errors arise.

E-mail contact

You can reach our after-sales service at aftersalesservice@samsongroup.com.

Addresses of SAMSON AG and its subsidiaries

The addresses of SAMSON, its subsidiaries, representatives and service facilities worldwide can be found on our website (▶ www.samsongroup.com) or in all SAMSON product catalogs.

Required specifications

Please submit the following details:

- Model number
- Configuration ID
- Serial number
- Firmware version

EB 6495-2 EN



SAMSON AKTIENGESELLSCHAFT
Weismüllerstraße 3 · 60314 Frankfurt am Main, Germany
Phone: +49 69 4009-0 · Fax: +49 69 4009-1507
samson@samsongroup.com · www.samsongroup.com