

T 3003 EN

Series 42 Self-operated Regulators · Type 42-24 and Type 42-28 Differential Pressure Regulators

With Type 2424/Type 2428 Actuator (closing) and balanced Type 2422 Valve



Application

Differential pressure regulators for district heating systems, extended heating systems and industrial applications

Differential pressure set points Δp from **0.05 to 10 bar** · Valves **DN 15 to 250**¹⁾ · Pressure rating **PN 16 to 40** · Suitable for liquids and vapors²⁾ from **5 to 350 °C** as well as for air and non-flammable gases up to **80 °C**

The valve **closes** when the differential pressure **rises**.

The regulators control the differential pressure according to the adjusted set point.

Special features

- **Type 42-24:** Set point adjustable in wide range
- **Type 42-28:** Fixed set point
- Low-noise, medium-controlled proportional regulator requiring little maintenance
- Suitable for circuit water, water/glycol mixtures, steam and air as well as other liquids, gases and vapors, provided these do not affect the characteristics of the operating diaphragm
- Valve body optionally available in cast iron, spheroidal graphite iron, cast steel, cast stainless steel or forged stainless steel
- Single-seated valve with a plug balanced by a stainless steel bellows or a diaphragm (DN 65 to 250)
- Particularly suitable for district heating supply networks

Versions

Differential pressure regulators for installation in the flow pipe and return flow pipe (see Fig. 5) · Flanged connections

- **Type 42-24** (Fig. 1) · Type 2422 Valve · Balanced by a bellows DN 15 to 250 · Balanced by a diaphragm DN 65 to 250 · Type 2424 Actuator with adjustable set point
- **Type 42-28** (Fig. 2) · Type 2422 Valve · Balanced by a bellows DN 15 to 100 · Balanced by a diaphragm DN 65 to 100 · Type 2428 Actuator with fixed set point, adjusted to $\Delta p = 0.2, 0.3, 0.4$ or 0.5 bar

Accessories

Required accessories, such as compression-type fittings, needle valves, compensation chambers and control lines, are listed in Data Sheet ▶ T 3095.

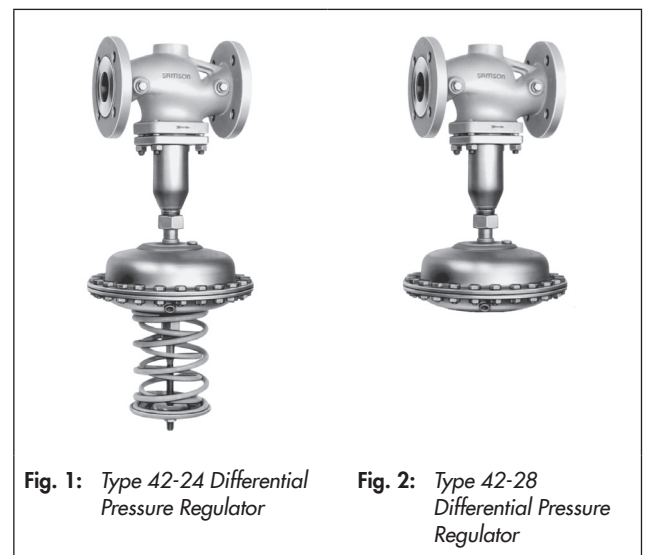

Fig. 1: Type 42-24 Differential Pressure Regulator

Fig. 2: Type 42-28 Differential Pressure Regulator

Special versions

- ANSI and JIS versions on request
- Versions free of non-ferrous metal on request
- Actuator with two diaphragms
- Version for temperatures above 220 °C
- Version for deionized water
- Version for mineral oils which do not affect the characteristics of the FKM diaphragm; other oils on request
- Version for small flow rates · Valve with micro-trim with $K_{VS} 0.001$ to 0.04 or $K_{VS} 0.1, 0.4$ and 1 without pressure balancing
- Type 2422 Valve · DN 15 to 50 without pressure balancing
- Special set point 8 to 16 bar for valves $\leq DN 100$ on request

¹⁾ Valves larger than DN 250 on request

²⁾ Version balanced by a bellows only

Principle of operation (Fig. 3)

The medium flows through the valve in the direction indicated by the arrow. The position of the valve plug (3) determines the differential pressure over the cross-sectional area released between the plug (3) and seat (2).

The Type 2422 Valve is balanced. The forces acting on the valve plug created by the upstream and downstream pressures are balanced by a balancing bellows (5) or balancing diaphragm (5.1). Regulators balanced by a bellows or a diaphragm only differ in the pressure balancing principle applied. Valves balanced by a diaphragm have a balancing diaphragm (5.1) instead of the balancing bellows. The downstream pressure p_2 acts on the bottom of the diaphragm and the upstream pressure p_1 on the top of the diaphragm. As a result, the forces created by the upstream and downstream pressures acting on the plug are balanced out.

The differential pressure to be controlled is transferred to the operating diaphragm (13) where it is transformed into a posi-

tioning force. This force is used to move the plug (3) according to the force of the set point springs (16). The valve begins to close as soon as the differential pressure exceeds the set point.

The set point of Type 42-24 can be adjusted at the set point adjuster (SW 27, 17). In Type 42-28, the set point springs in the actuator determines the set point.

A seal in the actuator separates the pressure in the valve from the pressure in the actuator.

Control lines (20) mounted on site transfer the high pressure (+) and low pressure (-) in both regulator versions.

Type 2424 and Type 2428 Actuators are equipped with an overload protection (21). It prevents a rise in differential pressure during extreme operating conditions (e.g. vacuum at the heat exchanger) by opening an internal excess pressure limiter. As a result, plants and the regulator itself are protected against excessively high differential pressures.

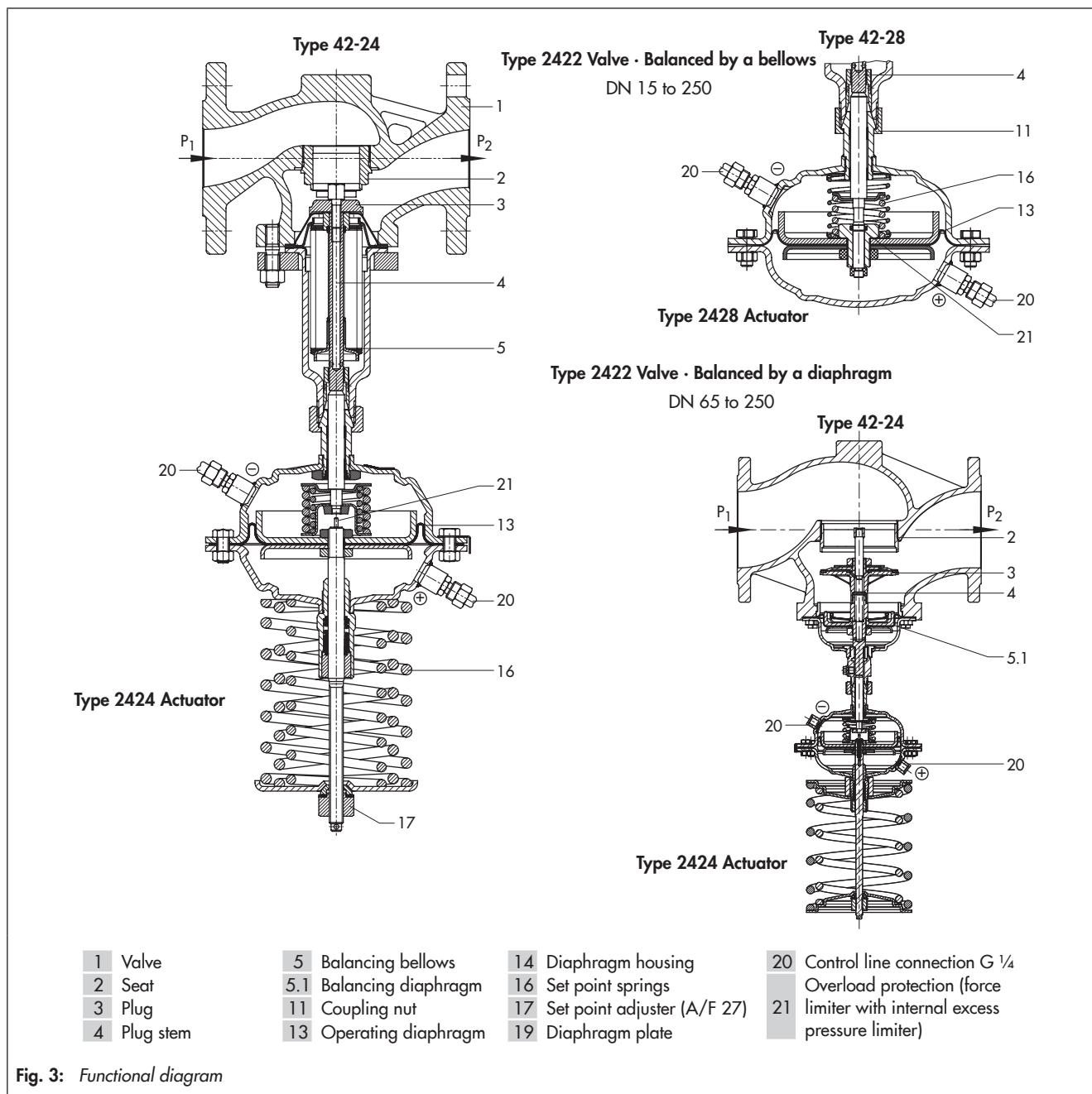

Fig. 3: Functional diagram

Type 42-24 Differential Pressure Regulator with two diaphragms

SAMSON offers a special version of Type 42-24 with an actuator with two diaphragms (see Fig. 4). The actuator with two diaphragms provides increased functional reliability.

An actuator with two diaphragms is always required when an FKM diaphragm is to be used. It is especially suitable for applications with thin oils (e.g. heat transfer oil).

The two diaphragms separate both diaphragm chambers connected to the high-pressure and low-pressure connections. They generate a positioning force from the differential pressure. A mechanical diaphragm rupture indicator (22) is located between the two diaphragms, which responds at approx. 1.5 bar. In the event of a diaphragm rupture, the pressure in the space between the two operating diaphragm starts to increase. This causes the pin in the diaphragm rupture indicator to be pushed outwards and a red ring appears, indicating the diaphragm rupture. The intact operating diaphragm takes on the control task of the ruptured diaphragm.

A pressure switch can be optionally mounted to the actuator to trigger an alarm. We recommend replacing both diaphragms after a diaphragm rupture is indicated.

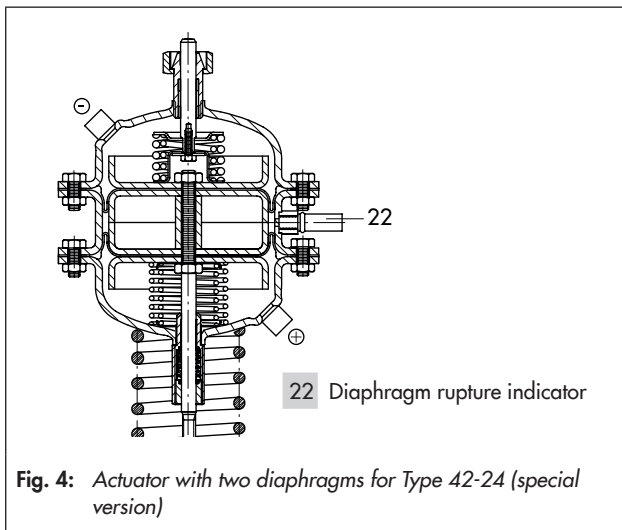

Fig. 4: Actuator with two diaphragms for Type 42-24 (special version)

Installing the valve and mounting the actuator

Valve, actuator and control lines (accessories) are delivered unattached.

A coupling nut is used to attach the actuator to the valve. Preferably mount the actuator after the valve is installed.

The following points must be observed:

- Install the valve in horizontal pipelines.
- The direction of flow must match the direction indicated by the arrow on the body.
- Install a strainer (e.g. SAMSON Type 2 NI) upstream of the valve.

Permissible mounting positions

- Actuator suspended: standard installation, balanced by a bellows or diaphragm, all versions, above 80 °C. Steam control only for version with balanced by a bellows.
- Actuator sideways: versions balanced by a bellows with fixed plug guide or all versions balanced by a diaphragm
- Actuator upright (actuator on top of the valve): all versions balanced by a diaphragm, versions balanced by a bellows DN 15 to 80 and at the same time max. 80 °C

Refer to ► EB 3003 for more details.

Ordering text

Type 42-24 or Type 42-28 Differential Pressure Regulator

Installation in flow pipe/return flow pipe

DN ..., valve balanced by a bellows/diaphragm

PN ..., body material ...

Set point or set point range ... bar

Optionally, accessories ...

Optionally, special version

Application

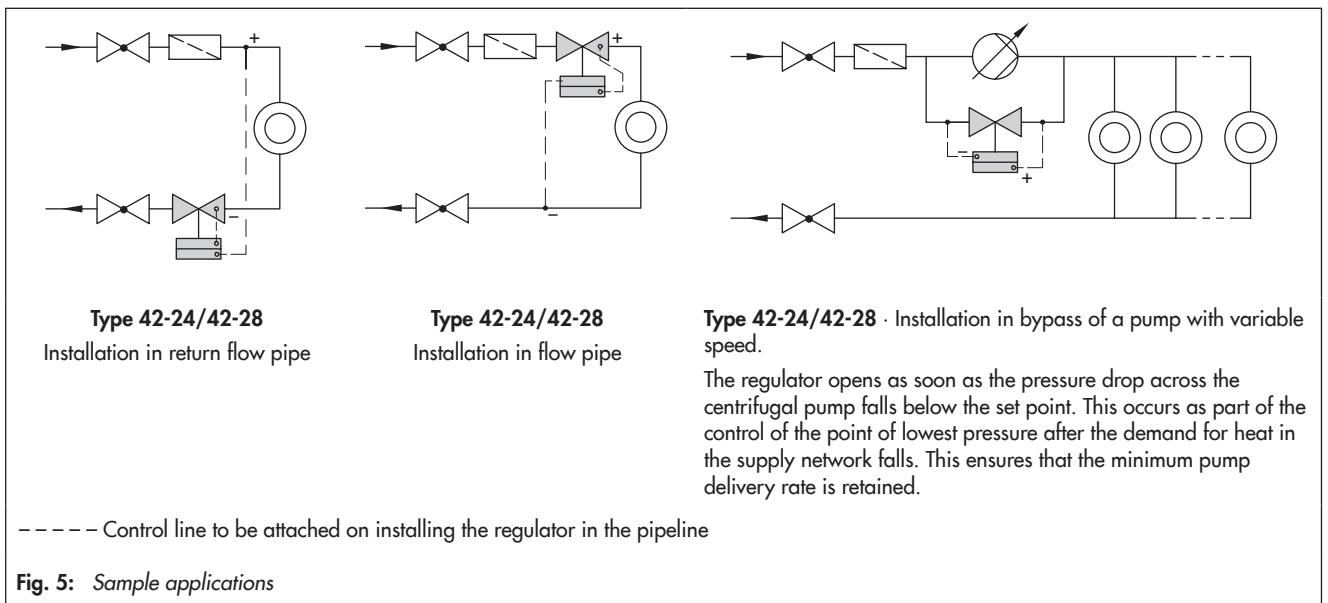

----- Control line to be attached on installing the regulator in the pipeline

Fig. 5: Sample applications

Table 1: Technical data

Type	42-24				42-28	
Nominal size	DN 15 to 250				DN 15 to 100	
Pressure rating	PN 16, 25, 40					
Max. permissible temperature	Valve	See pressure-temperature diagram in ► T 3000				
	Actuator ¹⁾	With compensation chamber: steam and liquids up to 220 °C ²⁾ Without compensation chamber: liquids up to 150 °C, air and gases up to 80 °C				
Set point ranges	0.05 to 0.25 bar · 0.1 to 0.6 bar · 0.2 to 1 bar · 0.5 to 1.5 bar · 1 to 2.5 bar · 2 to 5 bar · 4.5 to 10 bar ³⁾				0.2 bar · 0.3 bar · 0.4 bar · 0.5 bar	
Actuator area A	80 cm ²	160 cm ²	320 cm ²	640 cm ²	160 cm ²	320 cm ²
Pressure above adjusted set point at which internal excess pressure limiter responds	2.4 bar	1.2 bar	0.6 bar	0.3 bar	0.6 bar	0.3 bar
Max. perm. operating pressure for actuator with two diaphragms	40 bar	40 bar	25 bar	25 bar	-	
Conformity	UK · CE · EAC					
Leakage class according to IEC 60534-4	≤0.05 % of K _{V5} coefficient					

¹⁾ Max. 350 °C (660 °F) with extension piece

²⁾ Steam version only with valves balanced by a bellows

³⁾ DN 125 to 250: 4.5 to 10 bar on request

Table 2: Materials · Material numbers according to DIN EN
Table 2.1: Materials for Type 2422 Valve

Type 2422 Valve · Balanced by a bellows						
Nominal size	DN 15 to 250					
Pressure rating	PN 16	PN 25	PN 16, 25 and 40			
Valve body	Cast iron EN-GJL-250	Sph. graphite iron EN-GJS-400-18-LT	Cast steel 1.0619	Cast stainless steel 1.4408	Forged stainless steel 1.4404 ¹⁾	
Valve seat	Stainless steel 1.4104 or 1.4006			1.4404		
Plug	Up to DN 100 ²⁾		Stainless steel 1.4404			
	DN 125 to 250		1.4404, with PTFE soft seal			
Plug stem	1.4301					
Metal bellows	1.4571 · DN 125: 1.4404					
Bottom section	P265GH			1.4571		
Body gasket	Graphite on metal core					
Type 2422 Valve · Balanced by a diaphragm						
Nominal size	DN 65 to 100					
Pressure rating	PN 16	PN 25				
Valve body	Cast iron EN-GJL-250			Spheroidal graphite iron EN-GJS-400-18-LT		
Valve seat	1.4408					
Plug	CW617N					
Diaphragm cases	1.0619					
Pressure balancing	Diaphragm plate 1.4301 · EPDM balancing diaphragm, max. 150 °C or NBR diaphragm, max. 80 °C					
Nominal size	DN 125 to 250					
Pressure rating	PN 16	PN 16/25	PN 16, 25 and 40	-	PN 16, 25 and 40	
Valve body	Cast iron EN-GJL-250	Spheroidal graphite iron EN-GJS-400-18-LT	Cast steel 1.0619	-	Cast stainless steel 1.4408	
Valve seat	CC499K ³⁾					
Plug	CC499K ³⁾ · With EPDM soft seal, max. 150 °C or with PTFE soft seal, max. 150 °C					
Pressure balancing	Diaphragm plate EN-JS1030 · EPDM balancing diaphragm, max. 150 °C or NBR diaphragm, max. 80 °C					

¹⁾ DN 15, 25, 40 and 50 only

²⁾ Optionally with soft seal with standard K_{V5} coefficients

³⁾ Special version 1.4409

Table 2.2: Materials for Type 2424/Type 2428 Actuator

Type 2424/Type 2428 Actuator		
Valve body	Cast iron, spheroidal graphite iron, cast steel 1.0619	Forged steel, cast stainless steel
Diaphragm cases	1.0332	1.4301
Diaphragm	EPDM ¹⁾ with fabric reinforcement	
Guide bushing	DU bushing	PTFE
Seals	EPDM/PTFE ¹⁾	

¹⁾ Special version, e.g. for mineral oils: FKM using an actuator with two diaphragms

Table 3: K_{VS} coefficients, x_{FZ} values and max. permissible differential pressures Δp

Terms for control valve sizing according to IEC 60534, Parts 2-1 and 2-2: $F_L = 0.95$, $X_T = 0.75$

Type 2422 Valve - Unbalanced							
Nominal size	DN	15	20	25	32	40	50
Valve travel		10 mm					
K_{VS} coefficient		4.0	4.0 · 6.3	4.0 · 6.3 · 8.0	16	20	32
Max. perm. differential pressure Δp		14 bar			6 bar		4 bar
x_{FZ} value		0.65	0.6	0.55		0.45	0.4
Reduced K_{VS} coefficient		0.1 · 0.4 · 1.0 · 2.5 or 0.001 to 0.04 (micro trim)				-	
Max. perm. differential pressure Δp		25 bar				-	
x_{FZ} value		0.65				-	

Type 2422 Valve - Balanced by a bellows														
Nominal size	DN	15	20	25	32	40	50	65	80	100	125	150	200	250
Valve travel		10 mm					16 mm			22 mm				
Standard K_{VS} coefficient		4.0	6.3	8.0	16	20	32	50	80	125	190	280	420	500
Max. perm. differential pressure Δp		25 bar					20 bar			16 bar		12 bar	10 bar	
Reduced K_{VS} coefficient		-	4.0	6.3	8.0	16	32		80	80	125	280		
Max. perm. differential pressure Δp		25 bar								20 bar		16 bar	12 bar	
x_{FZ} value		0.65	0.6	0.55		0.45	0.4	0.35				0.3		

Type 2422 Valve - Balanced by a diaphragm									
Nominal size	DN	65	80	100	125	150	200	250	
Valve travel		15 mm			35 mm				
K_{VS} coefficient		50	80	125	250	380	650	800	
Max. perm. differential pressure Δp		10 bar			12 bar		10 bar		
x_{FZ} value		0.4	0.35				0.3		

Dimensional drawings for Type 42-24 and Type 42-28 balanced by a bellows · Dimensions and weights (see Table 4)

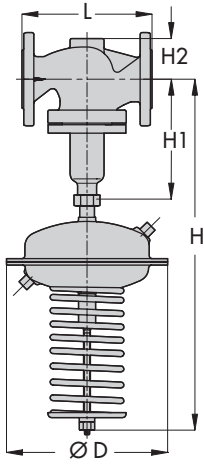

Type 42-24 · Type 2422 Valve balanced by a bellows with Type 2424 Actuator

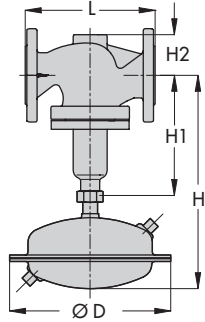

Type 42-28 · Type 2422 Valve balanced by a bellows with Type 2428 Actuator

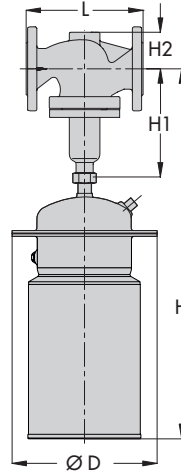

Type 42-24 · Type 2422 Valve balanced by a bellows with Type 2424 Actuator and metal cover

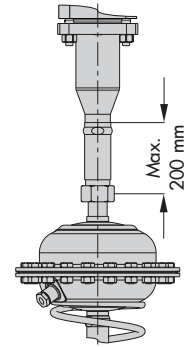

Extension piece

Type 42-24 with two diaphragms: Add approx. 55 mm to the total height H.

Table 4: Dimensions and weights for Type 42-24 and Type 42-28 · Balanced by a bellows

Nominal size	DN	15	20	25	32	40	50	65	80	100	125	150	200	250	
Length L		130	150	160	180	200	230	290	310	350	400	480	600	730	
Height H1		225							300	355	460	590	730		
Height H2	Forged steel	53	-	70	-	92	98								
	Cast steel	44			72			100	120	145	175	235	260		
Type 42-28 Differential Pressure Regulator															
Set points		Type 2428 Actuator													
0.2 bar	Height H ^{5) 6) 7)}	390							465	520					
0.3 bar	Actuator	ØD = 225 mm · A = 160 cm ² 2)							ØD = 285 mm · A = 320 cm ²						
0.4 bar	Weight ³⁾ in kg	11.5	12	13	19.5	20	22.5	38	43	57					
0.5 bar															
Type 42-24 Differential Pressure Regulator															
Set points		Type 2424 Actuator													
0.05 to 0.25 bar	Height H ^{5) 6) 7)}	610							685	740	990	1120	1260		
	Actuator	ØD = 285 mm · A = 320 cm ² 1)							ØD = 390 mm · A = 640 cm ²						
	Weight ³⁾ in kg	21	21.5	22.5	29	29.5	32	46	51	65	135	185	425	485	
0.1 to 0.6 bar	Height H ^{5) 6) 7)}	625							685	740	990	1120	1260		
	Actuator	ØD = 225 mm · A = 160 cm ² 2)							ØD = 285 mm · A = 320 cm ² 1)		ØD = 390 mm · A = 640 cm ²				
	Weight ³⁾ in kg	16	16.5	17.5	24	24.5	27	46	51	65	135	185	425	485	
0.2 to 1 bar	Height H ^{5) 6) 7)}	610							685	740	990	1120	1260		
	Actuator	ØD = 225 mm · A = 160 cm ² 2)							ØD = 390 mm · A = 640 cm ²						
	Weight ³⁾ in kg	16	16.5	17.5	24	24.5	27	42	47	61	135	185	425	485	
0.5 to 1.5 bar	Height H ^{5) 6) 7)}	610							685	740	910	1040	1180		
	Actuator	ØD = 225 mm · A = 160 cm ² 2)							ØD = 285 mm · A = 320 cm ²						
	Weight ³⁾ in kg	16	16.5	17.5	24	24.5	27	42	47	61	125	175	415	475	
1 to 2.5 bar	Height H ^{5) 6) 7)}	610							685	740	910	1040	1180		
	Actuator	ØD = 225 mm · A = 160 cm ²													
	Weight ³⁾ in kg	16	16.5	17.5	24	24.5	27	42	47	61	125	175	415	475	
2 to 5 bar	Height H ^{5) 6) 7)}	590 · (710) ⁸⁾							665 · (785) ⁸⁾	720 · (840) ⁸⁾	825 · (945) ⁸⁾	955 · (1075) ⁸⁾	1095 · (1215) ⁸⁾		
	Actuator	ØD = 170 mm · A = 80 cm ² · ØD = 225 mm · A = 160 cm ² 8)													
	Weight ³⁾ in kg	16	16.5	17.5	24	24.5	27	42	47	61	102	170	410	470	
4.5 to 10 bar ⁴⁾	Height H ^{5) 6) 7)}	710							785	840	945	1075	1215		
	Actuator	ØD = 170 mm · A = 80 cm ²													
	Weight ³⁾ in kg	16	16.5	17.5	24	24.5	27	42	47	61	102	170	410	470	

¹⁾ Optionally with 640 cm² actuator

²⁾ Optionally with 320 cm² actuator

³⁾ The weight applies to the version with the material specifications EN-GJL-250. Add +10 % for all other materials.

⁴⁾ DN 125 to 250: 4.5 to 10 bar on request

⁵⁾ Actuators with metal cover H +135 mm

⁶⁾ The height H increases to 200 mm at the maximum, depending on the extension piece used.

⁷⁾ Minimum clearance required to remove the actuator: +100 mm

⁸⁾ Special version A = 160 cm² without internal excess pressure limiter; with internal excess pressure limiter: H -50 mm

Dimensional drawing of Type 42-24 and Type 42-28 balanced by a diaphragm · Dimensions and weights (see Table 5)

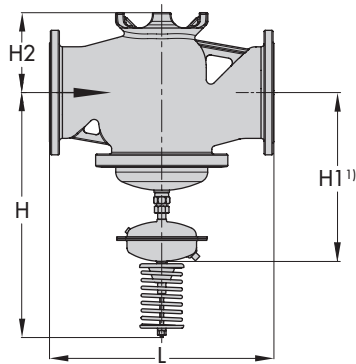

Type 2422 Valve balanced by a diaphragm with Type 2424 Actuator

Dimensional drawing of actuator with two diaphragms

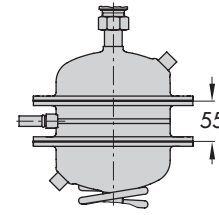

Type 42-24 with two diaphragms: Add approx. 55 mm to the total height H.

Table 5: Dimensions and weights for Type 42-24 and Type 42-28 · Balanced by a diaphragm
Dimensions in mm · Weights in kg

Nominal size DN	65	80	100	125	150	200	250	
Length L	290	310	350	400	480	600	730	
Height H2	98		118	145	175	260		
Type 42-28 Differential Pressure Regulator								
Set points		Type 2428 Actuator						
0.2 bar	Height H ¹⁾	355	375	-				
0.3 bar	Actuator	ØD = 285 mm · A = 320 cm ²						
0.4 bar		-						
0.5 bar	Weight [kg]	38	43	51	-			
Type 42-24 Differential Pressure Regulator								
Set points		Type 2424 Actuator						
0.05 to 0.25 bar	Height H ^{3) 4)}	720	740	815	840	910		
	Actuator	ØD = 390 mm · A = 640 cm ²						
	Weight [kg]	42	47	55	75	95	250	270
0.1 to 0.6 bar	Height H ^{3) 4)}	575	595	815	840	910		
	Actuator	ØD = 285 mm · A = 320 cm ^{2 1)}			ØD = 390 mm · A = 640 cm ²			
	Weight [kg]	42	47	55	75	95	250	270
0.2 to 1 bar	Height H ^{3) 4)}	575	595	735	760	830		
	Actuator	ØD = 225 mm · A = 160 cm ^{2 2)}			ØD = 285 mm · A = 320 cm ^{2 1)}			
	Weight [kg]	42	47	55	75	95	250	270
0.5 to 1.5 bar	Height H ^{3) 4)}	575	575	595	735	760	830	
	Actuator	ØD = 225 mm · A = 160 cm ^{2 2)}			ØD = 285 mm · A = 320 cm ^{2 1)}			
	Weight [kg]	42	47	55	75	95	250	270
1 to 2.5 bar	Height H ^{3) 4)}	575	590	735	760	830		
	Actuator	ØD = 225 mm · A = 160 cm ^{2 2)}						
	Weight [kg]	42	47	55	75	95	250	270
2 to 5 bar	Height H ^{3) 4)}	575	595	735	760	830		
	Actuator	ØD = 225 mm · A = 160 cm ²						
	Weight [kg]	42	47	55	75	95	250	270

¹⁾ Optionally with 640 cm² actuator

²⁾ Optionally with 320 cm² actuator

³⁾ Actuators with metal cover H +135 mm

⁴⁾ Minimum clearance required to remove the actuator: +100 mm

