



Application

Digital controller to automate industrial and process plants for general and more complex control tasks.

The TROVIS 6495-2 Industrial Controller is suitable for control of continuous, on/off or pulsing final control elements (pneumatic actuators with i/p positioners, additional electric actuators, electric heating systems, refrigerating machines etc.)

Special features

- Simple menu structure with plain text display
- 4 analog inputs with filter, root extraction, function generation and measuring range monitoring
- 4 digital inputs for set point switchover, constant output value, reversal of operating action, output tracking (DDC backup), ramps etc
- 3 analog outputs
- 4 relay outputs for two on/off or three-step outputs or four limit alarms
- 2 transistor outputs for fault alarms
- 1 transistor output for fault alarms
- Optional RS-232/USB and RS-485/USB interface boards for SSP and Modbus RTU
- Degree of protection (front) IP 65
- Plug-on screw terminals
- Fixed set point control, one or two channels, internal/external switchover
- Follow-up control, one or two channels, internal/external switchover
- Ratio control
- Cascade control, consisting of master and slave controller
- Limiting or override control
- Mixing control
- Linking of input variables (addition, subtraction, multiplication, division, mean value, minimum and maximum selection) for feedforward control or control with 1 to 4 input variables (multi-component control)
- Operation with up to four internal set points and one ex-



Fig. 1: TROVIS 6495-2 Industrial Controller

- ternal set point, either analog or via interface (SPC mode)
- Set point ramp and output ramp
- Split-range operation
- Control mode selection P/PI or PD/PID
- KP and TN adapted using the controlled variable, reference variable, manipulated variable or error signal
- Adjustable limitation of integral-action component
- Operating point preset by set point or digital input
- Control signal limitation (fixed or floating according to an input variable)
- Operation with code number or key locking by a digital input

Design and principle of operation

The TROVIS 6495-2 Industrial Controller has two independently working controllers with shared input and output sections.

By setting the functions and parameters, the controller can be adapted to a control task quickly. Preset basic configurations for each control type minimize setup work for standard applications. The controller can be set up using the keys on the housing or with the optional TROVIS-VIEW software without requiring any additional accessories.

The controller settings are saved in a non-volatile memory, even when the power supply fails. The two internal controllers can be operated directly without switching. The plain-text display in English, German and French facilitates configuration and parameterization.

Control modes

- Fixed set point control, one or two channels, internal/external switchover
- Follow-up control, one or two channels, internal/external switchover
- Ratio control (mixing control)
- Cascade control, consisting of master and slave controller
- Limiting or override control

Control

- Linking of input variables (addition, subtraction, multiplication, division, mean value, minimum and maximum selection) for feedforward control or control with one to four input variables (multi-component control)
- Operation with up to four internal set points and one external set point, either analog or via interface (SPC mode)
- Set point ramp and output ramp
- Split-range operation
- Control mode selection P/PI or PD/PID
- KP and TN adapted using the controlled variable, reference variable, manipulated variable or error signal
- Adjustable limitation of integral-action component
- Operating point preset by set point or digital input
- Control signal limitation (fixed or floating according to an input variable)
- Operation with code number or key locking by a digital input

Inputs

- 4 analog inputs (AI1 to AI4)

DIP switches at the side of the housing to select current or resistance inputs. The signal type is set depending on the configuration:

- 0/4 to 20 mA
- 0/2 to 10 V
- Pt 100 or Pt 1000 resistance thermometer
- Filter, root extraction, function generation and measuring range monitoring
- Input 2 additionally for potentiometers

- 4 digital inputs (DI1 to DI4)

The digital inputs are controlled either by a 24 V DC voltage signal or by the transmitter supply using a floating contact. The digital outputs can only be controlled in groups, with DI1 and DI2 being the first group and DI3 and DI4 being the second group.

Example: internal supply for digital inputs DI1 and DI2 and external supply for digital inputs DI3 and DI4.

- Set point switchover, constant output value, reversal of operating action, output tracking (DDC backup), ramps etc

The following functions that have been defined over the C Controller, O Output and A General settings menus can be assigned to a digital input (see the 'Start-up and configuration' section):

- Invert digital input
- Switchover between internal set points
- Switchover to external set point
- Opening/closing cascade
- Incremental/decremental set point change
- Set point increase/decrease by constant
- Start set point ramp
- Hold set point ramp
- Invert error signal
- Control mode selection P(D)/PI(D)
- Activate operating point for P/PD controller
- Manual/automatic switchover
- Hold output
- Activate output tracking
- Increase/decrease actual value
- Activate constant output value
- Start output ramp
- Limit output rate
- Lock control keys

Outputs

- 3 analog outputs (AO1 to AO3)

The signal type is set depending on the configuration.

- 0/4 to 20 mA
- 0/2 to 10 V

The outputs AO1 to AO3 can optionally be used for other signals as well.

- 7 digital outputs (4 relay outputs and 3 transistor outputs)

The relay outputs can be used as follows:

- SO1 and SO2 as on/off or three-step output
- DO1 to DO4 as limit output
- DO5 and DO6 (transistor output) for status messages
- DO7 (transistor output) for fault alarms

- 4 relay outputs

for two on/off or three-step outputs or four limit alarms

- 2 transistor outputs

for status messages

- **1 transistor output**
for fault alarms
- **1 supply output**
The supply output can be used to supply a voltage for up to 4 two-wire transmitters and 4 digital inputs (21 V DC, max. 90 mA).

Infrared interface

Data are transmitted between the controller and the TROVIS-VIEW software over an infrared interface, by default integrated into the controller and an infrared adapter (order no. 8864-0900) connected to a computer (see the Mounting and Operating Instructions EB 6495-2).

Communication interface

Optionally, the controller can be equipped with one of the following interface boards. The boards can also be retrofitted.

- **RS-232/USB interface board**
 - One RS-232 interface with RJ-12 jack
 - One USB interface with 5-pin mini-B port

The RS-232 data transfer uses an SSP or Modbus RTU protocol. The memory pen-64 can be used with controllers fitted with an RS-232/USB interface board to load data configured in TROVIS-VIEW or transferred from another controller.

- **RS-485/USB interface board**
 - RS-485 interface (4 terminals) and
 - USB interface (5-pin mini-B port)

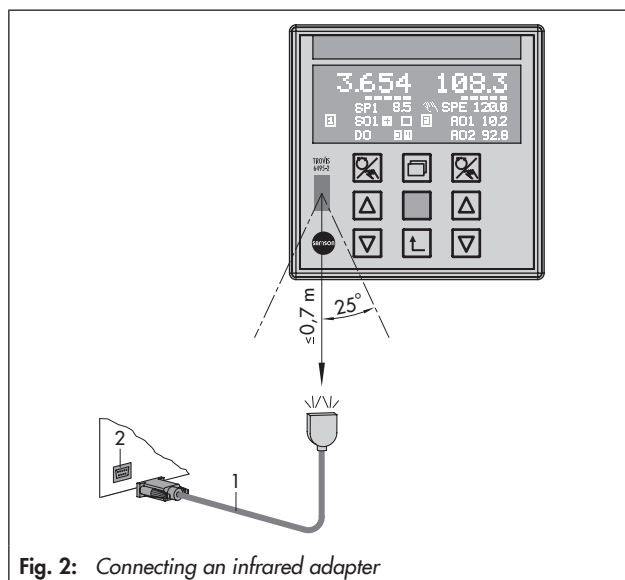

Fig. 2: Connecting an infrared adapter

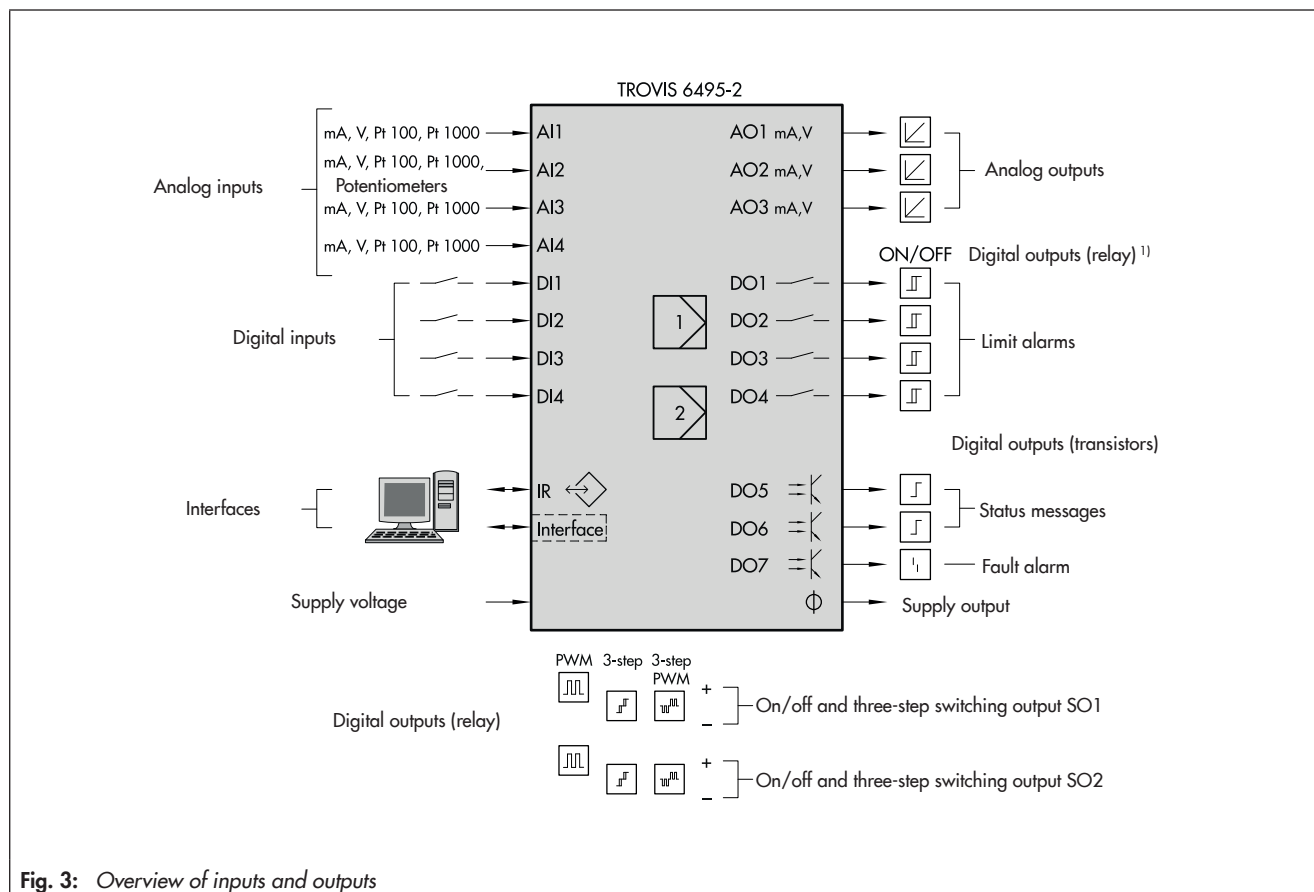
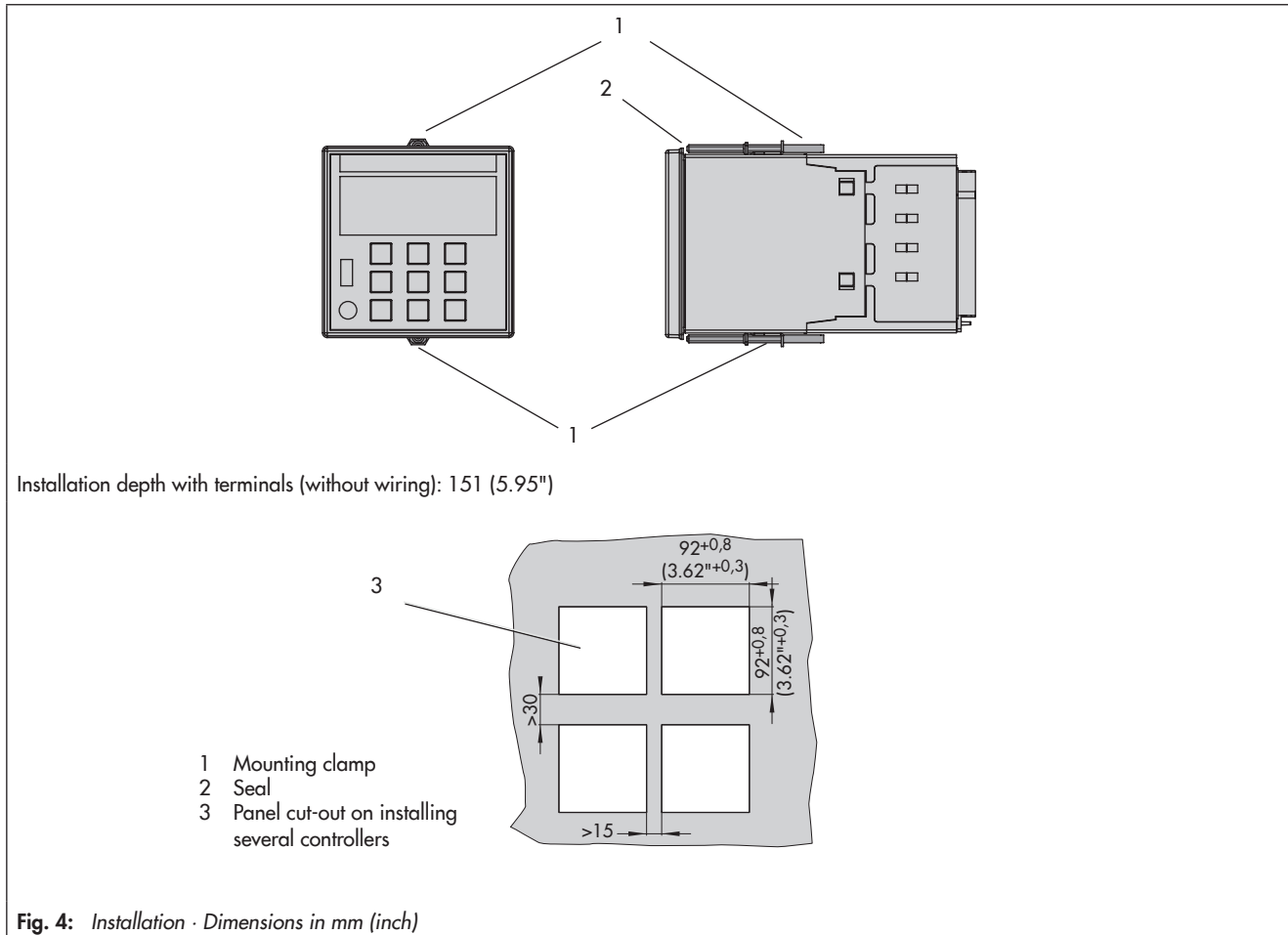

Fig. 3: Overview of inputs and outputs

Mounting

The industrial controller is designed for panel mounting.



Operation

Display and operating controls

The device has nine operating keys, of which three are assigned to each controller channel. Depending on the selected control type, one or two controllers are activated. The readings and controls of the controller [1] are located on the left half of the device and on the right half for controller [2] (or optionally vice versa). The row of keys in the middle is used for both controllers.

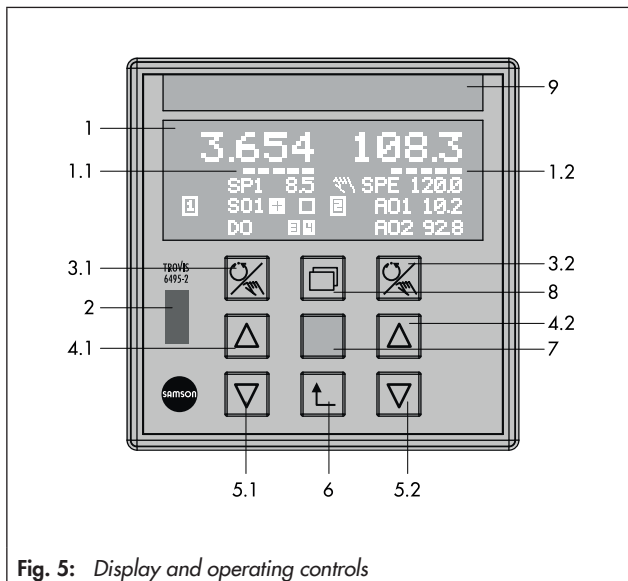

Operating level

After the supply voltage has been switched on, the controller is in operating level.





The readings of the controlled variable, the reference variable and the manipulated variable for each controller as well as a bar graph for error are indicated on the display (1). Depending on the configuration, status alarms of the digital inputs and outputs can be shown. The operating menu allows set points to be switched and control parameters to be changed.

The two rows at the bottom of the display can be assigned as desired. Numerous signals and interim outputs relating to the internal controllers can be selected. For example, the values or a bar graph of two outputs in split-range operation can be displayed.

Configuration and parameterization

The controller is adapted to the selected application in the configuration level. The configuration items are arranged in hierarchical menus. All settings are displayed as plain text.

Table 1: Functions of the operating keys in the levels

Operator key	Operating level	Info menu	Operating menu	Configuration level
 Manual/ automatic	<ul style="list-style-type: none"> Switch between manual and automatic control mode Cascade control: open/close controller cascade 	<ul style="list-style-type: none"> No function 	<ul style="list-style-type: none"> No function 	<ul style="list-style-type: none"> Edit individual items of parameters
 Cursor	<ul style="list-style-type: none"> Automatic mode: Change set point Manual mode: Change output value 	<ul style="list-style-type: none"> Browse through menu items and information 	<ul style="list-style-type: none"> Browse through menu items Change set point and control parameters 	<ul style="list-style-type: none"> Browse through menus, submenus, configuration items and parameters Set configuration items and parameters
 Enter	<ul style="list-style-type: none"> Open main menu (operating menu and configuration level) 	<ul style="list-style-type: none"> Activate menu items 	<ul style="list-style-type: none"> Confirm settings Switch set point 	<ul style="list-style-type: none"> Enter menus, submenus, configuration items and parameters Confirm settings
 Note	<ul style="list-style-type: none"> Enter info menu 	<ul style="list-style-type: none"> No function 	<ul style="list-style-type: none"> No function 	<ul style="list-style-type: none"> No function
 Back	<ul style="list-style-type: none"> Confirm restart after supply voltage failure 	<ul style="list-style-type: none"> Return to the operating level stepwise 	<ul style="list-style-type: none"> Return to the operating level stepwise 	<ul style="list-style-type: none"> Return to the operating level stepwise

Operation using TROVIS-VIEW

Controller settings (see Fig. 6)

Configuration settings and parameters can conveniently be adjusted, documented and transmitted using the optional TROVIS-VIEW software. Working in TROVIS-VIEW is similar to working in Windows® Explorer. TROVIS-VIEW includes a trend viewer for start-up that records the process data. Input and output variables are displayed in a clear structure.

The TROVIS-VIEW software can be delivered on a CD-ROM, if required. For further information on TROVIS-VIEW refer to Data Sheet T 6661.

Data transmission (see Fig. 7)

→ Ordering numbers (see Table 3)

Data can be exchanged between the TROVIS-VIEW software and the controller in various ways:

- Data transmission using the infrared interface (11) and an infrared adapter (14)
- Data transmission using the optional interface board with RS-232 and USB connections: data can be transmitted over a conventional cable connection (either with a USB cable (13) or a connecting cable (15)) or using a memory pen (16).
- To integrate the controller into a communications network, the controller can be fitted with an optional RS-485 interface board. The interface board has a USB connection which can be used to transfer data using TROVIS-VIEW.

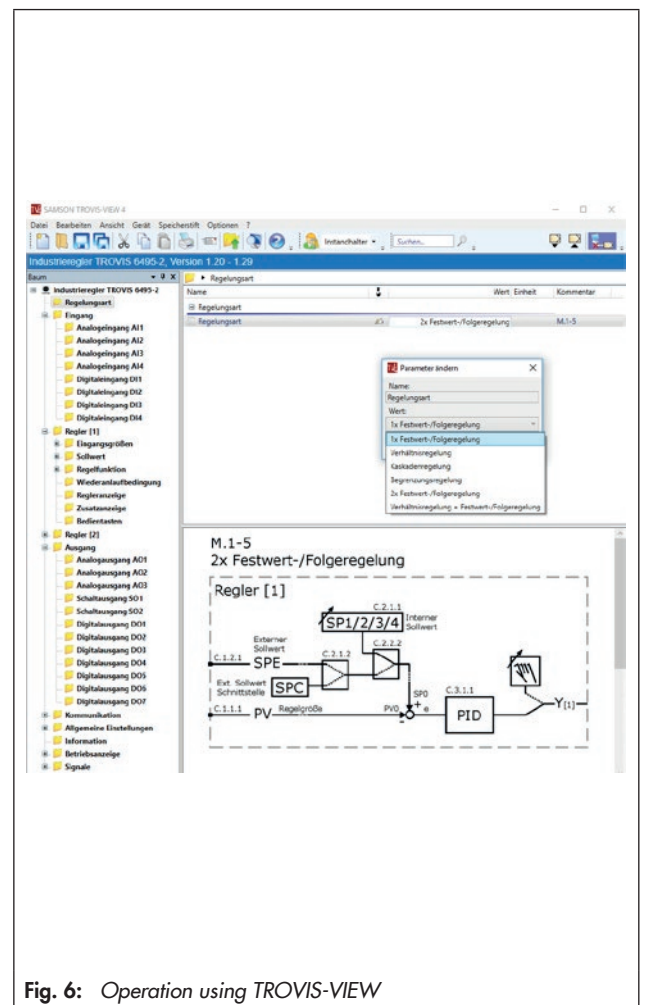

Fig. 6: Operation using TROVIS-VIEW

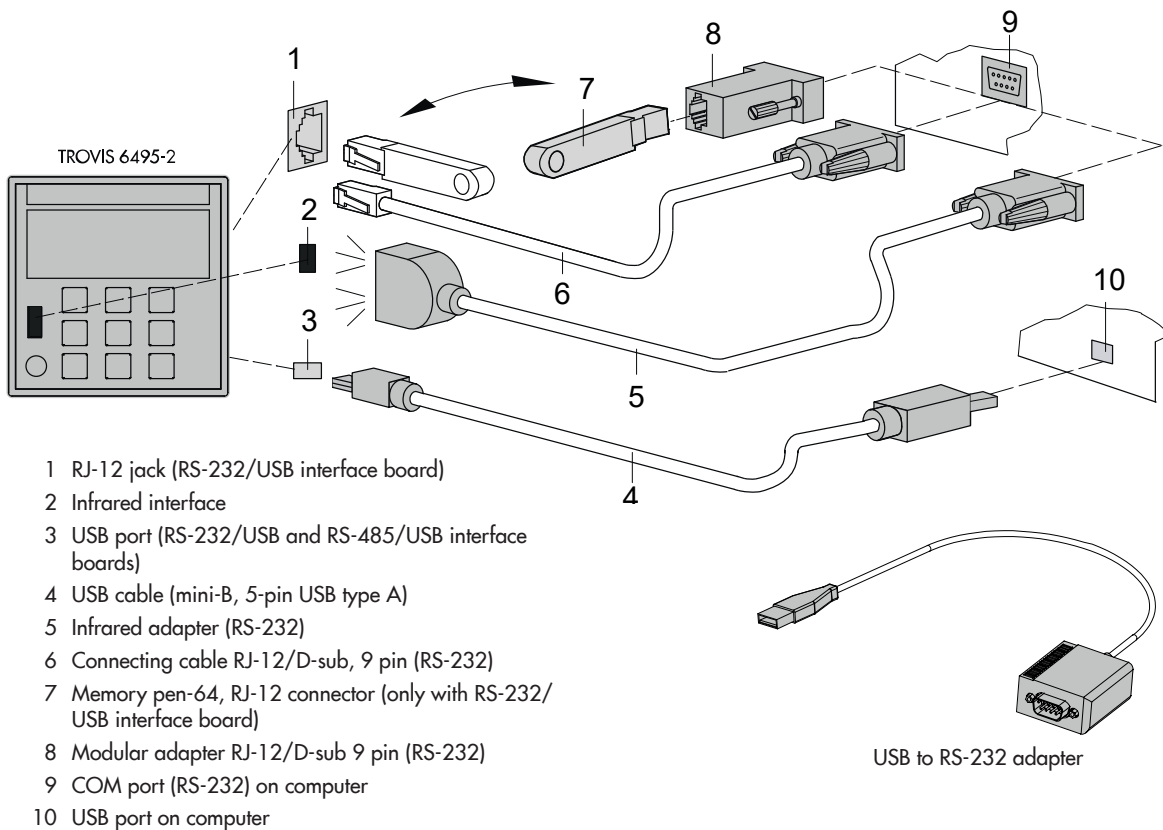

Fig. 7: Data transmission

Electrical connection

	Current	Current Two-wire transmitter	Voltage	Resistance thermometer	Potentiometers
	0/4 ... 20 mA	4 ... 20 mA	0/2 ... 10 V	Pt 100/Pt 1000 Three-wire Two-wire	100/200/500/1000 Ω Three-wire Two-wire
DIP switches					
Supply output ¹⁾	89 + 90 -				
Input AI1	11 - 12 - 13 +		- + - -		
Input AI2	15 - 16 - 17 +		- + - -		
Input AI3	19 - 20 - 21 +		- + - -		
Input AI4	23 - 24 - 25 +		- + - -		

¹⁾ 21 V DC, max. 90 mA

Fig. 8: Electrical connection, terminal strip 1

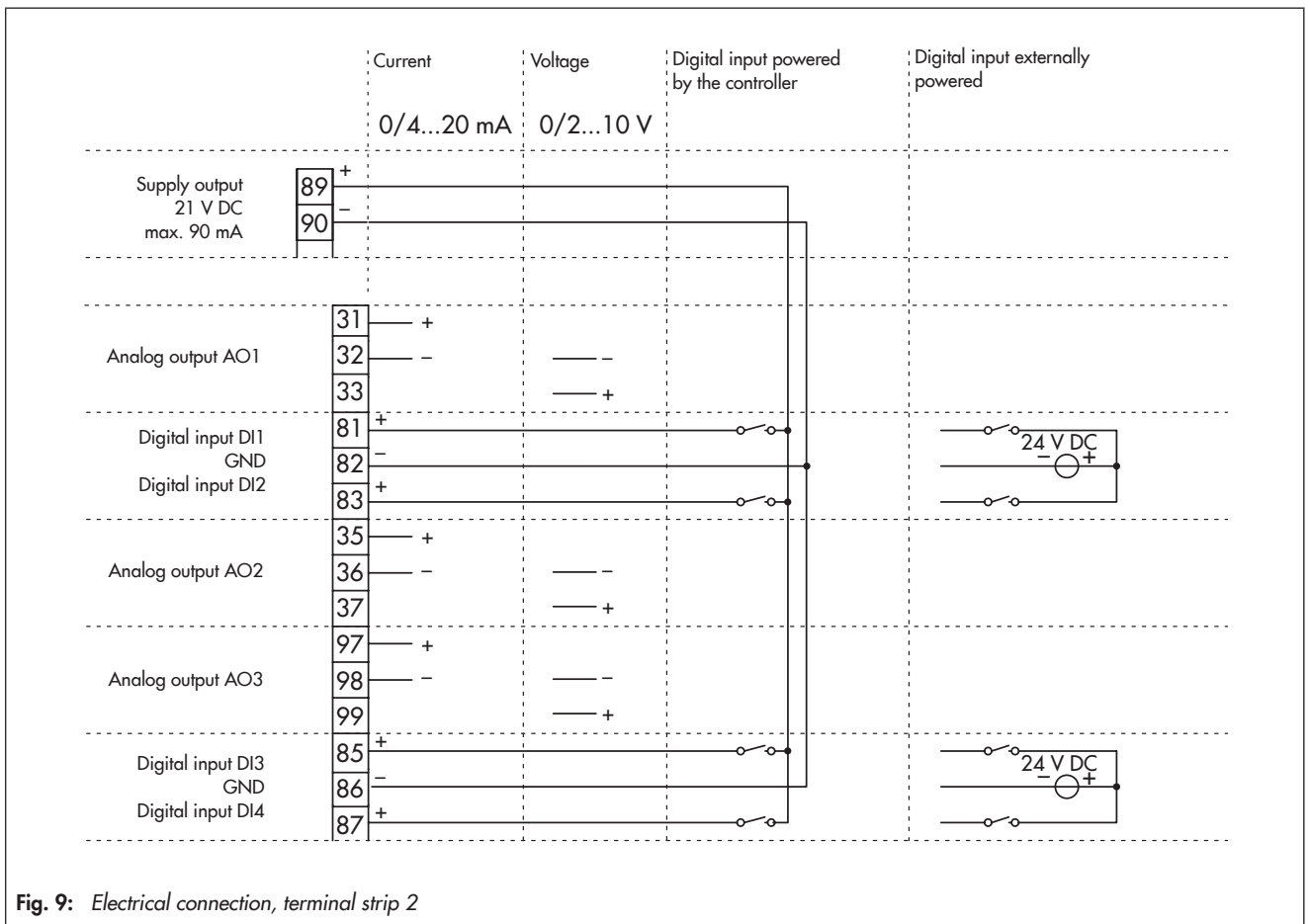

Fig. 9: Electrical connection, terminal strip 2

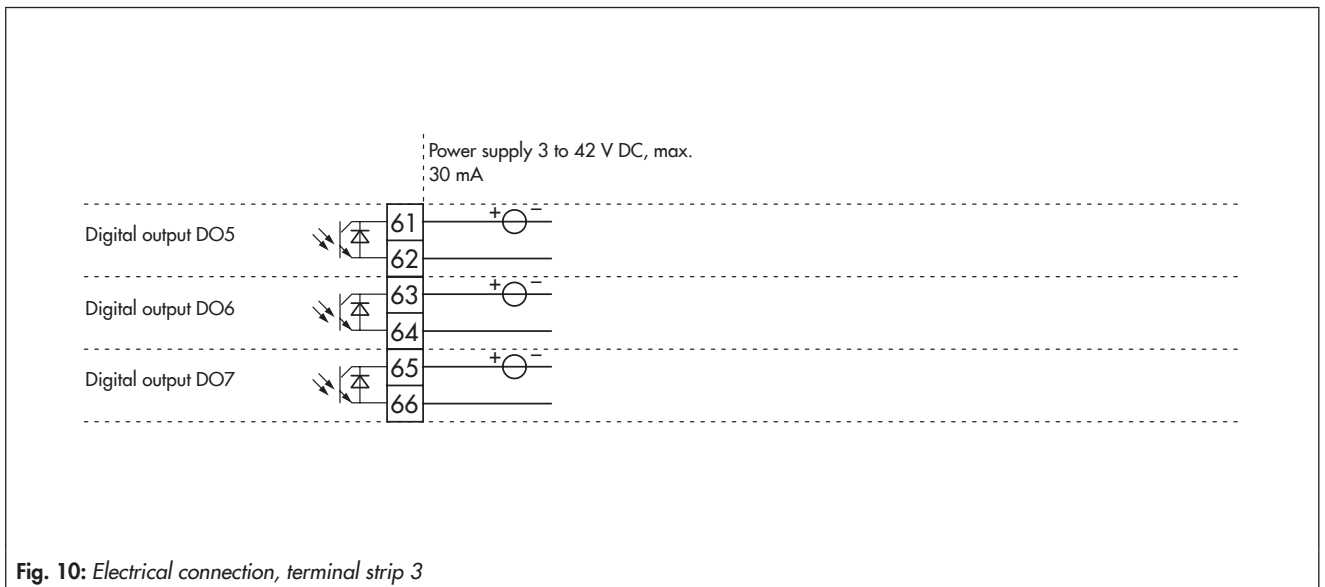

Fig. 10: Electrical connection, terminal strip 3

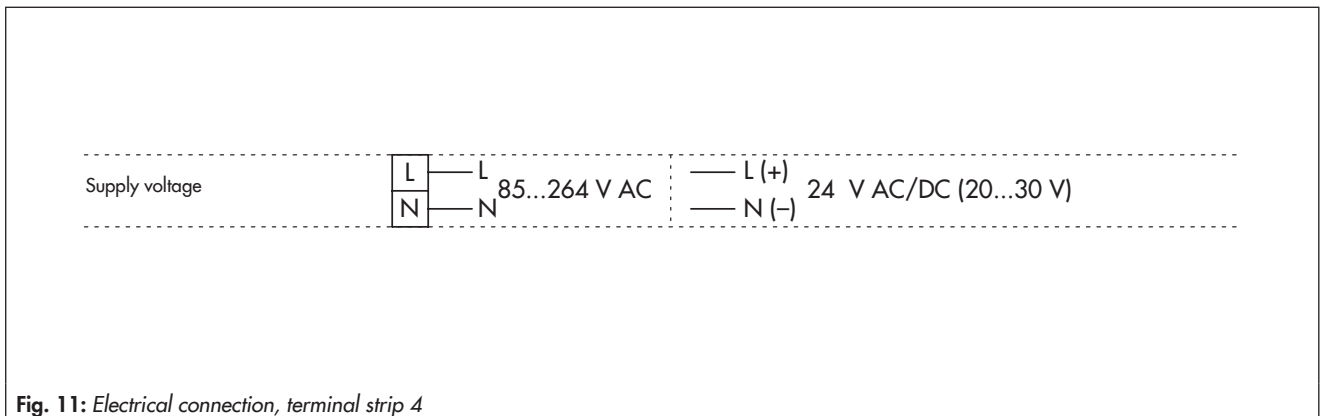

Fig. 11: Electrical connection, terminal strip 4

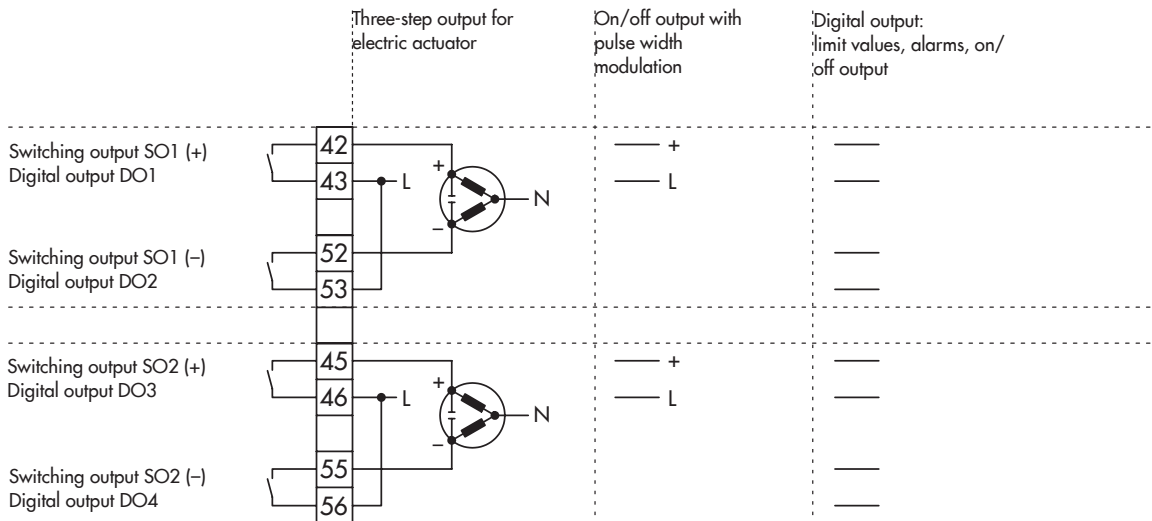

Fig. 12: Electrical connection, terminal strip 5

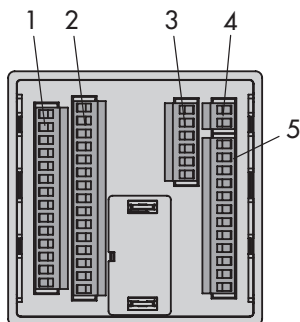

Fig. 13: Terminal blocks 1 to 5 · Back of the controller

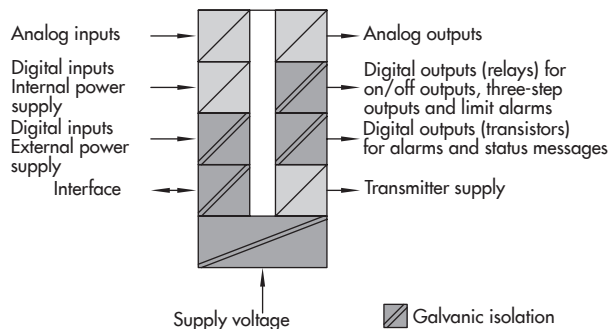
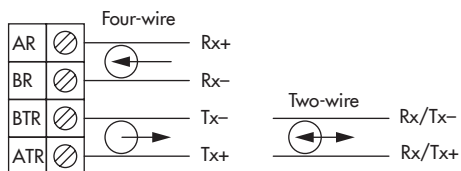
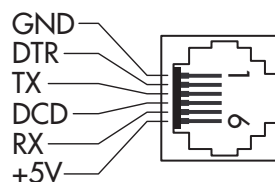

Fig. 14: Galvanic isolation



RS-485 interface



RS-232 interface

Fig. 15: Optional interfaces

Technical data

Table 2: Technical data · TROVIS 6495-2

Inputs		
4 analog inputs		mA, V, Pt 100, Pt 1000, input 2 also for resistance transmitter (potentiometer)
Current or voltage inputs	Version	Differential input
	Nominal signal range	0 to 20 mA, 4 to 20 mA, 0 to 10 V, 2 to 10 V
	Resolution	<0.007 %, relating to nominal signal range
	Permissible signal range	-1 to +22 mA or -0.5 to +11 V
	Input resistance	50 Ω (current); 10 kΩ (voltage)
	Static destruction limit	±50 mA (current); ±30 V (voltage)
Resistance thermometer	For sensor	Pt 100, Pt 1000, according to DIN EN 60751
	Nominal signal range	-50 to +300 °C (-58 to +572 °F)
	Connection	Three-wire connection (resistance of each line <15 Ω), two-wire circuit
Resistance transmitters (potentiometers)	Resolution	<0.02 K (<0.006 % relating to nominal signal range)
	Nominal values	100, 200, 500, 1000 Ω
	Connection	Three-wire connection (resistance of each line <15 Ω)
General specifications	Resolution	<0.006 %
	Measuring error of inputs for zero, span, linearity	<±0.2 % of nominal signal range
	Ambient temperature influence	<±0.1 %/10 K for zero and span (based on 20 °C)
	Input filter	Adjustable
	Function generation	Adjustable using 7 points
	Signal increase/drop	Adjustable
	User calibration	Adjustable
	Transmitter fault alarm	Adjustable, input signal <-5 % or >105 %
Transmitter supply	21 V DC, max. 90 mA, resistant to short circuit	
4 digital inputs		
	Actuation	Floating switching contact or external switching voltage 24 V DC, 3 mA; sets of two digital inputs are galvanically connected on one side Signal state OFF: 0 to 10 V Signal state ON: 17 to 31 V Signal inversion adjustable
Outputs		
3 analog outputs		
	Nominal signal range	0 to 20 mA, 4 to 20 mA, 0 to 10 V, 2 to 10 V
	Max. permissible signal range	0 (2.4) to 22 mA or 0 (1.2) to 11 V
	Load	<750 Ω for current; >3 kΩ for voltage
	Error of outputs	<±0.2 % of nominal signal range for zero, span, linearity
	Ambient temperature influence	<±0.1 %/10 K for zero and span (based on 20 °C)
	Resolution	<0.03 %, relating to nominal signal range
	Static destruction limit	±30 V
7 digital outputs		
Relays	4 relays with floating closing contact (NO), can be inverted	
	Permissible contact load	264 V AC, 1 A AC, cos φ = 1 or 250 V DC, 0.1 A DC
	Spark suppression	Connected in series C = 2.2 nF and varistor 300 V AC, in parallel to each relay contact
Transistor outputs	3 electrically isolated transistor outputs	
	External supply	3 to 42 V DC, max. 30 mA

Interfaces		
Infrared interface	Transmission protocol	SAMSON-specific protocol (SSP)
	Data that can be transmitted	Controller settings, process variables, operating status
	Transmission rate	9600 bit/s
	Angle of reflected beam	50°
	Distance between infrared adapter and controller	≤70 cm
RS-232/USB (accessories)	RS-232 with electrical insulation, USB (slave)	
	Connection	USB: 5-pin mini-B
		RS-232: RJ-12
	Transmission protocol	USB: SAMSON-specific protocol (SSP)
RS-232: SSP and Modbus RTU		
Data that can be transmitted	Controller settings, process variables, operating status, fault alarms	
RS-485/USB (accessories)	RS-485 with electrical insulation, USB (slave)	
	Connection	USB: 5-pin mini-B
		RS-485: 4-pin screw terminals
	Transmission protocol	USB: SAMSON-specific protocol (SSP)
		RS-485: SSP and Modbus RTU
	Data that can be transmitted	Controller settings, process variables, operating status, fault alarms
	Transmission rate/format	SSP: 9600 bit/s, 8 Bit, no parity bit, 1 stop bit
		Modbus: 300 to 115200 bit/s, 8 bit, parity bit adjustable, 1 (2) stop bits
	Type of transmission	RS-485: Asynchronous, half duplex, four-wire or two-wire
	Number of connected devices	RS-485: 32 (can be extended when repeater is used)
	Number of addressable stations	Modbus: 246
Cable length	RS-485: <1200 m; max. 4800 m with repeater	
RS-485 bus termination	Active, selectable	
Transmission medium	RS-485: 2 or 4 cores (twisted pair cable, stranded in pairs, with static shield)	
General specifications		
Supply voltage	85 to 264 V AC, 47 to 63 Hz or 24 V AC/DC (20 to 30 V), 47 to 63 Hz	
Power consumption	85 to 264 V AC	Max. 19 VA, external fuse >630 mA (slow)
	20 to 30 V AC/DC	Max. 15 VA, external fuse >1.25 mA (slow)
Perm. temperature range	Ambient	0 to 50 °C
	Storage	-20 to +70 °C
Relative humidity	Max. 95 %, non-condensing	
Degree of protection	IP 65 (front), IP 30 (housing), IP 00 (terminals) according to EN 60529	
Device safety	According to EN 61010-1: Protection class II, overvoltage category II, degree of contamination 2	
Electromagnetic compatibility	Requirements according to EN 61000-6-2, EN 61000-6-3 and EN 61326-1	
Mechanical environmental influences affecting storage, transport and operation	Sinusoidal vibration according to IEC 60068-2-6: 2 to 9 Hz; 3.5 mm amplitude 9 to 200 Hz; 10 m/s ² acceleration 200 to 500 Hz; 15 m/s ² acceleration Random and guidance vibration according to IEC 60068-2-64: 1.0 m ² /s ³ ; 10 to 200 Hz 0.3 m ² /s ³ ; 200 to 2000 Hz Shocks according to IEC 60068-2-27: Acceleration 100 m/s ² ; duration 11 ms	
Electrical connection	Screw terminals 1.5 mm ² (0.5 to 1.5 mm ² wire cross-section)	
Display	Dot matrix display with 132x49 pixels	
Display range	-999 to 9999; start value, end value and decimal separator can be adjusted	
Cycle time	50 ms (firmware version 1.11 and lower: 100 ms)	
Configuration	Functions saved in read-only memory, configuration saved in non-volatile memory	

Control modes	One or two fixed set point/follow-up control One ratio control One cascade control One ratio and fixed set point/follow-up control One override control
Weight	0.5 kg
Conformity	CE · EAC

Dimensions

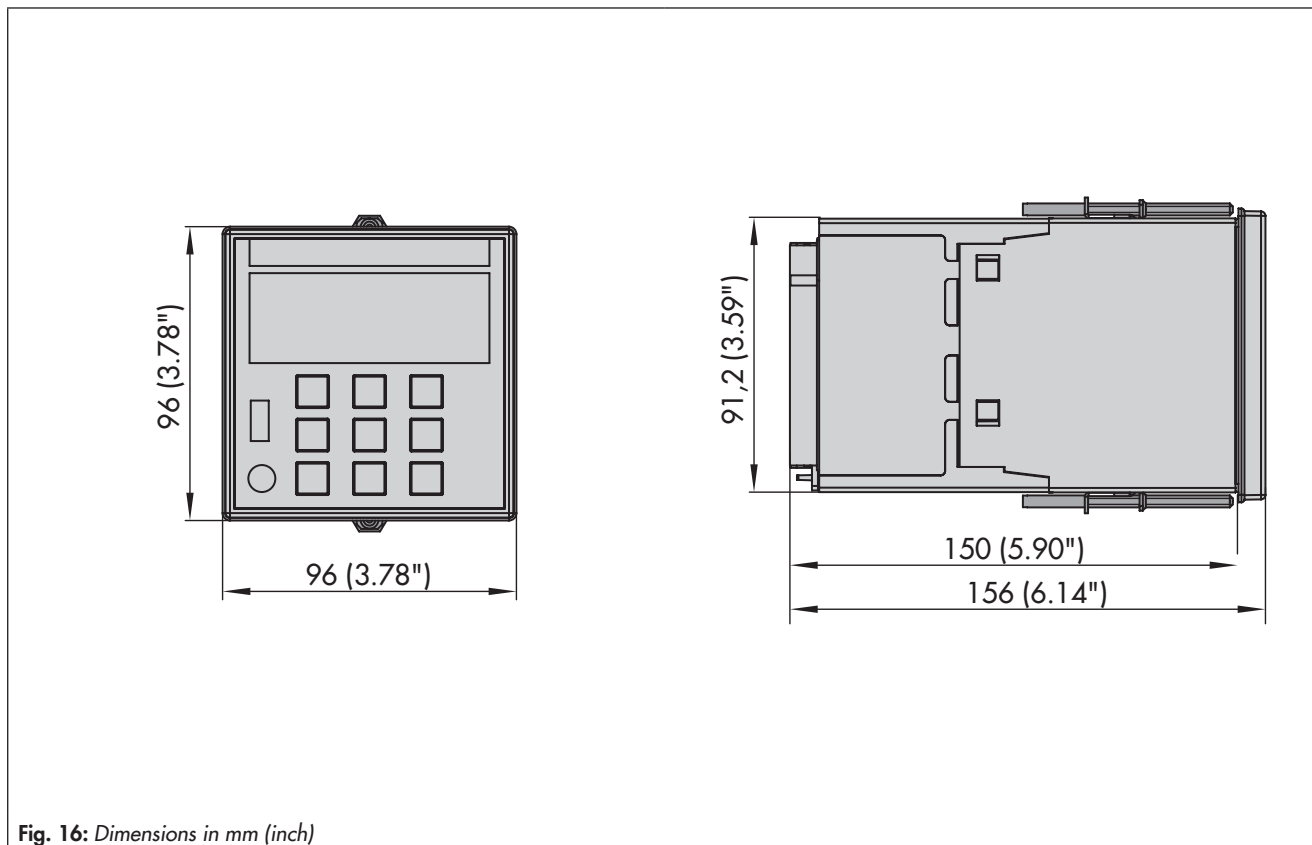

Fig. 16: Dimensions in mm (inch)

Accessories

Table 3: Accessories

Infrared adapter (RS-232)	Order no. 8864-0900
Fixture for infrared adapter	Order no. 1400-9769
USB to RS232 adapter	Order no. 8812-2001
Driver for USB to RS-232 adapter	► www.samsunggroup.com > SERVICE & SUPPORT > Download > TROVIS-VIEW > USB/RS-232 adapter (8812-2001)
TROVIS-VIEW software (free of charge)	► www.samsunggroup.com > SERVICE & SUPPORT > Downloads > TROVIS-VIEW
RS-232/USB interface board	Order no. 1400-9917
RS-485/USB interface board	Order no. 1400-9918
USB cable (2 m) with type A and 5-pin mini-B connectors	Order no. 8801-7301
Connecting cable RJ-12/D-sub, 9 pin (RS-232)	Order no. 1400-7699
Memory pen-64, RJ-12 connector (1170-3163)	Order no. 1400-9753
Modular adapter D-sub 9-pin/RJ-12 for memory pen-64	Order no. 1400-7698
Hardware package consisting of memory pen-64, modular adapter and connecting cable	Order no. 1400-9998

Article code

TROVIS industrial controller	6495-2	x
Supply voltage		
85 to 264 V AC		1
24 V AC/DC		2

Associated Mounting and Operating Instructions

- TROVIS 6495-2 Industrial Controller [▶ EB 6495-2](#)