

DATA SHEET



T 8079 EN

Type 3595 Globe or Angle Valve

ANSI version



Application

Maintenance-friendly cage-guided valve for throttling and on/off service in the oil and gas industry as well as for high-temperature applications in power plant stations

Valve size ¹⁾	NPS ¾ to 32
Pressure rating	Class 150 to 2500
Temperatures	-325 to +1292 °F (-196 to +700 °C)

Special features

- Cage-guided valve (globe or angle-style body) with a pneumatic actuator
- Suitable for liquids and gases
- Plug guided by a cage over the entire travel range
- Minimum distance between plug and cage minimizes vibrations
- Linear or equal percentage characteristic
- Reduced C_v coefficients for valve sizes
- Optionally with flanged body or body with welding ends or welding-neck ends
- Type 3276 or Type 3271 Pneumatic Actuator in various sizes optimized for each valve size
- Diaphragm actuator with central spring or with several springs (multi-spring version)
- Piston actuator optionally double-acting or with fail-safe action (over central spring)
- Simple attachment of valve accessories, e.g. positioners, limit switches or solenoid valves
- Leakage class V also with balanced valve plug over the entire temperature range (in combination with PILOT/STD™ or PILOT/LDB™ trim)

Selectable valve trims

- USS/STD™ or USS/LDB™ ²⁾: single-seated valve with unbalanced plug
- BSS/STD™ or BSS/LDB™ ²⁾: single-seated valve with balanced plug
- CAVLESS™: cage with offset boreholes to prevent cavitation
- PILOT/STD™ or PILOT/LDB™ ²⁾
- MULTICYL™: multi-stage cage
- MULTISTEP™: seat with groove labyrinth



Fig. 1: Type 3595 Valve

¹⁾ Specifications in this data sheet mainly apply to valve sizes up to NPS 16. Specifications for larger valve sizes or other versions are available on request.

²⁾ Noise-reduced version

Forged and cast valve body

- Cast steel
- High-temperature cast steel
- Stainless steel
- Special material (e.g. forged steel, duplex steel, super duplex steel or Inconel®)

Further versions

- DIN valve version (on request)
- Actuator with handwheel (on request)

Principle of operation

The medium flows through the valve in the specified direction. The position of the valve piston determines the cross-sectional area of the cage.

Fail-safe action

Depending on how the compression springs are arranged in the pneumatic actuator, the valve has two fail-safe positions that become effective when the supply air fails.

- **Actuator stem extends (fail-close):** The valve closes when the supply air fails.
- **Actuator stem retracts (fail-open):** The valve opens when the supply air fails.

Valve trims

- USS/STD™ or USS/LDB™ (Fig. 2)
 - USS™ unbalanced plug
 - STD™ standard cage or low-noise version with LDB™ cage
 - Suitable for control and on/off valves
 - Use in flashing service possible
- BSS/STD™ or BSS/LDB™ (Fig. 3)
 - BSS™ balanced plug
 - STD™ standard cage or low-noise version with LDB™ cage
 - Suitable for low to medium pressure drops
 - Tight shut-off
- CAVLESS™ (Fig. 4)
 - BSS™ balanced plug
 - CAVLESS™ cage to minimize cavitation
 - Suitable for applications with liquids in which considerable cavitation occurs, e.g. feedwater supply or condensate systems
 - Use in flashing service possible
- PILOT/STD™ or PILOT/LDB™ (Fig. 5)
 - PILOT™ plug ensures tight shut-off even with low actuator thrust
 - STD™ standard cage or low-noise version with LDB™ cage
 - Suitable for valve sizes NPS 4 and larger
 - Suitable for high temperatures and pressures
- MULTICYL™ (Fig. 6)
 - BSS™ balanced plug
 - MULTICYL™ cage for pressure letdown over several throttling stages
 - Suitable for gases and liquids

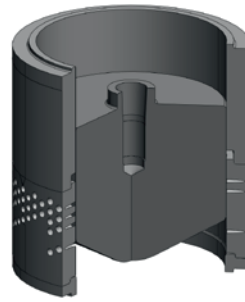

Fig. 2: USS/STD™ and USS/LDB™ valve trims



Fig. 3: BSS/STD™ and BSS/LDB™ valve trims

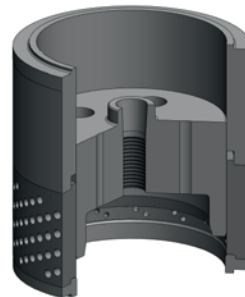

Fig. 4: CAVLESS™ valve trim

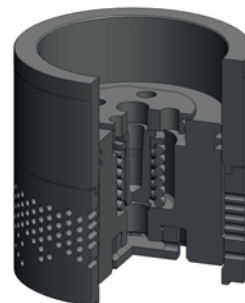

Fig. 5: PILOT/STD™ and PILOT/LDB™ valve trims

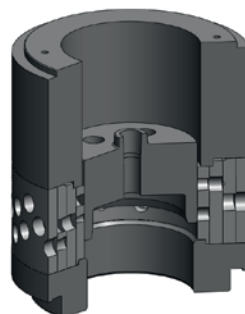

Fig. 6: MULTICYL™ valve trim

- MULTISTEP™ (Fig. 7)
 - Seat with groove labyrinth
 - Designed for low or medium flow rates in combination with high pressure drops (cavitation and flashing)
 - Suitable for valve sizes up to NPS 2
 - Combinable with various plug types
 - Optimizes the control performance at the point where the plug is lifted off the seat

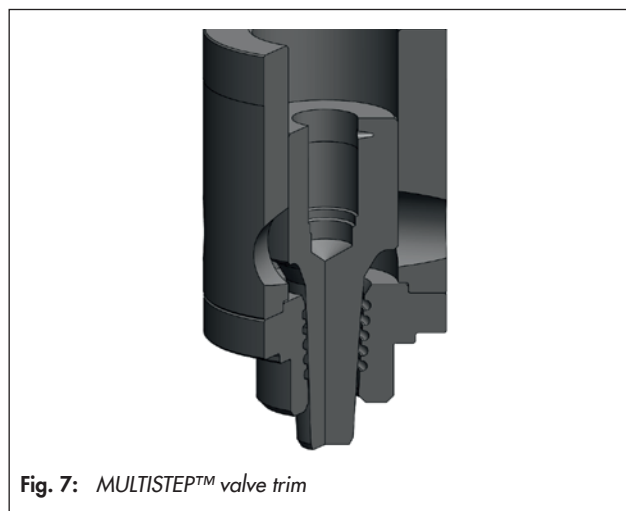

Fig. 7: MULTISTEP™ valve trim

Table 1: Technical data

Type 3595 Globe Valve		Cast body		Forged body	
Valve size		NPS ¾ to 2	NPS 3 to 32	NPS ¾ to 2	NPS 3 to 12
Pressure rating		Class 150 to 2500			
Type of connection	Flanges	•	•	•	•
	Welding ends	•	•	•	•
	Welding-neck ends	•	•	•	•
Characteristic		Equal percentage · Linear · Others on request			
Permissible temperature range					
Valve trim	USS/STD™ · USS/LDB™	–325 to +1292 °F (–196 to +700 °C)			
	BSS/STD™ · BSS/LDB™	Leakage class IV, V and VI: –325 to +482 °F (–196 to +250 °C)			
	CAVLESS™	Leakage class IV, V and VI: –325 to +482 °F (–196 to +250 °C)			
	PILOT/STD™ · PILOT/LDB™	Leakage class V: –4 to +1292 °F (–20 to +700 °C)			
	MULTICYL™	Leakage class IV, V and VI: –325 to +482 °F (–196 to +250 °C)			

Table 2: Materials

Type 3595 Globe Valve		Cast body		Forged body	
Body and valve bonnet	Standard materials	Cast steel or forged steel	A216 WCB	A105	
		High-temperature cast steel or forged steel	A217 WC6 A217 WC9	A182 F11 A182 F22	
		Stainless steel	A351 CF8M	A182 F316	
	Special materials	Duplex steel	A351-CK3MCuN A890 Gr. 4A CD3MN	A182 F44 A182 F51	
		Super duplex steel	A890 Gr. 5A CE3MN A890 Gr. 6A CD3MWCuN	A182 F53 A182 F55	
		Inconel®	A494 CW6MC	B564 N06625	
Valve trim (seat, plug, cage etc.)		AISI 410, AISI 420, AISI 316 and Stellite® or other hard-facing alloy A182 F44, A182 F53, A182 F55, B564 N06625			
Pneumatic actuator with central spring					
Yoke		Cast steel			
Diaphragm case		Sheet steel			
Diaphragm		NBR, EPDM			

Table 3: Flow coefficients for USS/STD™, BSS/STD™ and PILOT/STD™

Valve size NPS	Linear characteristic	Equal-percentage characteristic	Seat Ø		Travel for USS/STD™		Travel for BSS/STD™		Travel for PILOT/STD™	
	C _v coefficient	C _v coefficient	in	mm	in	mm	in	mm	in	mm
2	54	40	1.92	48.88	0.79	20	0.79	20	-	-
	38	28								
3	122	90	2.92	74.28	1.26	32	1.26	32	-	-
	85	63								
4	216	160	3.92	99.68	1.77	45	1.77	45	2.01	51
	150	112								
6	490	360	5.84	148.4	2.52	64	2.52	64	2.83	72
	343	252								
8	864	640	7.94	201.6	3.35	85	3.35	85	3.74	95
	605	450								
10	1350	1000	9.88	251	4.21	107	4.21	107	4.61	117
	945	700								
12	1950	1440	11.88	301.8	5.00	127	5.00	127	5.47	139
	1365	1010								
14	2650	1960	13.84	351.6	5.98	152	5.98	152	6.46	164
	1855	1370								
16	3460	2560	15.84	402.4	6.97	177	6.97	177	7.52	191
	2420	1790								
18	4383	3240	17.84	453.2	7.99	203	7.99	203	8.54	217
	3065	2269								
20	5411	4000	19.84	504	8.86	225	8.86	225	9.49	241
	3784	2801								
22	6547	4840	21.84	554.8	9.88	251	9.88	251	10.51	267
	4579	3389								
24	7792	5760	23.84	605.6	10.79	274	10.79	274	11.50	292
	5449	4034								
26	9144	6760	25.84	656.4	11.69	297	11.69	297	12.40	315
	6395	4734								
28	10605	7840	27.84	707.2	12.60	320	12.60	320	13.39	340
	7417	5490								
30	12174	9000	29.84	758	13.50	343	13.50	343	14.37	365
	8515	6303								
32	13852	10240	31.84	808.8	14.41	366	14.41	366	15.35	390
	9688	7171								

Table 4: Flow coefficients for USS/LDB™, BSS/LDB™ and PILOT/LDB™

Valve size NPS	Linear characteristic	Equal-percentage characteristic	Seat Ø		Travel for USS/LDB™		Travel for BSS/LDB™		Travel for PILOT/LDB™	
	C _v coefficient	C _v coefficient	in	mm	in	mm	in	mm	in	mm
2	49	36	1.92	48.88	0.79	20	0.79	20	-	-
	34	25								
3	110	81	2.92	74.28	1.26	32	1.26	32	-	-
	77	57								
4	195	144	3.92	99.68	1.77	45	1.77	45	2.01	51
	137	100								
6	440	325	5.84	148.4	2.52	64	2.52	64	2.83	72
	310	230								
8	780	580	7.94	201.6	3.35	85	3.35	85	3.74	95
	540	405								
10	1215	900	9.88	251	4.21	107	4.21	107	4.61	117
	850	630								
12	1750	1300	11.88	301.8	5.00	127	5.00	127	5.47	139
	1225	910								

Valve size NPS	Linear characteristic	Equal-percentage characteristic	Seat Ø		Travel for USS/ LDB™		Travel for BSS/ LDB™		Travel for PILOT/ LDB™	
	C _v coefficient	C _v coefficient	in	mm	in	mm	in	mm	in	mm
14	2380	1760	13.84	351.6	5.98	152	5.98	152	6.46	164
	1670	1230								
16	3110	2300	15.84	402.4	6.97	177	6.97	177	7.52	191
	2175	1610								
18	3948	2919	17.84	453.2	7.99	203	7.99	203	8.54	217
	2761	2042								
20	4874	3604	19.84	504	8.86	225	8.86	225	9.49	241
	3408	2522								
22	5897	4360	21.84	554.8	9.88	251	9.88	251	10.51	267
	4124	3051								
24	7018	5189	23.84	605.6	10.79	274	10.79	274	11.50	292
	4908	3631								
26	8237	6090	25.84	656.4	11.69	297	11.69	297	12.40	315
	5760	4261								
28	9553	7063	27.84	707.2	12.60	320	12.60	320	13.39	340
	6681	4942								
30	10966	8108	29.84	758	13.50	343	13.50	343	14.37	365
	7669	5673								
32	12477	9225	31.84	808.8	14.41	366	14.41	366	15.35	390
	8726	6455								

Table 5: Flow coefficients for CAVLESS™

Valve size NPS	Linear characteristic	Equal-percentage characteristic	Seat Ø		Travel	
	C _v coefficient	C _v coefficient	in	mm	in	mm
2	35	25	1.92	48.88	1.02	26
	25	18				
3	78	56	2.92	74.28	1.50	38
	53	38				
4	110	78	3.92	99.68	1.77	45
	74	53				
6	245	175	5.84	148.4	2.52	64
	162	116				
8	490	350	7.94	201.6	2.99	76
	318	227				
10	717	512	9.88	251	4.21	107
	457	326				
12	1265	903	11.88	301.8	5.00	127
	776	554				
14	1754	1253	13.84	351.6	5.98	152
	1084	774				
16	2372	1694	15.84	402.4	6.97	177
	1458	1041				

Table 6: Flow coefficients for MULTICYL™

Valve size NPS	Travel		Characteri- stic ¹⁾	Multi Cyl. 2-stage		Multi Cyl. 3-stage		Multi Cyl. 4-stage		Multi Cyl. 5-stage					
	in	mm		C _v coeffi- cient	Seat Ø	C _v coeffi- cient	Seat Ø	C _v coeffi- cient	Seat Ø	C _v coeffi- cient	Seat Ø				
				in	mm	in	mm	in	mm	in	mm				
2	1.02	26	lin	43	1.61	41	1.73	44	1.26	32	-	-	-		
			eq. %	22										29	19
			mod. eq. %	26										15	9
			mod. lin	35										17	11
			par.	30										23	15
3	1.02	26	lin	43	1.61	41	1.73	44	1.26	32	-	-	-		
			eq. %	22										29	19
			mod. eq. %	26										15	9
			mod. lin	35										17	11
			par.	30										23	15
	1.50	38	lin	87	2.52	64	2.01	51	1.61	41	24	1.26	32		
			eq. %	44										60	38
			mod. eq. %	52										30	19
			mod. lin	70										36	23
			par.	61										49	31
4	1.50	38	lin	87	2.52	64	2.01	51	1.61	41	24	1.26	32		
			eq. %	44										60	38
			mod. eq. %	52										30	19
			mod. lin	70										36	23
			par.	61										49	31
	2.09	53	lin	147	3.50	89	2.99	76	2.64	67	43	2.24	57		
			eq. %	74										104	66
			mod. eq. %	88										52	33
			mod. lin	119										62	40
			par.	103										84	53
6	2.48	63	lin	147	3.50	89	2.99	76	2.64	67	43	2.24	57		
			eq. %	74										104	66
			mod. eq. %	88										52	33
			mod. lin	119										62	40
			par.	103										84	53
	2.95	75	lin	283	4.49	114	4.02	102	3.50	89	83	2.99	76		
			eq. %	142										201	127
			mod. eq. %	170										101	64
			mod. lin	229										121	76
			par.	198										163	103
8	2.95	75	lin	283	4.49	114	4.02	102	3.50	89	83	2.99	76		
			eq. %	142										201	127
			mod. eq. %	170										101	64
			mod. lin	229										121	76
			par.	198										163	103
	3.62	92	lin	465	5.98	152	5.00	127	4.49	114	135	4.02	102		
			eq. %	233										330	210
			mod. eq. %	279										165	105
			mod. lin	377										198	126
			par.	326										267	170
10	3.62	92	lin	465	5.98	152	5.00	127	4.49	114	135	4.02	102		
			eq. %	233										330	210
			mod. eq. %	279										165	105
			mod. lin	377										198	126
			par.	326										267	170
	5.00	127	lin	788	7.99	203	7.01	178	5.98	152	229	5.00	127		
			eq. %	394										559	354
			mod. eq. %	473										280	177
			mod. lin	638										335	212
			par.	552										453	287

Valve size NPS	Travel		Characteri- stic ¹⁾	Multi Cyl. 2-stage		Multi Cyl. 3-stage		Multi Cyl. 4-stage		Multi Cyl. 5-stage					
	in	mm		C _v coeffi- cient	Seat Ø	C _v coeffi- cient	Seat Ø	C _v coeffi- cient	Seat Ø	C _v coeffi- cient	Seat Ø				
				in	mm	in	mm	in	mm	in	mm				
12	5.00	127	lin	788	7.99	203	559	7.01	178	354	5.98	152	229	5.00	127
			eq. %	394			280			177			115		
			mod. eq. %	473			335			212			137		
			mod. lin	638			453			287			185		
			par.	552			391			248			160		
	5.47	139	lin	1050	9.02	229	745	7.99	203	470	7.01	178	305	5.98	152
			eq. %	525			373			235			153		
			mod. eq. %	630			447			282			183		
			mod. lin	851			603			381			247		
			par.	735			522			329			214		
14	5.47	139	lin	1050	9.02	229	745	7.99	203	470	7.01	178	305	5.98	152
			eq. %	525			373			235			153		
			mod. eq. %	630			447			282			183		
			mod. lin	851			603			381			247		
			par.	735			522			329			214		
	6.85	174	lin	1540	10.00	254	1105	9.02	229	692	7.99	203	450	7.01	178
			eq. %	770			503			346			225		
			mod. eq. %	924			603			415			270		
			mod. lin	1247			814			561			365		
			par.	1078			704			484			315		
16	6.85	174	lin	1540	10.00	254	1105	9.02	229	692	7.99	203	450	7.01	178
			eq. %	770			503			346			225		
			mod. eq. %	924			603			415			270		
			mod. lin	1247			814			561			365		
			par.	1078			704			484			315		
	7.28	185	lin	1805	12.01	305	1325	10.00	254	834	9.02	229	543	7.99	203
			eq. %	903			663			417			272		
			mod. eq. %	1083			795			500			326		
			mod. lin	1462			1073			676			440		
			par.	1264			928			584			380		

¹⁾ Characteristic:

- lin Linear
- eq. % Equal percentage
- mod. eq. % Modified equal percentage
- mod. lin Modified linear
- par. Parabolic

Table 7: Weights

Pressure rating	Weight	Valve size (NPS)											
		¾	1	1½	2	3	4	6	8	10	12	14	16
Class 150	kg	On re- quest	17	28	28	55	96	161	242	589	785	1268	1449
Class 300	kg	On re- quest	20	28	30	62	105	188	265	627	801	1345	1552
Class 600	kg	On re- quest	20	28	32	64	115	213	333	806	1072	1463	1830
Class 900	kg	On re- quest	34	53	78	127	176	335	615	892	1585	2096	3461
Class 1500	kg	On re- quest	34	53	78	140	193	485	875	1677	2241	3289	5072
Class 2500	kg	On re- quest	59	108	114	206	311	827	1607	2914	4403	On re- quest	On re- quest

Table 8: Dimensions for Type 3595 Valve

Table 8.1: Body with welding ends or welding-neck ends · NPS ¾ to 4

Dimension	Pressure rating		Valve size NPS					
			¾	1	1½	2	3	4
Length L	Class 150 to 600	in	7.36	7.36	8.74	10.00	12.52	14.49
		mm	187	187	222	254	318	368
	Class 900 and 1500	in	7.64	7.76	9.25	11.50	12.52	14.49
		mm	194	197	235	292	318	368
	Class 2500	in	8.50	8.50	10.24	12.52	15.00	15.98
		mm	216	216	260	318	381	406
Height H2	Class 150 to 600	in	On request	1.69	3.15	2.52	3.15	5.71
		mm	On request	43	80	64	80	145
	Class 900 to 1500	in	On request	2.68	3.35	3.58	4.84	5.94
		mm	On request	68	85	91	123	151
	Class 2500	in	On request	2.8	On request	3.86	On request	6.26
		mm	On request	71	On request	98	On request	159
Height H4	Class 150 to 600	in	7.6	7.6	7.76	8.54	10.91	12.76
		mm	193	193	197	217	277	324
	Class 900 to 1500	in	8.66	8.66	9.49	9.96	12.13	12.32
		mm	220	220	241	253	308	313
	Class 2500	in	10.04	10.04	10.83	11.54	12.87	14.53
		mm	255	255	275	293	327	369
Height H3 with Type 3276 Actuator ¹⁾	Class 150 to 2500	in	3.94	3.94	3.94	3.94	4.92	5.91
		mm	100	100	100	100	125	150
Height H8 ²⁾	Class 150 to 2500	in	On request	On request	On request	On request	On request	On request
		mm	On request	On request	On request	On request	On request	On request

¹⁾ H3 with Type 3271 Actuator, see Table 10

²⁾ Only with Type 3271 Actuator

Table 8.2: Body with welding ends or welding-neck ends · NPS 6 to 16

Dimension	Pressure rating		Valve size NPS					
			6	8	10	12	14	16
Length L	Class 150 to 600	in	20	21.38	29.61	32.24	33.5	43.62
		mm	508	543	752	819	851	1108
	Class 900 and 1500	in	20.00	24.02	30.00	35.98	49.49	55.98
		mm	508	610	762	914	1257	1422
	Class 2500	in	24.02	30.00	40.00	44.02	On request	On request
		mm	610	762	1016	1118	On request	On request
Height H2	Class 150 to 300	in	5.63	6.61	12.4	13.78	16.42	18.5
		mm	143	168	315	350	417	470
	Class 600	in	5.55	6.89	12.8	14.37	16.69	15.75
		mm	141	175	325	365	424	400
	Class 900	in	8.15	10.24	13.5	15.55	17.13	On request
		mm	207	260	343	395	435	On request
	Class 1500	in	8.94	11.26	13.62	15.31	18.11	21.34
		mm	227	286	346	389	460	542
	Class 2500	in	9.45	On request	On request	On request	On request	On request
		mm	240	On request	On request	On request	On request	On request

Dimension	Pressure rating		Valve size NPS					
			6	8	10	12	14	16
Height H4	Class 150 to 300	in	15.35	17.64	21.02	22.87	25.2	27.09
		mm	390	448	534	581	640	688
	Class 600	in	15.24	17.28	22.48	23.62	25.2	26.89
		mm	387	439	571	600	640	683
	Class 900	in	14.53	16.65	24.13	24.25	23.23	26.38
		mm	369	423	613	616	590	670
	Class 1500	in	16.57	17.8	24.13	22.72	25.71	29.53
		mm	421	452	613	577	653	750
	Class 2500	in	17.28	21.26	26.89	30.35	34.72	39.02
		mm	439	540	683	771	882	991
Height H3 with Type 3276 Actuator ¹⁾	Class 150 to 2500	in	7.87	9.84	13.78	15.75	17.72	19.69
		mm	200	250	350	400	450	500
Height H8 ²⁾	Class 150 to 2500	in	On request	On request	On request	On request	On request	On request
		mm	On request	On request	On request	On request	On request	On request

¹⁾ H3 with Type 3271 Actuator, see Table 10

²⁾ Only with Type 3271 Actuator

Table 8.3: Flanged body version · NPS ¾ to 4

Dimension	Pressure rating		Valve size NPS											
			¾		1		1½		2		3		4	
			Flange form											
			RF	RTJ	RF	RTJ	RF	RTJ	RF	RTJ	RF	RTJ	RF	RTJ
Length L	Class 150	in	7.24	-	7.24	-	8.74	-	10.00	-	11.73	-	13.86	-
		mm	184	-	184	-	222	-	254	-	298	-	352	-
	Class 300	in	7.64	-	7.76	-	9.25	-	10.51	-	12.52	-	14.49	-
		mm	194	-	197	-	235	-	267	-	318	-	368	-
	Class 600	in	8.11	8.11	8.27	8.27	9.88	9.88	11.26	11.38	13.27	13.39	15.51	15.63
		mm	206	206	210	210	251	251	286	289	337	340	394	397
	Class 900	in	10.75	10.75	10.75	10.75	13.11	13.11	13.39	13.5	17.36	17.48	18.27	18.39
		mm	273	273	273	273	333	333	340	343	441	444	464	467
	Class 1500	in	10.75	10.75	10.75	10.75	13.11	13.11	13.39	13.5	18.11	18.23	19.02	19.13
		mm	273	273	273	273	333	333	340	343	460	463	483	486
	Class 2500	in	12.13	12.13	12.52	12.52	14.13	14.25	15.75	15.87	19.61	19.84	22.64	23.03
		mm	308	308	318	318	359	362	400	403	498	504	575	585
Height H2	Class 150 to 600	in	On request		1.69		3.15		2.52		3.15		5.71	
		mm	On request		43		80		64		80		145	
	Class 900 to 1500	in	On request		2.68		3.35		3.58		4.84		5.94	
		mm	On request		68		85		91		123		151	
	Class 2500	in	On request		2.8		On request		3.86		On request		6.26	
		mm	On request		71		On request		98		On request		159	
Height H4	Class 150 to 600	in	7.6		7.6		7.76		8.54		10.91		12.76	
		mm	193		193		197		217		277		324	
	Class 900 to 1500	in	8.66		8.66		9.49		9.96		12.13		12.32	
		mm	220		220		241		253		308		313	
	Class 2500	in	10.04		10.04		10.83		11.54		12.87		14.53	
		mm	255		255		275		293		327		369	
Height H3 with Type 3276 Actuator ¹⁾	Class 150 to 2500	in	3.94		3.94		3.94		3.94		4.92		5.91	
		mm	100		100		100		100		125		150	
Height H8 ²⁾	Class 150 to 2500	in	On request		On request		On request		On request		On request		On request	
		mm	On request		On request		On request		On request		On request		On request	

¹⁾ H3 with Type 3271 Actuator, see Table 10

²⁾ Only with Type 3271 Actuator

Table 8.4: Flanged body version · NPS 6 to 16

Dimension	Pressure rating	Valve size (NPS)													
		6		8		10		12		14		16			
		Flange form													
		RF	RTJ	RF	RTJ	RF	RTJ	RF	RTJ	RF	RTJ	RF	RTJ		
Length L	Class 150	in	17.76	–	21.38	–	26.50	–	29.02	–	35.00	–	40.00	–	
		mm	451	–	543	–	673	–	737	–	889	–	1016	–	
	Class 300	in	18.62	–	22.36	–	27.87	–	30.51	–	36.50	–	41.61	–	
		mm	473	–	568	–	708	–	775	–	927	–	1057	–	
	Class 600	in	20.00	20.12	24.02	24.13	29.61	29.72	32.24	32.36	38.27	38.39	43.62	43.74	
		mm	508	511	610	613	752	755	819	822	972	975	1108	1111	
	Class 900	in	23.62	23.74	30.75	30.87	34.02	34.13	40.00	40.12	49.49	49.88	55.98	56.38	
		mm	600	603	781	784	864	867	1016	1019	1257	1267	1422	1432	
	Class 1500	in	27.24	27.48	32.99	33.39	39.02	39.41	44.49	45.12	49.49	50.24	55.98	56.85	
		mm	692	698	838	848	991	1001	1130	1146	1257	1276	1422	1444	
	Class 2500	in	32.24	32.76	40.24	40.87	50.00	50.87	52.01	52.87	On request	On request	On request	On request	
		mm	819	832	1022	1038	1270	1292	1321	1343	On request	On request	On request	On request	
Height H2	Class 150 to 300	in	5.63		6.61		12.4		13.78		16.42		18.5		
		mm	143		168		315		350		417		470		
	Class 600	in	5.55		6.89		12.8		14.37		16.69		15.75		
		mm	141		175		325		365		424		400		
	Class 900	in	8.15		10.24		13.5		15.55		17.13		On request		
		mm	207		260		343		395		435		On request		
	Class 1500	in	8.94		11.26		13.62		15.31		18.11		21.34		
		mm	227		286		346		389		460		542		
	Class 2500	in	9.45		On request		On request		On request		On request		On request		
		mm	240		On request		On request		On request		On request		On request		
	Height H4	Class 150 to 300	in	15.35		17.64		21.02		22.87		25.2		27.09	
			mm	390		448		534		581		640		688	
Class 600		in	15.24		17.28		22.48		23.62		25.2		26.89		
		mm	387		439		571		600		640		683		
Class 900		in	14.53		16.65		24.13		24.25		23.23		26.38		
		mm	369		423		613		616		590		670		
Class 1500		in	16.57		17.8		24.13		22.72		25.71		29.53		
		mm	421		452		613		577		653		750		
Class 2500		in	17.28		21.26		26.89		30.35		34.72		39.02		
		mm	439		540		683		771		882		991		
Height H3 with Type 3276 Actuator ¹⁾		Class 150 to 2500	in	7.87		9.84		13.78		15.75		17.72		19.69	
			mm	200		250		350		400		450		500	
Height H8 ²⁾	Class 150 to 2500	in	On request		On request		On request		On request		On request		On request		
		mm	On request		On request		On request		On request		On request		On request		

¹⁾ H3 with Type 3271 Actuator, see Table 10

²⁾ Only with Type 3271 Actuator

Table 9: Dimensions for Type 3276 Pneumatic Actuator

Dimension			Version (effective diaphragm area)			
			330 (387 cm ²)	350 (645 cm ²)	380 (1032 cm ²)	390 (1032 cm ²)
Height H*	Version with direction of action "actuator stem extends" (FA)	in	17.09	27.17	27.91	34.02
		mm	434	690	709	864
	Version with fail-safe action "actuator stem retracts" (FE)	in	17.6	27.76	31.85	36.65
		mm	447	705	809	931
ØD	in	11.50	15.12	17.99	17.99	
	mm	292	384	457	457	
ØD1	in	9.84	19.69	19.69	19.69	
	mm	250	500	500	500	
Height H9	Version with direction of action "actuator stem extends" (FA)	in	6.65	11.14	11.14	15.83
		mm	169	283	283	402
	Version with fail-safe action "actuator stem retracts" (FE)	in	9.09	15.28	15.94	22.4
		mm	231	388	405	569
Max. travel	in	1.02	2.01	2.99	5.00	
	mm	26	51	76	127	

Table 10: Dimensions for Type 3271 Pneumatic Actuator

Actuator area	cm ²	1000	1400-60	1400-120	1400-250	2800	2 x 2800
Diaphragm ØD	in	18.19	20.87	21.02	21.02	30.32	30.32
	mm	462	530	534	534	770	770
Height H	in	12.32	9.72	18.5	31.5	23.03	42.72
	mm	313	247	470	800	585	1085
Height H3 ¹⁾	in	24.02	24.02	25.59	On request	25.59	25.59
	mm	610	610	650	On request	650	650
Height H7 ²⁾	in	3.54	3.54	5.04	4.33	5.04	5.04
	mm	90	90	128	110	128	128
Thread		M60x1.5			M100x2		
α		G ¾ (¾ NPT)	G ¾ (¾ NPT)	G 1 (1 NPT)	G 1 (1 NPT)	G 1 (1 NPT)	G 1 (1 NPT)

¹⁾ Minimum clearance required to remove the actuator

²⁾ Height of eyebolt according to DIN 580. Height of the swivel hoist may differ.

Dimensional drawings

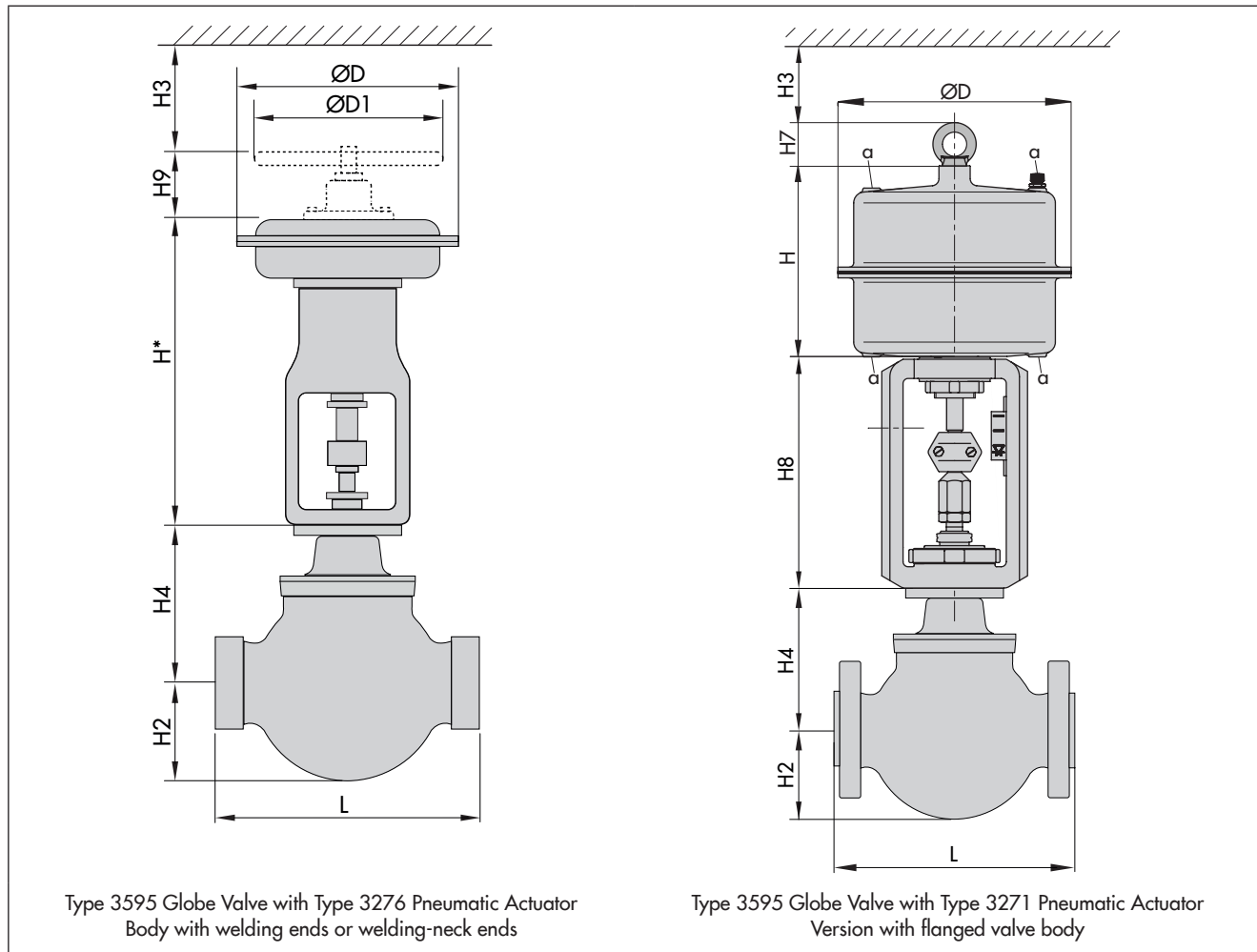

Ordering text

Type ... Valve	3595
Valve size	NPS ...
Pressure rating	Class ...
Body material	Refer to Table 2
Type of connection	Flanges/welding ends/welding-neck ends
Characteristic	Linear or equal percentage
Process medium	Density and temperature (other medium data, if required)
Flow rate	Under normal or operating condition for various cases

Pressure	Upstream pressure p_1 and downstream pressure p_2 or differential pressure Δp each with minimum, normal and maximum flow rate
Valve trim	USS/STD™, USS/LDB™, BSS/STD™, BSS/LDB™, CAVLES™, PILOT/STD™, PILOT/LDB™, MULTICYL™ with/without balanced plug
Actuator	Type 3276 or Type 3271 Pneumatic Actuator
Valve accessories	Positioner, limit switches, solenoid valve or others (see Information Sheet ► T 8350)